

Linear bushings



Changes at a glance

- Intended use and safety information added.
- Lubrication/assembly instructions expanded and now at the beginning of the catalog.
- Short product name with examples for explanation added to facilitate identification for all linear bushings and linear sets in catalog.
- Compact linear sets (R1027 ... / R1029 ...) with normal radial clearance back in stock.
- Load direction factor diagrams for super linear bushings A/B (R0671 ... /R0673 ...) in sizes Ø 16, 20 and 25 updated.
- Super H/SH linear bushings (R0732 .../ R0733 .../ R0730 ... / R0731 ...) and linear sets no longer discontinued and now back in stock. All technical data added.
- Cast iron housings for linear sets (R1065 ... / R1066 ... / R1067 ... / R1068 ...) being gradually replaced with steel housings.
- Cast iron linear sets (R1065 1/R1067 1/R1081 1) with standard linear bushing **without seals** added to the catalog (designed for high-temperature applications).
- Cast iron linear sets (R1073 ... /R1074 ...) with standard linear bushings no longer available. They have been replaced in the catalog with aluminum linear sets (R1071 2.. /R1072 2..) with standard linear bushings.
- Radial linear bushings (R0678 ...) and radial compact sets (R1613 ...) no longer discontinued and back in stock. (Heavy duty version with degrees of freedom in circumferential direction) Matching steel shafts installed with shaft support (R1018 ... /1012 ...) now directly in this section. All technical data added.
- Maximum usable shaft length added to shaft overview. Shaft material updated. Link to shaft configuration tool in Rexroth eShop added. All standard shaft versions now with image numbers. Requests can now be submitted through shaft configuration tool.
- The high aluminum shaft support rail (R1050...) and the version with steel shaft installed (R1011...) are available again up to size Ø 50. All technical data added.



eLINE linear sets, R1027

Super ^H linear bushings, R0730

Linear set, R1071 2

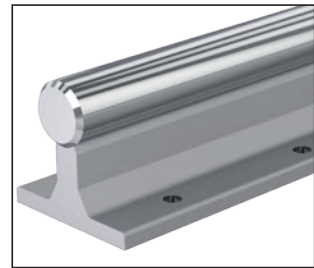

Steel shaft with shaft support rail, R1011



Linear set with steel housing, R1065



Linear set with steel housing, R1067























Radial linear bushings, R0678



Radial compact sets, R1613

Linear bushings

Comparison of linear bushings	9	
Product overview	10	
Important information	12	
Directives and standards	13	
Main dimensions	14	
Load ratings	15	
Life expectancy calculation	16	
Lubrication	21	
Installation	24	
Tolerance tables	26	
eLINE and compact linear bushings	28	
eLINE and compact linear sets	34	
Super linear bushings  and 	38	
Linear sets with super linear bushings  or 	54	
Super linear bushings  and 	74	
Linear sets with super linear bushings  or 	88	
Standard linear bushings	96	
Linear sets with standard linear bushings	120	
Segmental linear bushings	130	
Linear sets with segmental linear bushings	136	
Radial linear bushings	138	
Linear sets with radial linear bushings	146	
Steel shafts with ready-mounted shaft support rails for radial linear bushings	148	
Radial compact sets	152	
Torque-resistant linear bushings	158	
Linear sets with torque-resistant linear bushings	170	
Linear bushings for combined linear and rotary motion	192	
Precision steel shafts and shaft end machining	198	
Steel shafts with shaft support rails ready-mounted, shaft support rails	218	
Shaft support blocks	236	
Further information	241	

Contents

eLINE and compact linear bushings

Normal	R0658		32
Stainless			

eLINE and compact linear sets

Closed, normal or stainless	R1027		34
Adjustable, normal	R1028		34

Tandem	R1029		36
Closed, normal or stainless			

Super linear bushings

Closed	R0670		50
--------	-------	---	----

Open	R0671		50
------	-------	---	----

Super linear bushings

Closed	R0672		36
--------	-------	---	----

Open	R0673		34
------	-------	--	----

Linear sets with super linear bushings or

Closed	R1035		56
Adjustable	R1036		56

Open	R1037		58
Open, adjustable	R1038		58

Side opening	R1071		60
Side opening, adjustable	R1072		60

Linear sets with super linear bushings , tandem

Closed	R1085		62
--------	-------	---	----



Adjustable	R1032		62
------------	-------	---	----

Open	R1087		64
------	-------	---	----

Open, adjustable	R1034		64
------------------	-------	---	----

Flanged	R1083		66
---------	-------	---	----

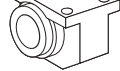
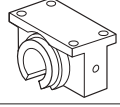
Linear sets with super linear bushings  or 

Closed	R1065		68
Adjustable	R1066		68
Open	R1067		70
Open, adjustable	R1068		70
Flanged	R1081		72

Super linear bushings 

Closed	R0732		84
Open	R0733		84

Super linear bushings 

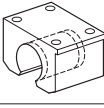

Closed	R0730		86
Open	R0731		86

Linear sets with super linear bushings  or 

Closed	R1701		90
Adjustable	R1702		90
Open	R1703		92
Open, adjustable	R1704		92
Side opening, adjustable	R1706		94

Contents

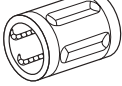
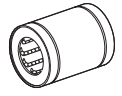
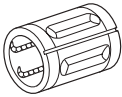
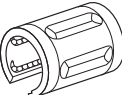
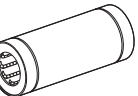
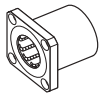
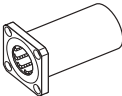
Standard linear bushings

Closed, no wiper seals	R0600		104
Closed, with wiper seals	R0602		104
Closed, no wiper seals, stainless	R0600		106
Closed, wiper seals, stainless	R0602		106
Adjustable, no wiper seals	R0610		108
Adjustable, wiper seals	R0612		108
Open, no wiper seals	R0630		110
Open, wiper seals	R0632		110
Tandem	R0650		112
Wiper seals, normal or stainless			
Flanged	R0740		114
Wiper seals, normal or stainless			
Flanged tandem	R0741		116
Wiper seals, normal or stainless			
Central flanged	R0742		118
Wiper seals, normal or stainless			

Linear sets with standard linear bushings

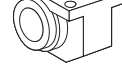
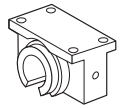
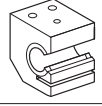
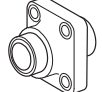
Closed	R1065		122
Adjustable	R1066		122
Open	R1067		124
Open, adjustable	R1068		124
Side opening	R1071		126
Side opening, adjustable	R1072		126
Flanged	R1081		128

Segmental linear bushings

Normal or stainless	R0668		134
---------------------	-------	---	-----

Linear sets with segmental linear bushings

Adjustable, normal or stainless	R1060		136
---------------------------------	-------	---	-----

Radial linear bushings

No wiper seal or fully sealed

R0678

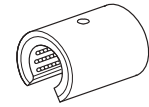

144

Linear sets with radial linear bushings

Open, adjustable

R1076

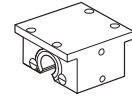

146

Side opening, adjustable

R1078

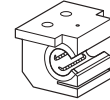

150

Radial compact sets

Open, adjustable

R1613

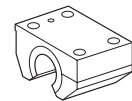

154

Torque-resistant linear bushings

Type 1: One ball guide groove

R0696 0

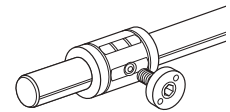

166

Type 2: Two ball guide grooves

R0696 3

166

Torque-resistant compact linear bushings

R0720

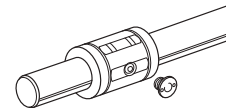

168

Linear sets with torque-resistant linear bushings, aluminum housing

Type 1: One ball guide groove

R1098 2

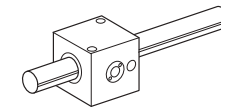

170

Type 2: Two ball guide grooves

R1098 5

170

Tandem

Type 1: One ball guide groove

R1099 2

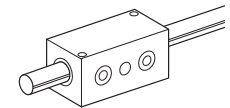

172

Type 2: Two ball guide grooves

R1099 5

172

Linear sets with torque-resistant linear bushings, steel housing

Type 1: One ball guide groove

R1096 2

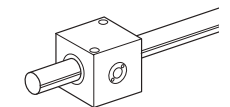

174

Type 2: Two ball guide grooves

R1096 5

174

Tandem

Type 1: One ball guide groove

R1097 2

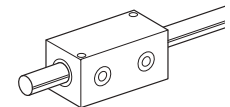

176

Type 2: Two ball guide grooves

R1097 5

176

Linear sets with torque-resistant compact linear bushings

R0721

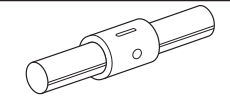

180

Tandem

R0722

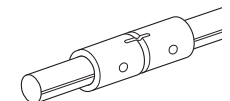

182

Flanged

R0723

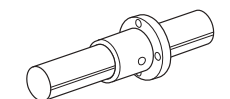

184

Contents

Torque-resistant linear bushings with four ball guide grooves

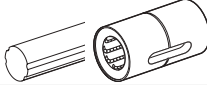
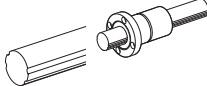
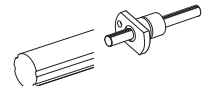
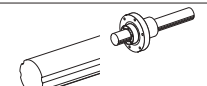
	R0724		186
Flanged	R0725		188
Miniature flanged	R0726		188
Rotational flange	R0727		190

Linear bushings for combined linear and rotary motion

Series 618 deep-groove ball bearing	R0663		194
Series 60 deep-groove ball bearing	R0664		194
Needle bearing, no wiper seals	R0665		196
Needle bearing and wiper seals	R0667		196

Precision steel shafts/shaft end machining

Solid shaft - Heat-treated steel, stainless or hard chrome-plated	R1000		203
Hollow shaft - Heat-treated steel or hard chrome-plated	R1001		203

Steel shafts with shaft support rails ready-mounted, shaft support rails

For open standard and super linear bushings			
Flanged, low profile	R1010		222
For profile systems	R1025		224
Flanged, low profile	R1014		226
Flanged, high profile	R1011		228
Side mounting	R1015		230
Flangeless	R1013		232
Flangeless, with reference edge	R1016		234
For radial linear bushings	R1018		148
	R1052		148
For radial compact sets	R1012		156

Shaft support blocks

Aluminum, compact	R1058		166
Aluminum	R1057		166
Cast iron/steel	R1055		168
Cast iron, flanged	R1056		170

Comparison of linear bushings

Requirements	Linear bushing model							
	Compact/ eLINE	Super A/B	Super H/ SH	Standard	Segmental	Radial	Torque- resistant	Combined linear and rotary motion
Frequency of use	+++	+++	+	++	++	+	+	+
Low cost	+++	++	+	++	+++	+	+	+
Very easy to install	+++	++	+	++	++	+	+	++
Very compact design	+++	+	+	+	+++	-	+	+
Stainless version also available	+++	-	-	+++	+++	-	-	-
High load	+	++	+++	+	+	+++	++	+
Misalignment compensation	-	+++ ¹⁾	+++	-	-	-	-	-
Very smooth travel	++	+++	+	++	++	++	++	++
High temperature > 100 °C	-	-	-	+++	-	-	-	-
Coarse soiling	-	-	-	+++	-	-	-	-
Humid/wet environment	++	-	++	+++	++	-	-	-
Water-based coolant/lubricants	++	-	-	+++	++	-	-	-
Designed for vacuum	-	-	-	+++	-	-	-	-
Torque transmission	-	-	-	-	-	-	+++	-
Combined linear and rotary motion	-	-	-	-	-	-	-	+++

1) Super A only

+++ Very good
++ Good

+ Fair
- Adequate (not recommended)

Technical data		Linear bushing model							
		Compact/ eLINE	Super A/B	Super H/ SH	Standard	Segmental	Radial	Torque- resistant	Combined linear and rotary motion
Dynamic load rating $C_{max}^{1)}$	(N)	5,680	12,060	23,500	21,000	3,870	54,800	9,250 ⁴⁾	21,000
Diameter d	(mm)	8 to 50	10 to 50	20 to 60	3 to 80	12 to 40	30 to 80	12 to 50	5 to 80
Friction coefficient $\mu^{2)}$	(-)	0.001 to 0.004	0.001 to 0.004	0.001 to 0.004	0.001 to 0.0025	0.001 to 0.004	0.001 to 0.002	0.001 to 0.004	0.001 to 0.0025
Speed v_{max}	(m/s)	5	3	5	2.5	3	2	3	2.5
Acceleration a_{max}	(m/s ²)	150	150	150	100	150	50	150	100
Operating temperature	(°C)	-10 to 80 ³⁾							

1) Maximum speed depends on the load rating. ➔ "Technical data" section for each linear bushing

2) No seals. The friction coefficient is lowest under high load. It can also be greater than the indicated value under low loads.

3) Standard linear bushings without seals can also be used above 100 °C.

4) For torque-resistant linear bushings with one or two ball guide grooves; version with four ball guide grooves up to 36,600 N.

Product overview

In this catalog, you will find the right solution for any application from the broad range of linear bushing guides.

The eLINE linear bushing has a compact design and **reduced radial clearance**.

The integrated metal holding ring in this model means it does not require the usual additional axial securing in the mounting hole. The eLINE linear bushing has two integrated wiper seals, and the normal and stainless versions come greased from the factory.



The compact linear bushings are essentially identical to the eLINE linear bushings.





They come with normal radial clearance and optional integrated wiper seals in normal and stainless versions.

The super linear bushing  has built-in misalignment compensation that compensates for an angle misalignment between the housing and shaft of up to 0.5 degrees without reducing load rating due to angular pressure. This misalignment can be caused by shaft deflection due to high load or inaccuracies in the connecting structure. The self-aligning feature ensures that the balls enter the load-bearing zone smoothly and that the load is distributed evenly across the entire row of balls. This is what produces the unmatched smooth travel, robust construction and extra long service life of this linear bushing.

For high loads and extra long guides, the super linear bushings are also available in an open design for use on supported shafts.

The super linear bushing  without misalignment compensation is the solution for applications where only one linear bushing is used per shaft and the linear bushing is not allowed to commute on the shaft.



Compared to the current and proven super linear bushing  , the super linear bushings  and  have more load-bearing steel bearing plates and rows of balls. Very high load ratings  and extra high load ratings  allow movement of very heavy loads with full alignment compensation.

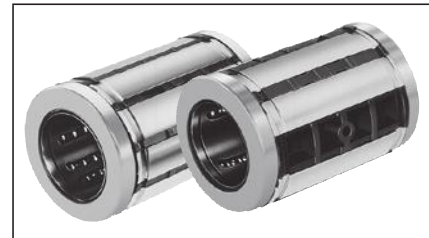

The standard linear bushing is extremely robust thanks to its steel ball retainer and designed for applications with a high level of soiling, such as woodworking. It is available in closed, adjustable and open versions. Standard linear bushings without seals are available for use at very high temperatures. The closed standard linear bushing is also available in stainless steel and is specially designed for applications under vacuum or in the food industry.



With its sturdy plastic housing, the segmental linear bushing is the most inexpensive ready-to-install linear bushing guide. This linear bushing also comes in a stainless version for applications in corrosive conditions or with high demands for cleanliness, such as in food processing, semiconductor manufacturing and medical technology.



The radial linear bushings are high-precision linear bushings for moving extremely heavy loads. Radial ball redirection allows numerous rows of balls and extremely high load ratings.

This series stands out in its extreme rigidity and smooth running, as well as additional degrees of freedom in circumferential direction.

For applications where other linear guides tend to warp due to imprecise substructures.



Torque-resistant linear bushings are full-fledged linear guides with just one shaft. The torque is transmitted through underlying ball circuits.

These torque-resistant linear bearings come with multiple ball guide grooves depending on the degree of the torque being transmitted,



Linear bushings for combined linear and rotary motion come with a deep-groove ball bearing or a needle bearing. They are designed for swiveling movements and moderate speeds.



Linear sets are complete bearing units consisting of a housing with one or two Rexroth linear bushings. Numerous versions are available. Thanks to efficient manufacturing, linear sets offer the user significant cost benefits over in-house designs. The housing is easily oriented during installation to prevent the linear bushings from warping.



Precision steel shafts come in various tolerances, as either solid or hollow shafts made of heat-treated steel, stainless steel, or hard chrome-plated steel. Rexroth offers precision steel shafts cut to your size with chamfering on both ends or machined according to your drawing or description.

Use our shaft configuration tool.

www.boschrexroth.com/shaft-configuration



Steel shafts with shaft support rails ready-mounted, shaft support rails and shaft support blocks in various designs round out the linear bushings.

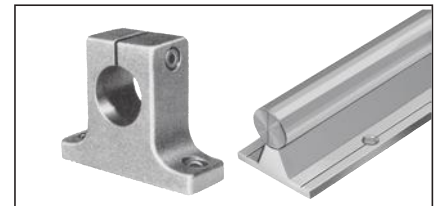

Important information

Intended use

- Linear bushings are linear guides for absorbing all transverse forces and axial torque, and some special models can even absorb rotational torque along all axes. Linear bushing guides are intended only for guiding and positioning in machines.
- The product is intended solely for professional use and not for private use.
- Intended use includes reading and understanding the included documentation, specifically this safety information.

Improper use

Any use other than that described as intended is considered improper and is prohibited. Installing or using unsuitable products in safety-relevant applications can produce unintended operating states that can result in injury and/or property damage.

The product should therefore only be used in safety-relevant applications if such use is expressly specified and permitted in the product documentation.

Bosch Rexroth AG cannot be held liable for damage resulting from improper use.

The user bears all risk resulting from improper use.

Improper use of the product includes:

- The transport of persons

General safety information

- Follow the safety regulations of the country in which the product is used.
- Follow all applicable accident prevention and environmental safety regulations.
- Only use the product when it is in good working order.
- Observe the technical data and environmental conditions specified in the product documentation.
- Do not use the product until it has been determined that the end product (e.g., a machine or system) using the product is in compliance with country-specific provisions, safety regulations and standards of application.
- Do not use Rexroth linear bushings in explosive environments as per Directive 94/9/EC (ATEX).
- Please refrain from modifying or altering Rexroth linear bushings. Only perform the tasks described in the “Quick Start Guide” or “Linear Bushing Assembly Manual”.
- Please refrain from disassembling the product.
- The product will produce a certain level of noise at high travel speeds. Take appropriate steps to protect hearing, if necessary.
- Comply with special safety requirements in certain sectors (e.g., crane construction, theater, food industry technology) set forth in legislation, directives and standards.
- Make sure all bolt connections are state of the art.
- Bolts with a minimum strength class of 8.8 under ISO 4762 must be used for fastening. The maximum tightening torques for this bolt class should also not be exceeded when using stronger bolts.
- The maximum load capacity of a guide is determined not just by the static and dynamic load-bearing capacity of the rolling contacts, but primarily by the bolt connection joining the shaft support rail and housing. DIN ISO 13012-1 and DIN ISO 13012-2 specify the relevant thread diameters and hole spacing.
- **ATTENTION** - Make sure to use all mounting holes in the housing and support shaft rail.

Directives and standards

Rexroth linear bushing guides are designed for reliability and high precision in dynamic, linear applications. The machine tool industry and other sectors must comply with a variety of standards and directives. These requirements differ substantially around the world. This is why familiarizing yourself with regional standards and directives is absolutely essential.

DIN EN ISO 12100

This standard describes machine safety – principles and guidelines, risk assessments and risk reduction. It provides a general overview as well as a guide on the critical development of machines and their intended use.

DIN ISO 13012

Rolling bearings – Accessories for sleeve-type linear ball bearings.

This part of ISO 13012 specifies the boundary dimensions, other relevant dimensions and their tolerances for accessories for sleeve-type linear ball bearings specified in ISO 10285.

This part of ISO 13012 applies to:

Housings, shaft support rails, shaft support blocks and shafts.

Directive 2006/42/EC

The Machinery Directive describes the basic health and safety requirements for designing and manufacturing machinery. The machine manufacturer or authorized representative must ensure that a risk assessment is performed in order to determine the health and safety requirements for the machine. The machine must be designed and built in accordance with this risk assessment.

Directive 2001/95/EC

This directive describes general product safety for all products placed on the market and intended for or will presumably be used by consumers, including products used by consumers as part of a service.

Directive 85/374/EEC

This directive describes liability for faulty products and applies to industrially produced movables regardless of whether or not they have been installed in immovables.

Directive 76/769/EEC

This directive describes the restrictions on the marketing and use of certain dangerous substances and preparations. Substances are chemical elements and compounds thereof that occur naturally or as a result of production. Preparations are mixtures, compounds and solutions consisting of two or more substances.

Main dimensions

Comparison of individual linear bushings

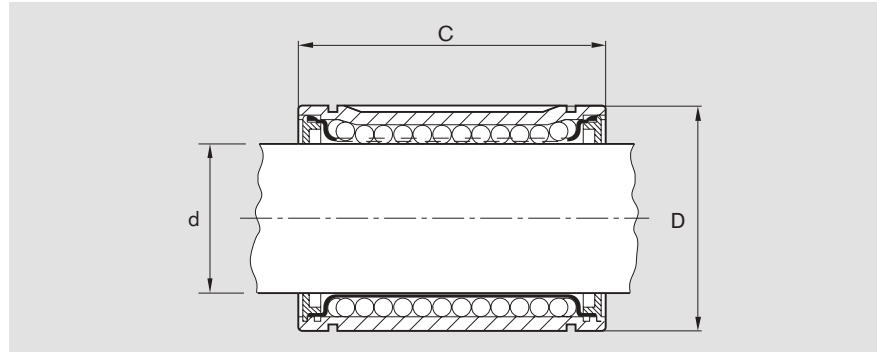

Dimensions (mm)													
Shaft Ø d	eLINE and compact linear bushings		Super linear bushings A and B		Super linear bushings H and S		Standard linear bushings		Segmental linear bushings		Radial linear bushings		
	D	C	D	C	D	C	D	C	D	C	D	C	C
3	-	-	-	-	-	-	7	10	-	-	-	-	-
4	-	-	-	-	-	-	8	12	-	-	-	-	-
5	-	-	-	-	-	-	12	22	-	-	-	-	-
8	15	24	-	-	-	-	16	25	-	-	-	-	-
10	17	26	19	29	-	-	19	29	-	-	-	-	-
12	19	28	22	32	-	-	22	32	20	24	-	-	-
14	21	28	-	-	-	-	-	-	-	-	-	-	-
16	24	30	26	36	-	-	26	36	25	28	-	-	-
20	28	30	32	45	32	45	32	45	30	30	-	-	-
25	35	40	40	58	40	58	40	58	37	37	-	-	-
30	40	50	47	68	47	68	47	68	44	44	60	75	-
40	52	60	62	80	62	80	62	80	56	56	75	100	-
50	62	70	75	100	75	100	75	100	-	-	90	125	-
60	-	-	-	-	90	125	90	125	-	-	110	150	-
80	-	-	-	-	-	-	120	165	-	-	145	200	-

DIN ISO 10285 Linear ball bearings – Metric series

This standard specifies the boundary dimensions, tolerances and terms for linear ball bearings. It divides linear bushings into size groups and tolerance classes.

DIN ISO 13012 Linear ball bearings – Accessories

This standard specifies the boundary dimensions and other useful dimensions of accessories for metric series linear ball bearings.

Accessories include bearing housings, shafts, shaft support blocks and shaft support rails. It is used in conjunction with DIN ISO 10285.

Load ratings

Definition as per DIN ISO 14728

Dynamic load rating C

The radial load of constant magnitude and direction which a linear rolling bearing can theoretically endure for a nominal service life of 10^5 m distance traveled.

Note: The dynamic load rating requires that the stroke of the linear ball bearing is at least three times its overall length.

Some of the dynamic load ratings in the tables are up to 30% above the DIN values. They have been verified in experiments.

Static load rating C_0

The static radial load corresponding to a calculated load of 5,300 MPa at the center point of the contact point under the heaviest load between rolling element and track (shaft).

Note: The permanent overall deformation of rolling element and track corresponds to roughly 0.0001 times the diameter of the rolling element.

Nominal service life

The calculated service life which an individual linear rolling bearing or a group of apparently identical rolling element bearings operating under the same conditions can attain with a 90% probability using contemporary, commonly used materials and manufacturing quality under conventional operating conditions.

Load direction

If load direction and location of the linear bushings are not clearly defined, the minimal values of the load ratings must be used. The maximum load ratings can only be used if the bearings can be installed along the load direction.

The tables show the minimum, maximum or both load ratings for the **closed** and adjustable linear bushings, depending on the type. **Open** linear bushings must be secured. The load rating indicated for the main load direction vertical to the opening applies here.

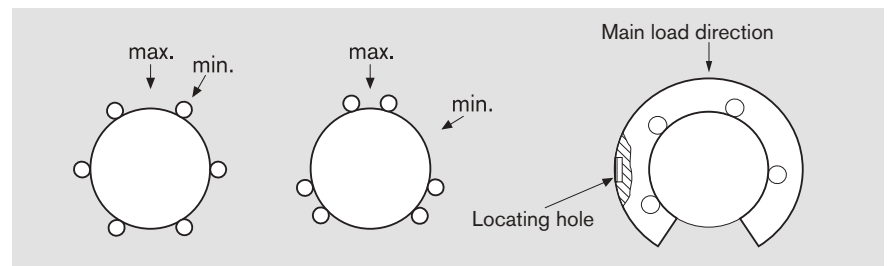

Life expectancy calculation

Nominal service life

$$L = \left(\frac{C}{F_m} \times f_H \times f_t \times f_s \right)^3 \cdot 10^5$$

$$L_{hrs} = \frac{L}{2 \cdot s \times n_s \times 60}$$

- L = Nominal service life (m)
- L_{hrs} = Nominal service life (hrs)
- C = Dynamic load rating (N)
- F_m = Equivalent dynamic load (N)
- f_H = Shaft hardness factor -
- f_t = Temperature factor -
- f_s = Short stroke factor (for segmental, compact, eLINE and super linear bushings only) -
- s = Stroke length (m)
- n_s = Stroke repetition rate (double stroke) (rpm)

Shaft hardness factor

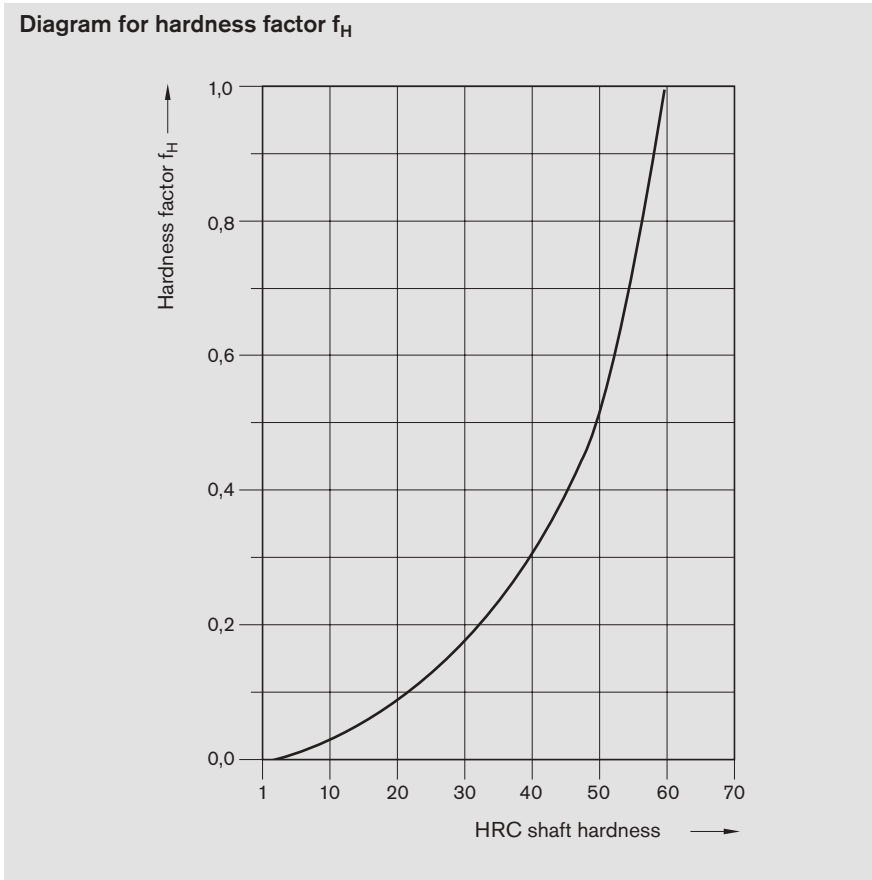

Temperature factor

For standard linear bushings only

Bearing temperature (°C)	100	125	150	175	200
Temperature factor f _t	1	0.92	0.85	0.77	0.70

Short stroke factor

Short stroke means the stroke length of eLINE, compact, super and segmental linear bushings is less than three times the overall length of the linear bushing. In this instance, the service life of the shaft is less than that of the linear bushing. See the technical data for each linear bushing for more information. When the stroke is more than three times the overall length of the linear bushing, the short stroke factor f_s = 1.

Equivalent dynamic bearing load

When bearing load varies in the same load direction, the equivalent dynamic load F_m is calculated as follows:

$$F_m = \sqrt[3]{|F_1|^3 \times \frac{q_{s1}}{100\%} + |F_2|^3 \times \frac{q_{s2}}{100\%} + \dots + |F_n|^3 \times \frac{q_{sn}}{100\%}}$$

For varying directions of load, the resulting load must then be calculated. Preloads and any pitching torque must also be factored into the life expectancy calculation.

- F_m = Equivalent dynamic bearing load (N)
- $F_1, F_2 \dots F_n$ = Stepped individual dynamic loads in stages 1 to n (N)
- $q_{s1}, q_{s2} \dots q_{sn}$ = Travel ratios for $F_1 \dots F_n$ (%)
- n = No. stages (-)

Determining load rating

The following formula can be used for the estimate:

$$C_{req} = \frac{F_m}{f_H \times f_t \times f_s \times f_L}$$

- C_{req} = Required dynamic load rating (N)
- F_m = Equivalent dynamic bearing load (N)
- f_H = Shaft hardness factor (-)
- f_t = Temperature factor (-)
- f_s = Short stroke factor (for segmental, compact, eLINE and super linear bushings) (-)
- f_L = Service life factor (-)

Impact of service life

Diagram for service life factor f_L

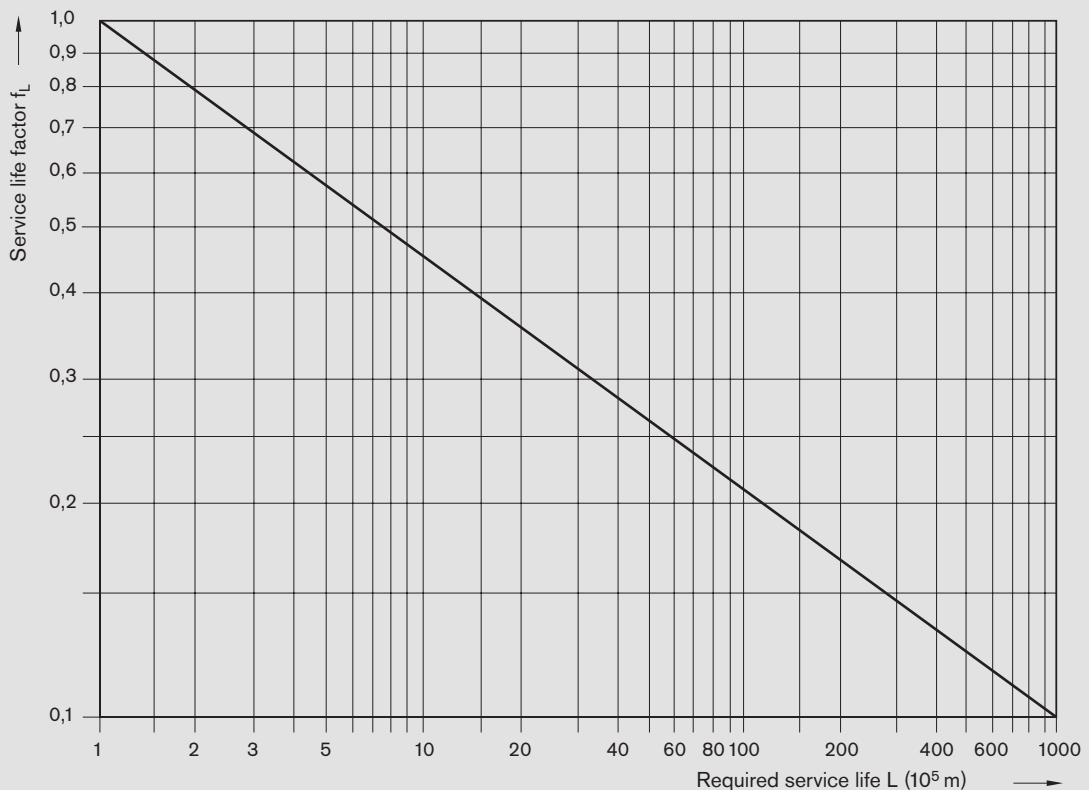

Life expectancy calculation

Load ratings

Dimensions (mm) Shaft	Load ratings (N)															
	eLINE, compact linear bushings		Super linear bushings						Standard linear bushings		Segmental linear bushings		Radial linear bushings			
	∅ d	C	C ₀	<u>A</u> , <u>B</u>	C	C ₀	<u>H</u>	C	C ₀	<u>SH</u>	C	C ₀	C	C ₀	C	C ₀
3	-	-	-	-	-	-	-	-	-	-	55	45	-	-	-	-
4	-	-	-	-	-	-	-	-	-	-	70	60	-	-	-	-
5	-	-	-	-	-	-	-	-	-	-	180	140	-	-	-	-
8	500	350	-	-	-	-	-	-	-	-	320	240	-	-	-	-
10	600	410	600	330	-	-	-	-	-	-	300	260	-	-	-	-
12	730	420	830	420	-	-	-	-	-	-	420	280	480	420	-	-
14	760	430	-	-	-	-	-	-	-	-	-	-	-	-	-	-
16	950	500	1,020	530	-	-	-	-	-	-	580	440	720	620	-	-
20	1,120	610	2,020	1,050	2,520	1,880	3,530	2,530	1,170	860	1,020	870	-	-	-	-
25	2,330	1,310	3,950	2,180	4,430	3,360	6,190	4,530	2,080	1,560	1,630	1,360	-	-	-	-
30	3,060	1,880	4,800	2,790	6,300	5,230	8,800	7,180	2,820	2,230	2,390	1,960	8,500	9,520	-	-
40	5,040	3,140	8,240	4,350	9,680	7,600	13,500	10,400	5,170	3,810	3,870	3,270	13,900	16,000	-	-
50	5,680	3,610	12,060	6,470	16,000	12,200	22,300	16,800	8,260	6,470	-	-	20,800	24,400	-	-
60	-	-	-	-	23,500	18,700	-	-	11,500	9,160	-	-	29,500	34,100	-	-
80	-	-	-	-	-	-	-	-	21,000	16,300	-	-	54,800	61,500	-	-

Note on dynamic load ratings

Dynamic load ratings are determined based on a total travel of 100,000 m. When based on 50,000 m, the value C in the table is multiplied by 1.26.

Static load safety factor

The static load safety factor S_0 is used to avoid unacceptable permanent deformations in the tracks and rolling elements. It is the ratio of the static load rating C_0 to the highest load F_{0max} . The highest amplitude is decisive here, even if it only occurs briefly.

$$S_0 = \frac{C_0}{F_{0max}}$$

S_0 = Static load safety factor (-)
 C_0 = Static load rating (N)
 F_{0max} = Maximum static load (N)

Static load safety factor recommendations for various operating conditions

Operating conditions	S_0
Normal operating conditions	1 ... 2
Minor shocks and vibrations	2 ... 4
Moderate shocks and vibrations	3 ... 5
Severe shocks and vibrations	4 ... 6
Unknown load parameters	6 ... 15

Sample calculation

The vertical load of a slide on both shafts is 800 N.
 It is assumed that the load is evenly distributed across the four linear bushings.
 The slide travels along a stroke length of 0.2 m with a stroke repetition rate n_s of 30 double strokes/min.
 The service life L_{hrs} should be at least 8,000 hours.
 The operating temperature is between 0 °C and 80 °C. Precision steel shafts with a minimal HRC of 60 and eLINE linear bushings should be used.
 Operating conditions include minor shocks and vibrations.

Determining linear bushing size

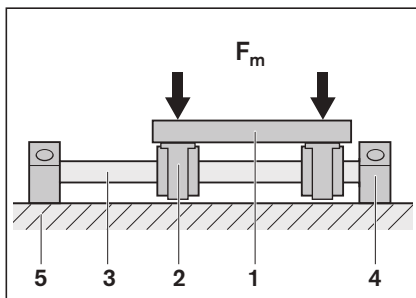

- 1 Slides
- 2 Linear set (linear bushing in housing)
- 3 Precision steel shaft
- 4 Shaft support block
- 5 Mounting base

Since all four linear bushings are under the same load, the result is the load per linear bushing:

$$F_m = \frac{800 \text{ N}}{4} = 200 \text{ N}$$

F_m = Equivalent dynamic bearing load (per linear bushing) (N)

Service life L as total travel in meters is calculated as follows:

$$L = 2 \times s \times n_s \times 60 \times L_{hrs}$$

$$L = 2 \times 0.2 \times 30 \times 60 \times 8,000$$

$$L = 57.6 \times 10^5 \text{ m}$$

L = Nominal service life (m)
 L_{hrs} = Nominal service life (hrs)
 s = Stroke length (m)
 n_s = Stroke repetition rate (rpm)

The "Service life factor f_L " diagram shows a service life factor f_L of 0.25 for the calculated service life of 57.6×10^5 m.

A shaft hardness of HRC 60 in the "Diagram for hardness factor f_H " produces a hardness factor f_H of 1.

The temperature factor $f_t = 1$ (as per table)

Since there is no short stroke, the short stroke factor $f_s = 1$.

The required load rating C_{req} is then calculated:

$$C_{req} = \frac{F_m}{f_H \times f_t \times f_s \times f_L}$$

$$C_{req} = \frac{200}{1 \times 1 \times 1 \times 0.25}$$

$$C_{req} = 800 \text{ N}$$

C_{req} = Required dynamic load rating (N)
 F_m = Equivalent dynamic bearing load (N)

The linear bushing with the next highest load rating would be R0658 252 44.
 Since the orientation of the linear bushings to load direction cannot be clearly defined, the minimum load ratings are used.
 Dynamic load rating $C_{min} = 950 \text{ N}$.
 Static load rating $C_{0min} = 500 \text{ N}$.

Life expectancy calculation

Calculating nominal service life

Using the following formula for the selected linear bushing R0658 252 44:

$$L = \left(\frac{C}{F_m} \times f_H \times f_t \times f_s \right)^3 \cdot 10^5$$

L = Service life (m)

The nominal service life can be calculated in meters using the following values:

Dynamic load rating	C =	950 N
Equivalent dynamic bearing load	F _m =	200 N
Hardness factor	f _H =	1
Temperature factor	f _t =	1
Short stroke factor	f _s =	1

$$L = \left(\frac{950}{200} \times 1 \times 1 \times 1 \right)^3 \times 10^5$$

$$L = 107 \times 10^5 \text{ m}$$

L = Service life (m)

The service life in hours is converted to operating hours using the following formula:

$$L_{\text{hrs}} = \frac{L}{2 \times s \times n_s \times 60}$$

$$L_{\text{hrs}} = \frac{107 \times 10^5}{2 \times 0.2 \times 30 \times 60}$$

$$L_{\text{hrs}} = 14,861 \text{ hrs}$$

L_{hrs} = Service life (hrs)

s = Stroke length (m)

n_s = Stroke repetition rate (rpm)

This would cover the required minimum service life of 8,000 hours.

Calculating static load safety factor

Using the following formula for the selected linear bushing R0658 252 44:

$$S_0 = \frac{C_0}{F_{0\text{max}}}$$

S₀ = Static load safety factor (-)

C₀ = Static load rating (N)

F_{0max} = Maximum static load (N)

The static load safety factor can be calculated:

Static load rating C₀ = 500 N

Maximum static load F_{0max} = 200 N

$$S_0 = \frac{500}{200} = 2.5$$

S₀ = Static load safety factor (-)

The operating conditions in the sample calculation require a static load safety factor S₀ of 2 ... 4 that is met by the calculated value.

Lubrication

Note

The usual rolling bearing requirements apply for lubrication. Linear bushings come with a preservative that is compatible with all mineral oil-based lubricants. Oil or grease can be used. Grease is preferable since it helps create a seal and adheres better to the linear bushing. Linear bushings only have to be lubricated periodically. Please follow the lubricant manufacturer's instructions. Linear sets are designed for grease. When lubricating with oil, make sure all rolling elements have been reached.

Grease

For lubrication, we recommend a grease in compliance with DIN 51825:

- K2K
- KP2K (for higher loads)

With Dynalub 510, Rexroth offers a lithium-based high-performance grease specially engineered for linear motion technology. It is highly water-resistant and anticorrosive. We recommend Dynalub 520 for miniature applications.

Material number	Description			Consistency classification under DIN 51818	Temperature range (°C)	Packaging unit	Area of application
	Rexroth	DIN 51825	DIN 51826				
R3416 037 00	Dynalub 510	KP2K-20		2	-20 to 80	1 x 400 g	Shaft d ≥ 8 mm
R0419 090 01	Dynalub 520		GP00K-20	00	-20 to 80	5 ml maintenance kit	Shaft d < 8 mm
R3416 043 00	Dynalub 520		GP00K-20	00	-20 to 80	1 x 400 g	Shaft d < 8 mm

Oil

When ease of movement is required, linear bushings can be lubricated with oil. The following table lists oils with different viscosity:

ISO viscosity under DIN 51519	Kinematic viscosity at 40 °C (mm ² /s)	Application
ISO VG 32	32	For minor friction and load
ISO VG 68	68	
ISO VG 100	100	
ISO VG 320	320	For low speed and/or high load
ISO VG 460	460	

Initial lubrication

Before start-up, lubricate any linear bushings/linear sets that have not had initial lubrication.

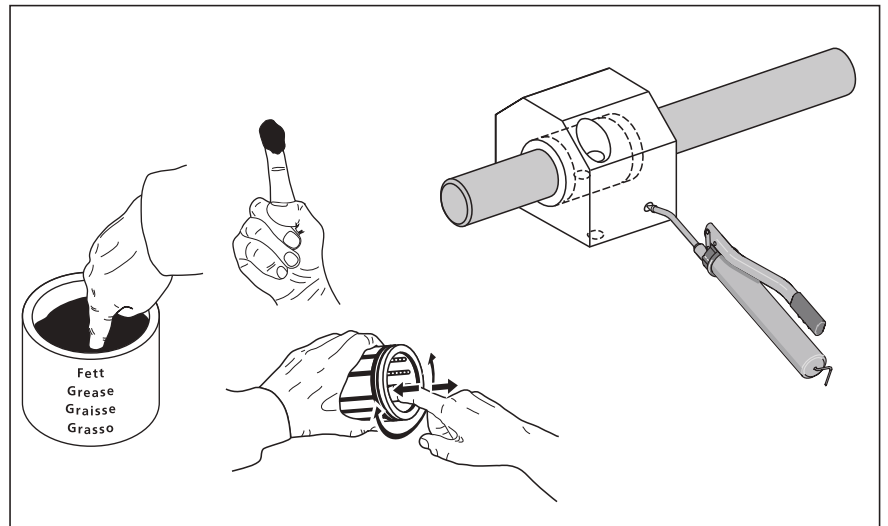

Lubrication

Relubricating options for linear bushings

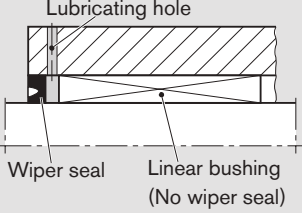
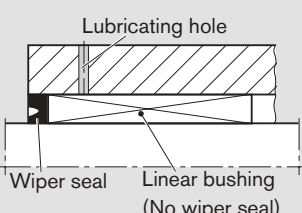
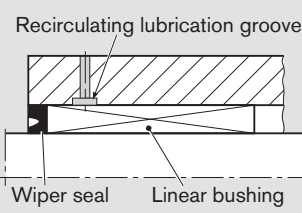
Linear bushing models	Lubrication through gap between linear bushing and wiper seal	Lubrication through lubricating hole	Lubrication through lubricating hole with lubrication groove
eLINE, compact	 <p>Axial securing of wiper seal and linear bushing required</p>	 <p>Lubrication causes pressure to build. Always make sure the linear bushing and wiper seal are firmly attached.</p>	 <p>● Place lubricating hole parallel to the visible ball recirculating track</p>
Super \bar{A}, \bar{B} - Closed - Open	● ●	See Super linear bushings \bar{A} , \bar{B} – Technical data – “Customer-built housing”	
Standard - Closed - Adjustable	● ●	● Place lubricating hole near longitudinal slot (directed mounting)	
- Open	●		
Segmental	●		● Place lubricating hole parallel to the visible ball recirculating track

Notes:

Make sure open linear bushings are adequately secured. Relubricate during linear motion when possible. Lubricating hole and lubrication groove must be burr-free.

Lube nipples

Relubricatable linear sets come with lubricating holes for grease. Compatible lube nipples are listed in the following table:

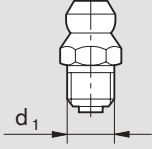
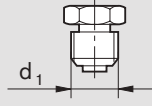
		
d₁	Hydraulic-type lube nipple DIN 71412 Form A	Funnel-type lube nipple DIN 3405 Form A
(mm)	Material number	Material number
M6	R3417 002 02	R3417 001 05
M8x1	R3417 003 02	R3417 003 05
M10x1	R3417 009 02	-

Reference values for load-dependent relubrication

- Initial lubrication (no relubrication)
- Regularly relubricated

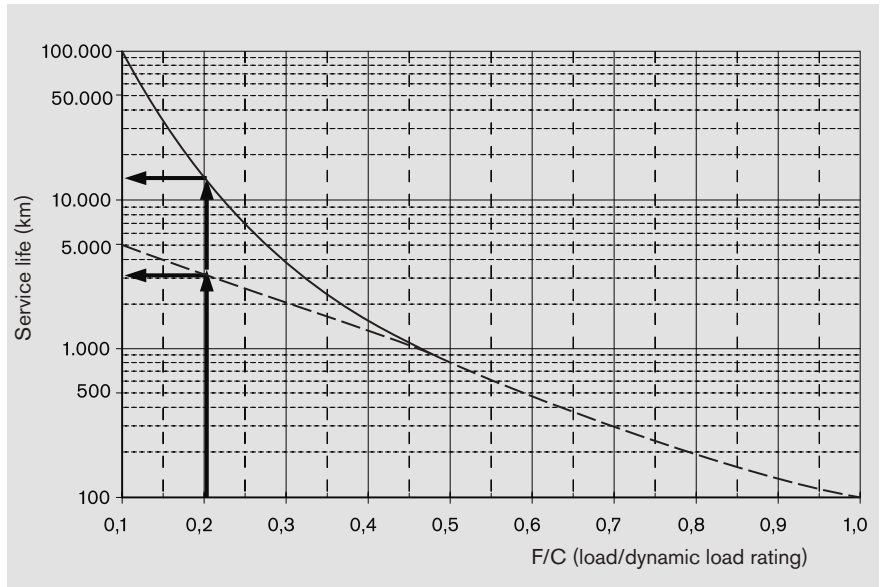

The diagram shows reference values for load-dependent relubrication.

Example

If an eLINE linear bushing is loaded to 20% of the dynamic load rating, its service life with initial lubrication is 3,000 km under test conditions.

When relubricated every 3,000 km, this service life can be extended to 12,500 km.

Factors

Relubricating or changing the grease of linear bearings depends on numerous factors.

Some of these are listed below:

- Load
- Speed
- Motion sequence
- Temperature

Short lubricating intervals given:

- Heavy load
- High speed (up to v_{max})
- Short stroke (stroke is less than three times the overall length of the linear bushing)
- Low lubricant durability

Relubricatable linear sets

For initial lubrication and relubrication through lubricating hole:
Lubricate on shaft until lubricant emerges.

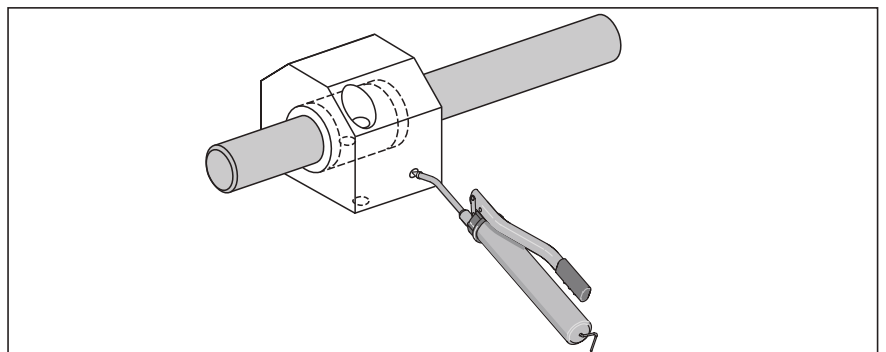

Installation

Installing the linear bushings

Guides with only one shaft should have two linear bushings.
Guides with two shafts should have at least one shaft through two linear bushings.
High standards must be placed regarding the differences in distance between two

Parallelism

shafts with linear bushings as well as how parallel the shafts and linear bearings are in order to avoid warping, thereby reducing service life and increased idling friction. The table contains guideline values for the maximum difference in distance **P** including parallelism offset in guides with linear bushings.



Shaft Ø d (mm)	P (µm)			
	Zero-clearance Standard super linear bushing	Segmental eLINE, compact linear bushing	h6/H7 Standard super linear bushing	Segmental compact linear bushing
3	3	–	9	–
4	3	–	9	–
5	4	–	12	–
8	4	7	12	15
10	4	7	12	15
12	5	8	13	17
14	5	8	13	17
16	5	8	13	17
20	7	12	15	20
25	9	15	17	23
30	9	15	17	23
40	11	18	19	25
50	13	22	21	28
60	16	–	24	–
80	22	–	30	–

Operating temperatures

-10 °C to +80 °C

Only unsealed standard linear bushings with steel ball retainers may be used at higher temperatures. This reduces the load rating.
Avoid ice buildup at negative temperatures.

Shaft deflection

The service life of self-supporting linear bushing guides is impacted due to shaft deflection and the resulting angular pressure when the linear bushings have rigid connecting structures (housing, etc.) and there is a longer distance between shaft supports (does not apply to super linear bearings ,  and  up to 30 ft). Calculating shaft deflection: see technical data on steel shafts.

Stainless steel linear bushings

Stainless steels as per ISO 683-17/EN 10088. Parts in particularly critical, corrosive environments must be inspected under operating conditions. Use suitable preservatives and lubricants.

Housing bore

The operating clearance of all linear bushings can be influenced by the choice of shaft and bore tolerance (exception: closed standard linear bushings).

The following applies for an h6 shaft:

Normal DIN operating clearance calls for housing bore tolerance H7. For smaller and larger bores, the operating clearance changes accordingly. We recommend bore tolerance K7 for minimal-clearance guides. Bore tolerance M7 is designed for moderate preload (preload reduces the service life of linear bushings and shafts). eLINE linear bushings with a bore tolerance of H7 produce minimal-clearance guides.

Radial clearance

The radial clearance values for linear bushings and linear sets shown in the table have been determined from statistics and correspond to values expected in practice.

Adjusting radial clearance

The radial clearance of a linear bushing on zero-clearance guides must be reduced using the adjusting screw on the housing until there is slight resistance when rotating the shaft. Secure the adjusting screw for applications where vibrations are present. The radial clearance of closed standard linear bushings cannot be adjusted.

Adjusting preload

For preloading, the aforementioned adjustment is made using an adjustment shaft that is weaker by the degree of preload.

Vertical dimension

The linear set tables show tolerances for the vertical dimension "H". These tolerances have been determined from statistics and correspond to values expected in practice.

Securing

See "Technical data" for the various linear bushings.

Notes on mounting

The housing bore must be chamfered. Small linear bushings (except eLINE and compact linear bushings with a shaft diameter of 12 or higher) can be mounted manually. For larger diameters as well as eLINE and compact linear bushings, a mandrel should be used. While doing so, make sure that the press-fit force is not transmitted through wiper seals and steel retainers (standard linear bushings), since this can damage the bearing races.

If eLINE and compact linear bushings are slightly skewed when initially installing them into the housing bore, they will align themselves as they are pressed in.

Removal and realignment are not necessary.

The ends of the shaft must be chamfered. Make sure the linear bearing is not skewed when pressing it onto the shaft.

Striking linear bushing sleeves, retainers or races with a hammer will result in damage.

Do not press linear bushings with wiper seals over sharp edges on the shaft since the sealing lips will be damaged.

See "Installation" for each linear bushing model for notes on installing torque-resistant linear bushings.

Mandrel

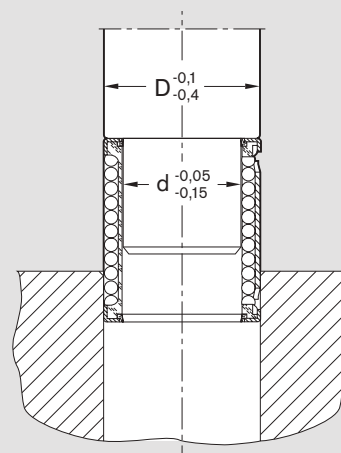

Tolerance tables

Inner dimensions

Nominal size range (mm)	Dimensions (μm) = 0.001 mm															
	G7	H5	H6	H7	H8	H11	H12	H13	JS6	JS7	JS14	K6	K7	M6	M7	P9
> 3	+16	+5	+8	+12	+18	+75	+120	+180	+4	+6	+150	+2	+3	-1	0	-12
≤ 6	+4	0	0	0	0	0	0	0	-4	-6	-150	-6	-9	-9	-12	-42
> 6	+20	+6	+9	+15	+22	+90	+150	+220	+4.5	+7.5	+180	+2	+5	-3	0	-15
≤ 10	+5	0	0	0	0	0	0	0	-4.5	-7.5	-180	-7	-10	-12	-15	-51
> 10	+24	+8	+11	+18	+27	+110	+180	+270	+5.5	+9	+215	+2	+6	-4	0	-18
≤ 18	+6	0	0	0	0	0	0	0	-5.5	-9	-215	-9	-12	-15	-18	-61
> 18	+28	+9	+13	+21	+33	+130	+210	+330	+6.5	+10.5	+260	+2	+6	-4	0	-22
≤ 30	+7	0	0	0	0	0	0	0	-6.5	-10.5	-260	-11	-15	-17	-21	-74
> 30	+34	+11	+16	+25	+39	+160	+250	+390	+8	+12.5	+310	+3	+7	-4	0	-26
≤ 50	+9	0	0	0	0	0	0	0	-8	-12.5	-310	-13	-18	-20	-25	-88
> 50	+40	+13	+19	+30	+46	+190	+300	+460	+9.5	+15	+370	+4	+9	-5	0	-32
≤ 80	+10	0	0	0	0	0	0	0	-9.5	-15	-370	-15	-21	-24	-30	-106
> 80	+47	+15	+22	+35	+54	+220	+350	+540	+11	+17.5	+435	+4	+10	-6	0	-37
≤ 120	+12	0	0	0	0	0	0	0	-11	-17.5	-435	-18	-25	-28	-35	-124
> 120	+54	+18	+25	+40	+63	+250	+400	+630	+12.5	+20	+500	+4	+12	-8	0	-43
≤ 180	+14	0	0	0	0	0	0	0	-12.5	-20	-500	-21	-28	-33	-40	-143
> 180	+61	+20	+29	+46	+72	+290	+460	+720	+14.5	+23	+575	+5	+13	-8	0	-50
≤ 250	+15	0	0	0	0	0	0	0	-14.5	-23	-575	-24	-33	-37	-46	-165

Outer dimensions

Nominal size range (mm)	Dimensions (μm) = 0.001 mm															
	g7	h5	h6	h7	h8	h11	h12	h13	js6	js7	js14	k6	k7	m6	m7	p9
> 3	-4	0	0	0	0	0	0	0	+4	+6	+150	+9	+13	+12	+16	+42
≤ 6	-16	-5	-8	-12	-18	-75	-120	-180	-4	-6	-150	+1	+1	+4	+4	+12
> 6	-5	0	0	0	0	0	0	0	+4.5	+7.5	+180	+10	+16	+15	+21	+51
≤ 10	-20	-6	-9	-15	-22	-90	-150	-220	-4.5	-7.5	-180	+1	+1	+6	+6	+15
> 10	-6	0	0	0	0	0	0	0	+5.5	+9	+215	+12	+19	+18	+25	+61
≤ 18	-24	-8	-11	-18	-27	-110	-180	-270	-5.5	-9	-215	+1	+1	+7	+7	+18
> 18	-7	0	0	0	0	0	0	0	+6.5	+10.5	+260	+15	+23	+21	+29	-
≤ 30	-28	-9	-13	-21	-33	-130	-210	-330	-6.5	-10.5	-260	+2	+2	+8	+8	-
> 30	-9	0	0	0	0	0	0	0	+8	+12.5	+310	+18	+27	+25	+34	-
≤ 50	-34	-11	-16	-25	-39	-160	-250	-390	-8	-12.5	-310	+2	+2	+9	+9	-
> 50	-10	0	0	0	0	0	0	0	+9.5	+15	+370	+21	+32	+30	+41	-
≤ 80	-40	-13	-19	-30	-46	-190	-300	-460	-9.5	-15	-370	+2	+2	+11	+11	-
> 80	-12	0	0	0	0	0	0	0	+11	+17.5	+435	+25	+38	+35	+48	-
≤ 120	-47	-15	-22	-35	-54	-220	-350	-540	-11	-17.5	-435	+3	+3	+13	+13	-
> 120	-14	0	0	0	0	0	0	0	+12.5	+20	+500	+28	+43	+40	+55	-
≤ 180	-54	-18	-25	-40	-63	-250	-400	-630	-12.5	-20	-500	+3	+3	+15	+15	-
> 180	-15	0	0	0	0	0	0	0	+14.5	+23	+575	+33	+50	+46	+63	-
≤ 250	-61	-20	-29	-46	-72	-290	-460	-720	-14.5	-23	-575	+4	+4	+17	+17	-

eLINE and compact linear bushings

Product overview

The benefits

- Low-cost linear bushing for general requirements
- Small outer dimensions and highly compact construction
- Integrated metal retainer about 0.1 mm larger than outer diameter (shaft diameters 12 to 50) for secure fit in housing bore
- Easy installation: just press on – no additional securing needed
- High load rating and long service life due to hardened segmental load-bearing plates with ball conformity in the track.
- High travel speed (5 m/s)
- Many pockets acting as lubricant reservoirs for extended lubrication intervals or lubrication for life.
- Pockets also collect any dirt that may have worked its way in to prevent the linear bushing from jamming.
- Integrated wiper seals, top wiper seals or no wiper seals
- Also available in stainless steel for medical, chemistry and food industries
- Linear sets with aluminum housing
- Lubricated for life (eLINE)



R0658 page 32
Shaft diameters 8 and 10



R0658 page 32
Shaft diameters 12 to 50

Explanation of short product name

Sample linear bushing: **eLINE linear bushing**
KBC-12-DD-RT-NR-G

Definition of codes		KB	C	12	DD	RT	NR	G
Type	Linear bushing	=	KB					
Series	Compact	=	C					
Shaft diameter		=		12				
Seals	With two seals	=			DD			
	1 seal	=			D			
	No seals	=						
Radial clearance	Reduced radial clearance (eLINE linear bushing)	=				RT		
	Normal radial clearance (compact linear bushing)	=						
Linear bushing version	Stainless steel	=					NR	
	Normal	=						
Linear bushing lubrication	Greased	=						G
	Not greased	=						

eLINE and compact linear bushings

Technical data, installation

Please observe general technical principles and follow the lubricating and installation instructions.

- Seal** The sealed version contains integrated seals.
Separate wiper seals are also available (no securing necessary).
- Friction** The friction coefficients μ of the unsealed linear bushings are 0.001 – 0.004 when lubricated with oil.
The friction coefficient is lowest under heavy load, but can still be above the specified value even under low load.
The table shows the friction generated by linear bushings with integrated seals on both ends when not under radial load. They depend on speed and lubrication.

Shaft \varnothing d (mm)	Breakaway force ¹⁾	Friction ¹⁾
	Reference value (N)	Reference value (N)
8	0.8	0.4
10	1.0	0.5
12	1.5	0.8
14	1.8	0.9
16	2.0	1.0
20	3.0	1.5
25	4.5	2.0
30	6.0	2.5
40	8.0	3.0
50	10.0	4.0

1) When separate wiper seals are used, the values must be multiplied by 1.5.

Speed $v_{\max} = 5 \text{ m/s}$

Acceleration $a_{\max} = 150 \text{ m/s}^2$

Operating temperature $-10 \text{ }^{\circ}\text{C}$ to $80 \text{ }^{\circ}\text{C}$

Initial lubrication Compact linear bushings do not have an initial lubrication. Grease linear bushings before use, see "Initial lubrication" section "Lubrication" on page 21.
eLINE linear bushings come with initial lubrication.
Service life data is based on initial lubrication and relubricated linear bushings.

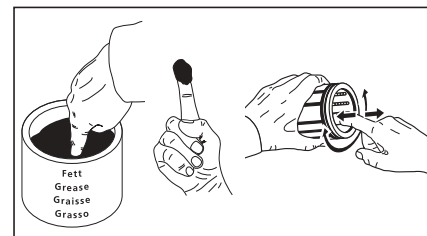

Installation Install the linear bushings using an arbor press (see "Installation instructions" below).
If linear bushings are slightly skewed when initially installing them into the housing bore, they will align themselves as they are pressed in. The linear bushing does not have to be removed and realigned.

Securing Shaft diameters 8 and 10: The plastic outer sleeve is oversized.
Additional securing is required for vibrations or high acceleration.
Shaft diameters 12 to 50: The outer diameter of the metal retainer is oversized.
No additional securing needed (bore length $\geq C$).

Effect of load direction on load rating

Depending on installation, the listed load ratings should be chosen at the minimum or maximum position and should be based on the calculations.

If the load direction is clearly defined and the linear bushings can be installed at the maximum position, the load ratings C_{max} (dynamic load rating) and C_{0max} (static load rating) can be used. If directed installation is not possible or the load direction is not defined, the minimum load ratings must be used.

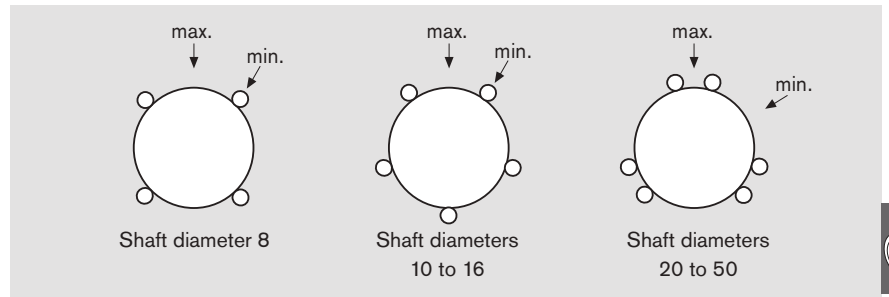

Reduced load rating with short stroke

When short stroke is present, the service life of the shaft is less than that of the linear bushing.

The load ratings C in the tables must therefore be multiplied by the factor f_s .

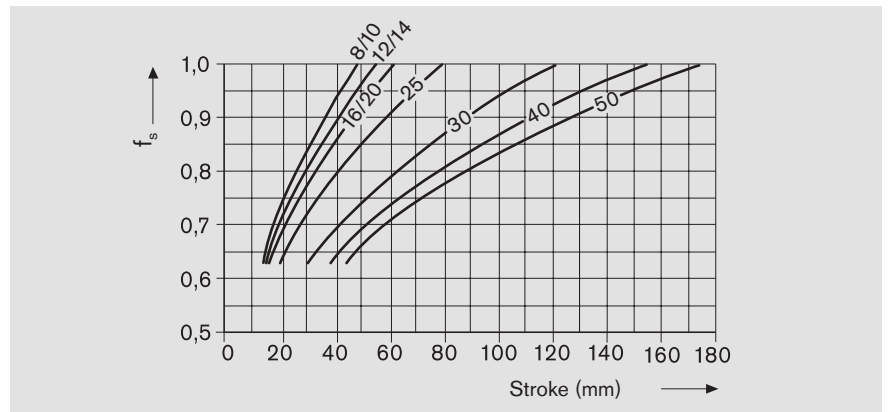

Wiper seals

Design

- Galvanized metal case
- Elastomer wiper seal

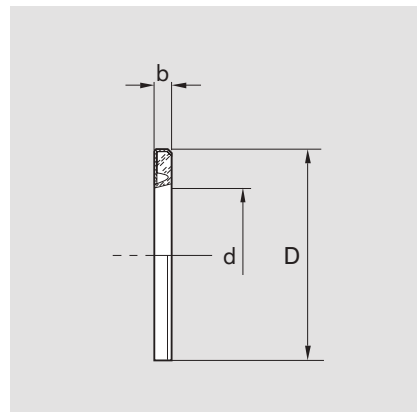

Shaft Ø d (mm)	Material number	Dimen- sions (mm)		Weight (g)
		D ¹⁾	b	
12	R1331 812 10	19	3	1.1
16	R1331 816 10	24	3	1.5
20	R1331 820 10	28	4	2.4
25	R1331 825 10	35	4	4.4
30	R1331 830 10	40	4	5.0
40	R1331 840 10	52	5	5.0
50	R1331 850 10	62	5	10.0

1) Outer diameter D is oversized by about 0.1 mm. No additional securing is needed.

eLINE and compact linear bushings

eLINE linear bushings, R0658**Design**

- POM ball retainer
- Integrated wiper seals
- Balls made of rolling bearing steel
- Hardened segmental steel plates
- Metal retainers (shaft diameter 12 and higher)
- Reduced radial clearance for applications where **minimal-clearance** bearings with an H7 bore are desired
- Initial lubrication with Dynalub 510
- Stainless steel version also available: Segmental steel plates made of 1.4037 balls made of 1.3541

Compact linear bushings, R0658**Design**

- **Normal** radial clearance
- Not greased
- Optional integrated wiper seals

Shaft diameters 8 and 10

Shaft Ø d (mm)	Material number without wiper seals		Weight (kg)
	Compact linear bushings Normal KBC- ...	Stainless KBC- ... -NR	
8	R0658 008 00	R0658 008 30	0.011
10	R0658 010 00	R0658 010 30	0.014
12	R0658 012 00	R0658 012 30	0.016
14	R0658 014 00	R0658 014 30	0.018
16	R0658 016 00	R0658 016 30	0.025
20	R0658 020 00	R0658 020 30	0.028
25	R0658 025 00	R0658 025 30	0.058
30	R0658 030 00	R0658 030 30	0.080
40	R0658 040 00	R0658 040 30	0.140
50	R0658 050 00	R0658 050 30	0.170

Shaft diameters 12 to 50

Shaft Ø d (mm)	Material number with two integrated wiper seals				Weight (kg)
	eLINE linear bushings (reduced radial clearance, prelubricated)		Compact linear bushings ¹⁾ (Normal radial clearance, not prelubricated)		
	KBC- ... -DD-RT-G Normal	KBC- ... -DD-RT-NR-G Stainless	KBC- ... -DD Normal	KBC- ... -DD-NR Stainless	
8	R0658 262 44	R0658 262 34	R0658 208 40	R0658 208 30	0.011
10	R0658 261 44	R0658 261 34	R0658 210 40	R0658 210 30	0.014
12	R0658 251 44	R0658 251 34	R0658 212 40	R0658 212 30	0.016
14	–	–	R0658 214 40	R0658 214 30	0.018
16	R0658 252 44	R0658 252 34	R0658 216 40	R0658 216 30	0.025
20	R0658 253 44	R0658 253 34	R0658 220 40	R0658 220 30	0.028
25	R0658 254 44	R0658 254 34	R0658 225 40	R0658 225 30	0.058
30	R0658 255 44	R0658 255 34	R0658 230 40	R0658 230 30	0.080
40	R0658 256 44	R0658 256 34	R0658 240 40	R0658 240 30	0.140
50	–	–	R0658 250 40	R0658 250 30	0.170

¹⁾ Integrated seal: R0658 1...40 or R0658 1 to 30

Explanation of sample short product name

KB	C	12	DD	RT	G
Linear bushing	Compact	Ø 12	With two seals	Reduced radial clearance	Greased

See page 28 for more information on short product names.

Dimensions

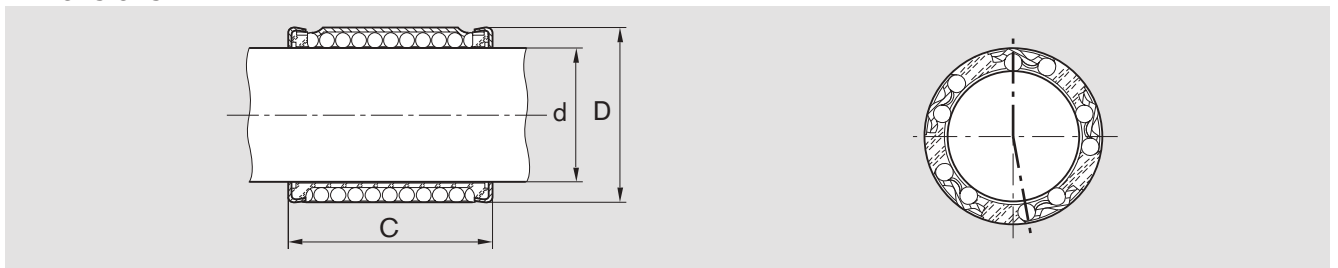

Dimensions (mm)			Rows of balls	Radial clearance (µm)		Load ratings (N)							
Ø d	D	C ±0.2		eLINE h6/H7	Compact h6/H7	Normal				Stainless			
						min.	dyn. C max.	min.	stat. C ₀ max.	min.	dyn. C max.	min.	stat. C ₀ max.
8	15	24	4	+5 -18	+25 +2	500	580	350	500	350	410	280	400
10	17	26	5	+5 -18	+25 +2	600	720	410	600	420	500	330	480
12	19	28	5	+8 -24	+32 0	730	870	420	620	510	610	340	500
14	21	28	5	-	+32 0	760	900	430	630	530	630	340	500
16	24	30	5	+8 -24	+32 0	950	1,120	500	730	660	780	400	580
20	28	30	6	+9 -25	+33 -1	1,120	1,410	610	900	780	990	480	720
25	35	40	6	+12 -24	+36 0	2,330	2,930	1,310	1,950	1,630	2,050	1,050	1,560
30	40	50	6	+12 -24	+36 0	3,060	3,250	1,880	2,790	2,140	2,700	1,510	2,230
40	52	60	6	+18 -25	+42 -1	5,040	6,380	3,140	4,650	3,520	4,470	2,510	3,720
50	62	70	6	-	+42 -1	5,680	7,180	3,610	5,350	3,970	5,030	2,890	4,280

The dynamic load ratings are based on total travel of 100,000 m.
 When based on 50,000 m, the C values in the table are multiplied by 1.26.



eLINE and compact linear sets

eLINE linear sets, R1027 Closed, normal or stainless

Design

- eLINE linear bushing
- Lightweight precision housing (aluminum)
- Integrated wiper seals
- **Reduced radial clearance**
- Initial lubrication with Dynalub 510
- Also available in stainless steel under KBC-NR



Compact linear sets, R1027 Closed, normal or stainless

Design

- Compact linear bushing
- Lightweight precision housing (aluminum)
- Integrated wiper seals
- **Normal radial clearance**
- Initial lubrication with Dynalub 510
- Also available in stainless steel under KBC-NR

Compact linear sets, R1028 Adjustable, normal

Design

- Compact linear bushing
- Lightweight precision housing (aluminum)
- Integrated wiper seals
- **Set to zero clearance**
- Initial lubrication with Dynalub 510

Shaft Ø d (mm)	Material number with eLINE linear set Reduced radial clearance, prelubricated		Weight (kg)
	Normal LSAC- ... -DD-RT-G	Stainless LSAC- ... -DD-RT-NR-G	
12	R1027 251 44	R1027 251 34	0.08
16	R1027 252 44	R1027 252 34	0.11
20	R1027 253 44	R1027 253 34	0.15
25	R1027 254 44	R1027 254 34	0.27
30	R1027 255 44	R1027 255 34	0.40
40	R1027 256 44	R1027 256 34	0.75

Shaft Ø d (mm)	Material number with compact linear set Prelubricated		Weight (kg)
	Normal LSAC- ... -DD-G	Stainless LSAC- ... -DD-NR-G	
12	R1027 212 44	R1027 212 34	0.08
16	R1027 216 44	R1027 216 34	0.11
20	R1027 220 44	R1027 220 34	0.15
25	R1027 225 44	R1027 225 34	0.27
30	R1027 230 44	R1027 230 34	0.40
40	R1027 240 44	R1027 240 34	0.75
50	R1027 250 44	R1027 250 34	1.20



Shaft Ø d (mm)	Material number with compact linear set Normal, prelubricated		Weight (kg)
	LSACE- ... -DD-G		
12	R1028 212 44		0.08
16	R1028 216 44		0.11
20	R1028 220 44		0.15
25	R1028 225 44		0.27
30	R1028 230 44		0.40
40	R1028 240 44		0.75
50	R1028 250 44		1.20

Explanation of sample short product name

LS	A	C	12	DD	RT	NR	G
Linear set	Aluminum	Compact	Ø 12	With two seals	Reduced radial clearance	Stainless steel	Greased

See page 28 for more information on short product names.

Dimensions

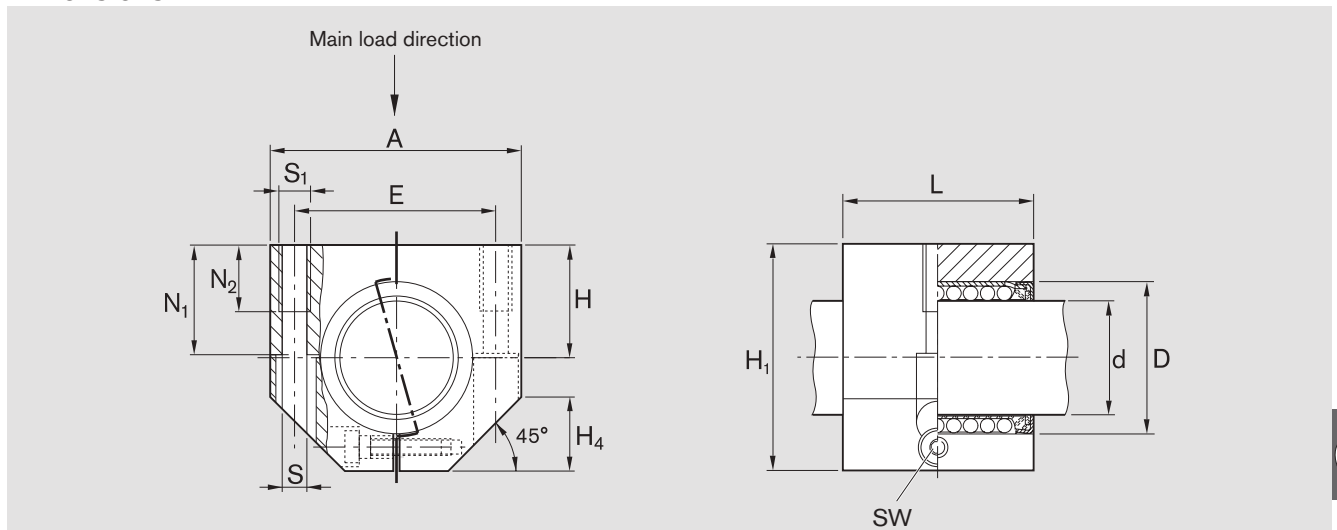

Dimensions (mm)												
Ø d	D	H	H ₁	A	L	E ±0.15	S ¹⁾	S ₁	N ₁	N ₂	H ₄	SW
12	19	17	33	40	28	29	4.3	M5	16	11	11	2.5
16	24	19	38	45	30	34	4.3	M5	18	11	13	2.5
20	28	23	45	53	30	40	5.3	M6	22	13	15	3.0
25	35	27	54	62	40	48	6.6	M8	26	18	17	4.0
30	40	30	60	67	50	53	6.6	M8	29	18	19	4.0
40	52	39	76	87	60	69	8.4	M10	38	22	24	5.0
50	62	47	92	103	70	82	10.5	M12	46	26	30	6.0

Ø d (mm)	Radial clearance (µm)			Tolerance for H ²⁾ (µm)		Load ratings ³⁾ (N)			
	R1027 eLINE, compact h6	R1027 Compact h6	R1028	R1027	R1028	Normal		Stainless	
						dyn. C	stat. C ₀	dyn. C	stat. C ₀
12	+8	+32	Comes clamped to h5 shaft (lower limit) and set to zero clearance	+24	+12	810	490	570	390
	-24	0		0	-12				
16	+8	+32		+24	+12	1,050	570	730	460
	-24	0		0	-12				
20	+9	+33		+25	+13	1,410	900	990	720
	-25	-1		0	-12				
25	+12	+36		+25	+13	2,930	1,950	2,050	1,560
	-24	0		0	-12				
30	+12	+36	+25	+13	3,850	2,790	2,700	2,230	
	-24	0	0	-12					
40	+18	+42	+26	+14	6,380	4,650	4,470	3,720	
	-25	-1	0	-12					
50	+42	+42	+14	+14	7,180	5,350	5,030	4,280	
	-1	-1	-12	-12					

- 1) ISO 4762-8.8 fastening bolts.
- 2) In relation to Ø d.
- 3) The load ratings apply for the main load direction. If the load direction is not the main load direction, the load ratings must be multiplied by the following factors.

Ø d 12 and 16: $f = 0.90, f_0 = 0.86$

Ø d 20 to 50: $f = 0.79, f_0 = 0.68$

The dynamic load ratings are based on a total travel of 100,000 m.
When based on 50,000 m, the C values in the table are multiplied by 1.26.

eLINE and compact linear sets

eLINE linear sets, R1029
Tandem
Closed, normal or stainless

Design

- Two eLINE linear bushings
- Lightweight precision tandem housing (aluminum)
- Integrated wiper seals
- **Reduced radial clearance**
- Initial lubrication with Dynalub 510
- Also available in stainless steel under KBC-NR



Compact linear sets, R1029
Tandem
Closed, normal or stainless

Design

- Two compact linear bushings
- Lightweight precision tandem housing (aluminum)
- Integrated wiper seals
- **Normal radial clearance**
- Initial lubrication with Dynalub 510
- Also available in stainless steel under KBC-NR

Shaft Ø d (mm)	Material number with eLINE linear set		Weight (kg)
	Reduced radial clearance, prelubricated		
	Normal LSACT-...-DD-RT-G	Stainless LSACT-...-DD-RT-NR-G	
12	R1029 251 44	R1029 251 34	0.17
16	R1029 252 44	R1029 252 34	0.24
20	R1029 253 44	R1029 253 34	0.31
25	R1029 254 44	R1029 254 34	0.57
30	R1029 255 44	R1029 255 34	0.80
40	R1029 256 44	R1029 256 34	1.54

Shaft Ø d (mm)	Material number with compact linear set		Weight (kg)
	Prelubricated		
	Normal LSACT-...-DD-G	Stainless LSACT-...-DD-NR-G	
12	R1029 212 44	R1029 212 34	0.17
16	R1029 216 44	R1029 216 34	0.24
20	R1029 220 44	R1029 220 34	0.31
25	R1029 225 44	R1029 225 34	0.57
30	R1029 230 44	R1029 230 34	0.80
40	R1029 240 44	R1029 240 34	1.54
50	R1029 250 44	R1029 250 34	2.45

Explanation of sample short product name

LS	A	C	T	12	DD	RT	NR	G
Linear set	Aluminum	Compact	Tandem	Ø 12	With two seals	Reduced radial clearance	Stainless steel	Greased

See page 28 for more information on short product names.

Dimensions

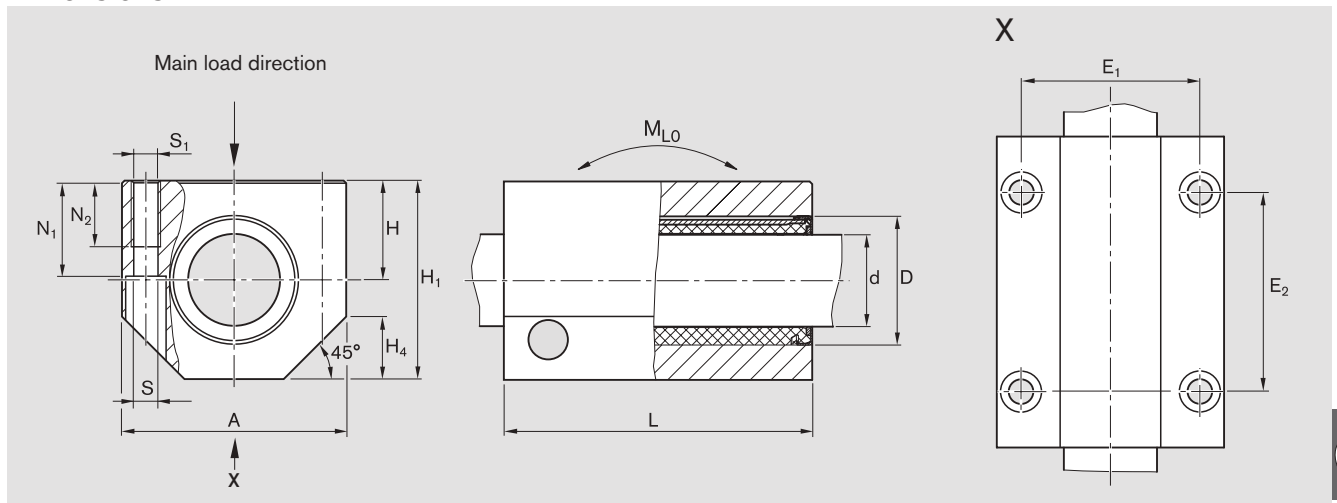

Dimensions (mm)

$\varnothing d$	D	H	H ₁	A	L	E ₁ ±0.15	E ₂ ±0.15	S ¹⁾	S ₁	N ₁	N ₂	H ₄
12	19	17	33	40	60	29	35	4.3	M5	16	11	11
16	24	19	38	45	65	34	40	4.3	M5	18	11	13
20	28	23	45	53	65	40	45	5.3	M6	22	13	15
25	35	27	54	62	85	48	55	6.6	M8	26	18	17
30	40	30	60	67	105	53	70	6.6	M8	29	18	19
40	52	39	76	87	125	69	85	8.4	M10	38	22	24
50	62	47	92	103	145	82	100	10.5	M12	46	26	30

$\varnothing d$ (mm)	Radial clearance (μm)		Tolerance for H ²⁾ (μm)	Load ratings ³⁾ (N)				Linear torque (Nm) stat. M _{Lo}
	Shaft			Normal		Stainless		
	R1029 eLINE h6	R1029 Compact h6		dyn. C	stat. C ₀	dyn. C	stat. C ₀	
12	+8 -24	+32 0	+24 0	1,310	980	920	780	13
16	+8 -24	+32 0	+24 0	1,700	1,140	1,180	920	18
20	+9 -25	+33 -1	+25 0	2,290	1,800	1,610	1,440	21
25	+12 -24	+36 0	+25 0	4,760	3,900	3,330	3,120	59
30	+12 -24	+36 0	+25 0	6,250	5,580	4,385	4,460	103
40	+18 -25	+42 -1	+26 0	10,360	9,300	7,260	7,440	204
50		+42 -1	+14 -12	11,660	10,700	8,170	8,560	271

- 1) ISO 4762-8.8 fastening bolts.
- 2) In relation to $\varnothing d$.
- 3) The load ratings apply for the main load direction. If the load direction is not the main load direction, the load ratings must be multiplied by the following factors.

$\varnothing d$ 12 and 16: $f = 0.90, f_0 = 0.86$

$\varnothing d$ 20 to 50: $f = 0.79, f_0 = 0.68$

The dynamic load ratings are based on a total travel of 100,000 m.
When based on 50,000 m, the C values in the table are multiplied by 1.26.

Super linear bushings **A** and **B**

Product overview

The benefits

- Low-cost linear bushing for high requirements
- Steel bearing plates with machined ball guide grooves and optimized ball lead-in chamfers for unmatched smooth travel and long service life
- Super linear bushing **A** compensates for shaft deflection and misalignment.
- Super linear bushing **B** without misalignment compensation for transferring lower pitching torque along the axial direction
- High travel speed (up to 5 m/s)
- Integrated wiper seals, top wiper seals or no wiper seals
- Open linear bushing on fully supported shafts for applications where other linear guides tend to warp due to imprecise substructures.
- Optional linear seal for open linear bushing
- Linear sets with aluminum or cast iron housing

Super linear bushings **A** and **B**

Optional misalignment compensation

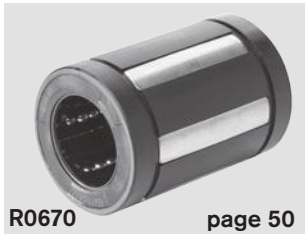
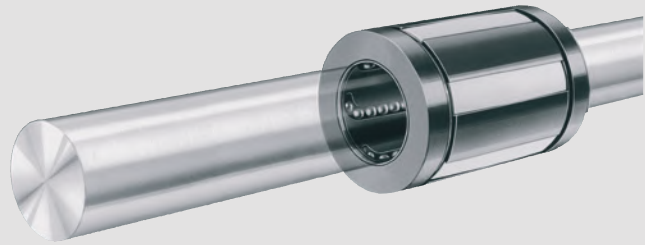

R0670 page 50

Super **A** (closed)

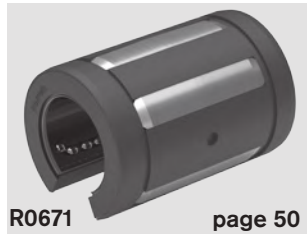

R0671 page 50

Super **A** (open)



R0672 page 52

Super **B** (closed)



R0673 page 52

Super **B** (open)

Explanation of short product name

Sample linear bushing:

Super linear bushing **A**



KBA-O-20-DD



Definition of codes			KB	A	O	20	DD
Type	Linear bushing	=	KB				
Series	Super A (with misalignment compensation)	=		A			
	Super B (no misalignment compensation)	=		B			
Form	Closed	=			O		
	Open	=				O	
Shaft diameter		=				20	
Seals	Fully sealed	=					VD
	With two seals	=					DD
	1 seal	=					D
	No seals	=					



Sample linear set:

Linear set with super linear bushing 
LSA-OE-B-20-DD-NR

Definition of codes		LS	A	O	E	B	20	DD
Type	Linear set =	LS						
Material (housing) (linear set only)	Aluminum =	A						
	Cast iron =	G						
	Steel =	S						
	Form	Closed =		O				
	Open =			O				
	Side opening =			S				
	Adjustable =			E				
	Flanged =			F				
	Tandem =			T				
Series	Super  (with misalignment compensation) =	A						
	Super  (no misalignment compensation) =	B						
Shaft diameter	=					20		
Seals	With two seals =							DD
	No seals =							

Super linear bushings  and 

Technical data

Please observe general technical principles and follow the lubricating and installation instructions.

Seal

Super linear bushings come both with integrated and separate wiper seals. The separate wiper seals are specially designed for high contamination environments. An additional seal (e.g., boot, extendable cover) is necessary for extremely high contamination environments. The open super linear bushings can also come fully sealed (with linear seal), however this increases friction.

Friction

The friction coefficients μ of the unsealed super linear bushings are 0.001 – 0.0025 when lubricated with oil. The friction coefficient is lowest under high load. It can also be greater than the indicated value under low loads. The table shows the friction generated by super linear bushings with integrated wiper seals on both ends when not under radial load. They depend on speed and lubrication.

Shaft $\varnothing d$ (mm)	Closed and open with integrated wiper seals		Open, fully sealed	
	Breakaway force ¹⁾ Reference value (N)	Friction ¹⁾ Reference value (N)	Breakaway force Reference value (N)	Friction Reference value (N)
10	1.0	0.5	–	–
12	1.5	0.8	6	3
16	2.0	1.0	9	4
20	3.0	1.5	10	5
25	4.5	2.0	14	6
30	6.0	2.5	18	8
40	8.0	3.0	24	10
50	10.0	4.0	30	12

1) When separate wiper seals are used, the values must be multiplied by 1.5.

Speed

$$v_{\max} = 3 \text{ m/s}$$

Speeds up to 5 m/s possible. Service life is limited by increased wear to plastic parts. Tests have shown total travel from 50 to 100 x 10⁵ m without failure.

Acceleration

$$a_{\max} = 150 \text{ m/s}^2$$

Operating temperature

-10 °C to 80 °C

Effect of load direction

On the load rating of closed super linear bushings

Depending on installation, the listed load ratings should be chosen at the minimum or maximum position and should be based on the calculations.

If the load direction is clearly defined and the super linear bushings can be installed at the maximum position, the load ratings C_{\max} (dynamic load rating) and $C_{0\max}$ (static load rating) can be used.

If directed installation is not possible or the load direction is not defined, the minimum load ratings must be used.

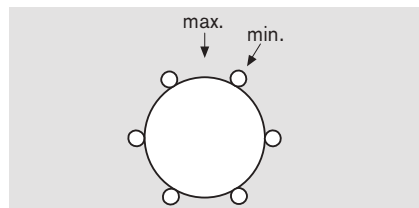

On the load rating of open super linear bushings

The load ratings C and C_0 apply for the main load direction $\varrho = 0^\circ$. For all other load directions, the load ratings must be multiplied by the factors f_ϱ (dynamic load rating) or $f_{\varrho 0}$ (static load rating C_0).

Installing specific super linear bushings can prevent a reduction in load rating (see linear set with side opening).

Load direction factors

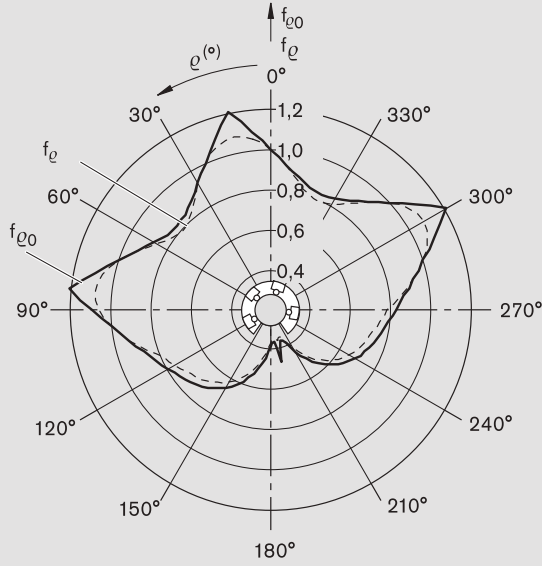

Shaft diameter 12

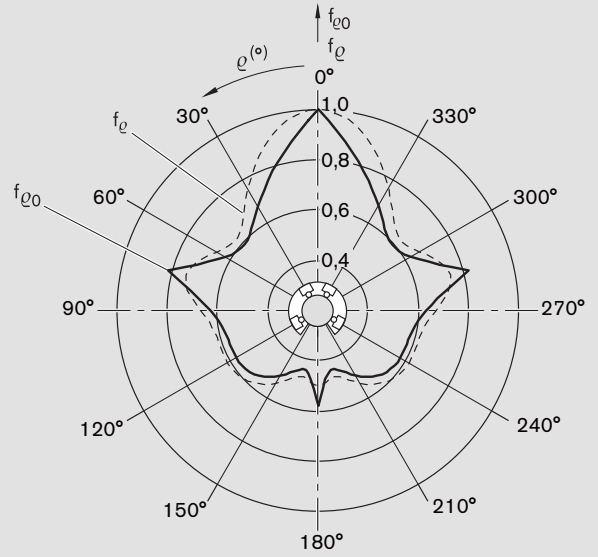

Shaft diameter 16

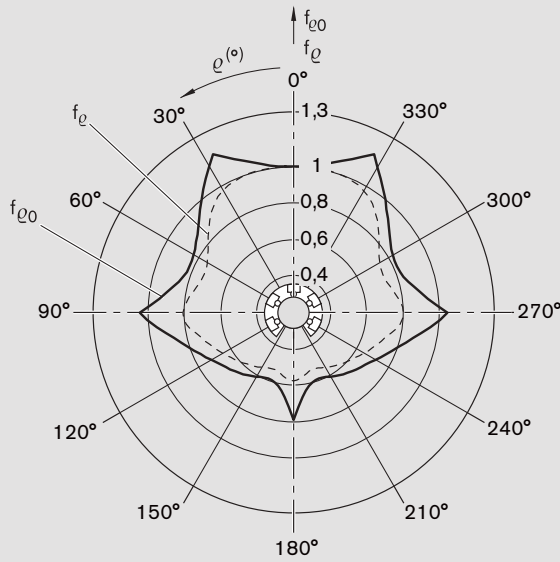

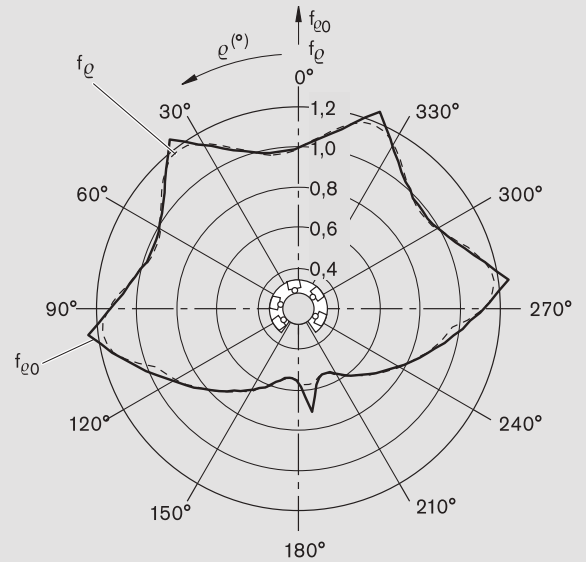

Shaft diameters 20 and 25



Shaft diameters 30 to 50



Super linear bushings  and 

Technical data

Reduced load rating with short stroke

When short stroke is present, the service life of the shaft is less than that of the super linear bushing.

The load ratings C in the tables must therefore be multiplied by the factor f_s .

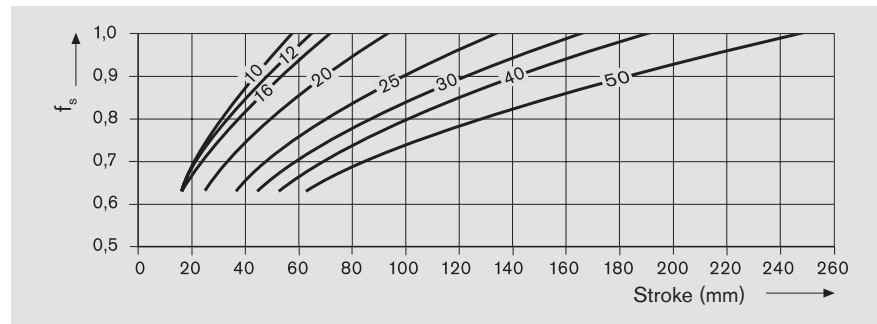

Reduced load rating with heavy load

If the load F on a super linear bushing  is more than $0.5 \times C$, the dynamic load rating C decreases.

Super linear bushing misalignment compensation

The misalignment compensation in the steel bearing plates and machined ball guide grooves ensure quieter travel. The flow chart shows a comparison with a conventional linear bushing. The example is based on a load of 800 N and a misalignment of about 8 ft (caused by shaft deflection).

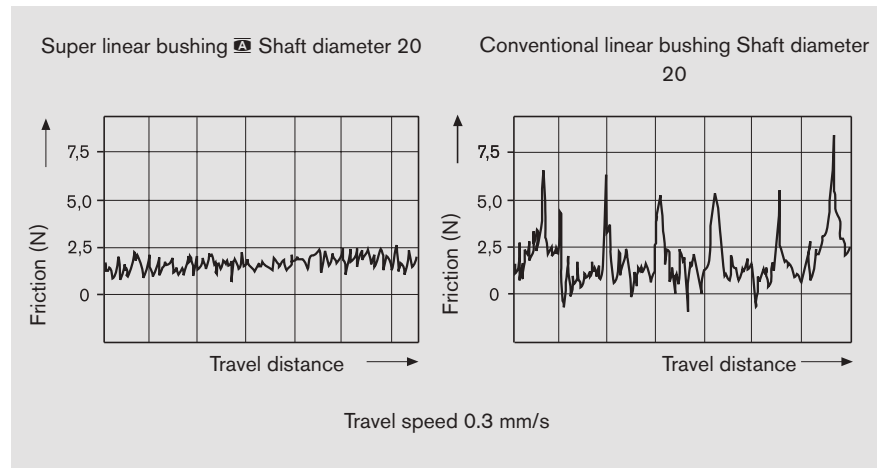
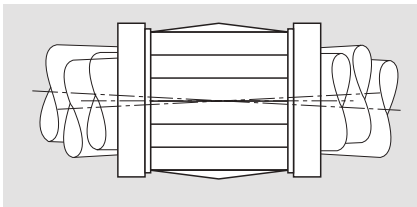

Due to misalignment compensation, two super linear bushings must be used on at least one of the shafts in the guide.

Operating under difficult conditions

We recommend the following linear bushing models for applications with water-based coolants/lubricants:

– Standard linear bushings

For constantly humid or damp conditions (steam, condensation), we recommend the following corrosion-resistant linear bushing models with stainless steel parts in accordance with ISO683-17/EN 10088:

- Segmental linear bushing (stainless)
- eLINE linear bushing (stainless)
- Compact linear bushing (stainless)
- Standard linear bushing (stainless)

Installation

Radial clearance

The radial clearance values shown in the table have been determined from statistics and correspond to values expected in practice.

Adjusting radial clearance



The radial clearance of all linear bushings can be adjusted. If, e.g., a zero-clearance guide is needed, the radial clearance of the linear bushing must be reduced using the adjusting screw on the housing (see also linear sets) until there is slight resistance when rotating the shaft.

Secure the adjusting screw for applications where vibrations are present.

Adjusting preload

For preloading, the aforementioned adjustment is made using an adjustment shaft that is weaker by the degree of preload.

Initial lubrication

Super linear bushings  and  do not come with initial lubrication. Grease linear bushings before use, see "Initial lubrication" Section "Lubrication" on page 21. Service life data is based on initial lubrication and relubricated linear bushings.

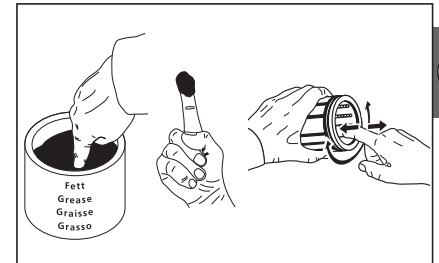

Super linear bushings **A** and **B**

Customer-built housings

Recommended tolerance for housing bore D:

- H7 Clearance, for all normal applications
 K7 Minimal clearance, for applications with alternating loads
 M7 Moderate preload, for applications with vibrations or high acceleration
 Please note the radial clearances (shaft/bore) in each of the tables.

Lubrication groove and lubricating hole for super linear bushings **A**, **B**, closed, with top wiper seals

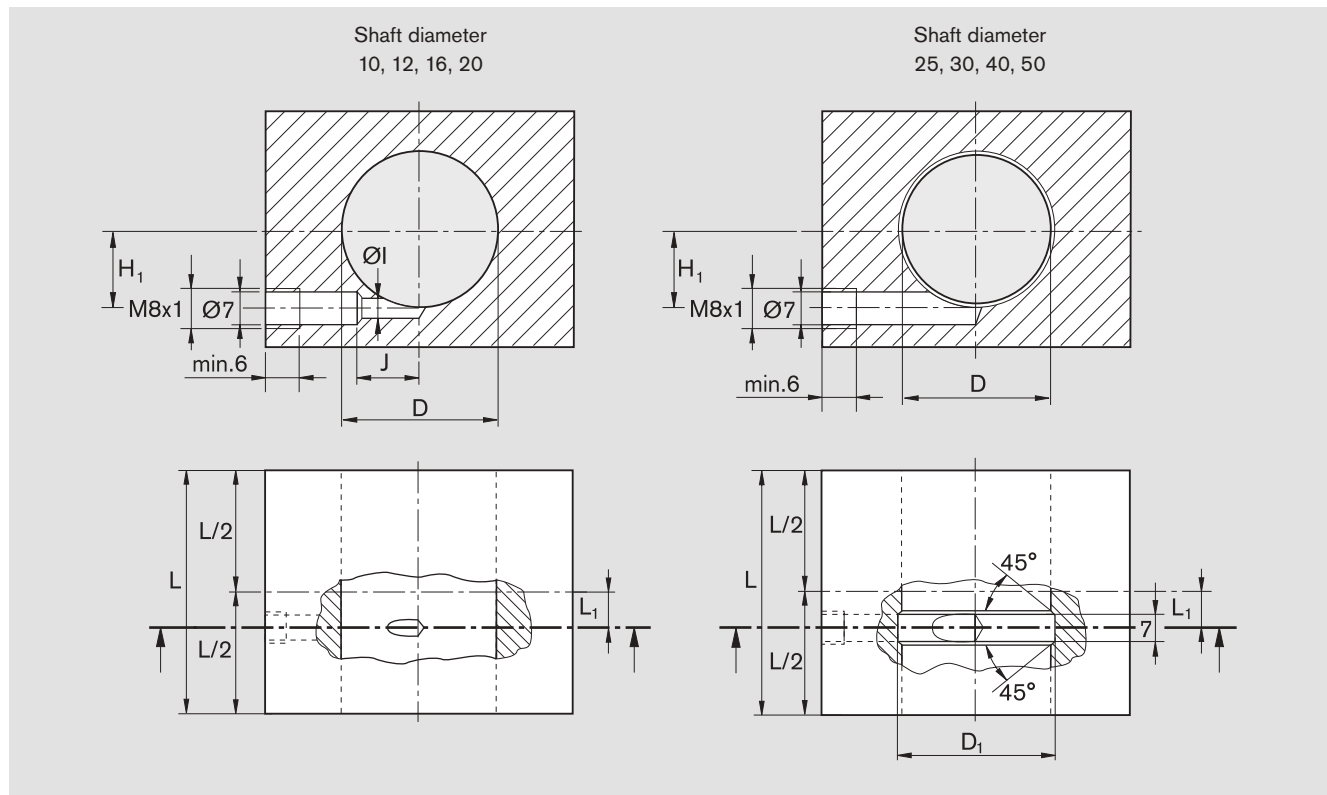

The lubricating channels shown are designed for grease, see Section "Lubrication" on page 21.

Material number			Shaft Ø d (mm)	Lubricant qty. ¹⁾ (cm ³)		Dimensions (mm)						
Super linear bushings		Wiper seals		Prelubrica- tion	Relubrica- tion	L ₁	H ₁	L (min)	D	D ₁	Ø I	J
A	B											
R0670 010 00	R0672 010 00	R1331 610 00	10	1.3	0.4	7.5	6.0	36	19	-	3	11.5
R0670 012 00	R0672 012 00	R1331 612 00	12	1.6	0.5	9.0	8.0	39	22	-	5	13.0
R0670 016 00	R0672 016 00	R1331 616 00	16	1.6	0.5	10.0	12.0	43	26	-	5	18.0
R0670 020 00	R0672 020 00	R1331 620 00	20	3.5	1.1	13.5	15.0	54	32	-	2	15.5
R0670 025 00	R0672 025 00	R1331 625 00	25	5.5	1.7	18.5	20.0	67	40	42	-	-
R0670 030 00	R0672 030 00	R1331 630 00	30	8.0	2.4	23.5	23.5	79	47	49	-	-
R0670 040 00	R0672 040 00	R1331 640 00	40	14.0	4.2	27.5	31.0	91	62	66	-	-
R0670 050 00	R0672 050 00	R1331 650 00	50	24.0	7.2	34.5	37.5	113	75	79	-	-

1) Max. fill volume for Rexroth linear bushings **in housing**.

2) The specified initial lubrication and relubrication fill volumes refer to the linear sets R1035/R1036.

Customer-built housings with other lube port dimensions will affect the fill volumes for initial lubrication.

Securing

Super linear bushings, closed

- Retaining rings
- Metal case
- Wiper seal with metal case
- Special design

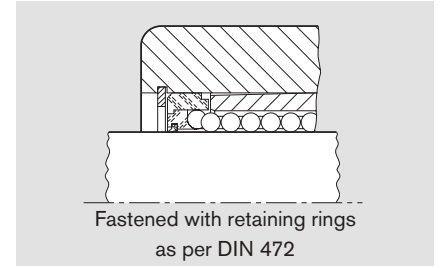
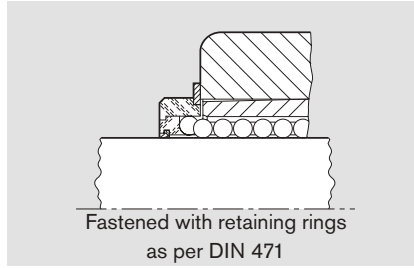

Shaft Ø d (mm)	DIN 471 retaining rings		DIN 472 retaining rings	
	Material number	Dimensions (mm)	Material number	Dimensions (mm)
10	R3410 763 00	19x1.2	R3410 221 00	19x1
12	R3410 714 00	22x1.2	R3410 209 00	22x1
16	R3410 715 00	27x1.2 ¹⁾	R3410 210 00	26x1.2
20	R3410 716 00	33x1.5 ¹⁾	R3410 211 00	32x1.2
25	R3410 717 00	42x1.75	R3410 212 00	40x1.75
30	R3410 718 00	48x1.75	R3410 213 00	47x1.75
40	R3410 719 00	62x2	R3410 214 00	62x2
50	R3410 720 00	75x2.5	R3410 215 00	75x2.5

1) Not in accordance with DIN 471.

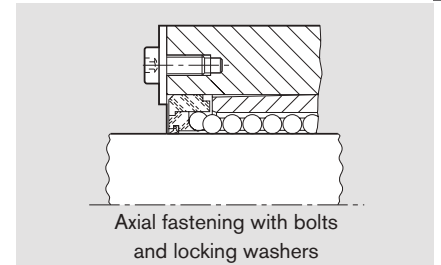
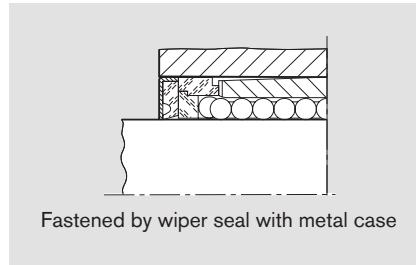
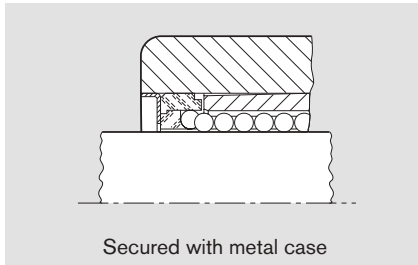

Wiper seals, closed

Design:

- Galvanized metal case
- Elastomer wiper seal

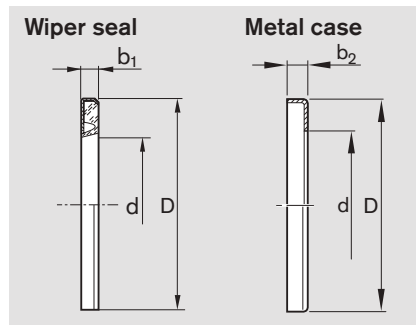

Closed metal case

Material: Galvanized steel



Shaft Ø d (mm)	Dimensions (mm)			Wiper seals		Metal cases	
	D ²⁾	b ₁ +0.3	b ₂ +0.5	Material number	Weight (g)	Material number	Weight (g)
10	19	3	3	R1331 610 00	1.1	R0901 184 00	0.64
12	22	3	3	R1331 612 00	1.6	R0901 074 00	0.94
16	26	3	3	R1331 616 00	2.0	R0901 075 00	1.20
20	32	4	4	R1331 620 00	4.5	R0901 076 00	3.00
25	40	4	4	R1331 625 00	6.6	R0901 077 00	4.20
30	47	5	5	R1331 630 00	9.3	R0901 078 00	5.30
40	62	5	5	R1331 640 00	17.0	R0901 079 00	9.20
50	75	6	6	R1331 650 00	24.0	R0901 115 00	13.60

2) Outer diameter D is oversized by about 0.1 mm. No additional securing is needed.

Super linear bushings **A** and **B**

Customer-built housings

Recommended tolerance for housing bore D:

H7 Clearance, for all normal applications
 K7 Minimal clearance, for applications with alternating loads
 M7 Moderate preload, for applications with vibrations or high acceleration
 Please note the radial clearances (shaft/bore) in each of the tables.

Lubrication groove and lubricating hole for super linear bushings **A**, **B**, open, with top wiper seals

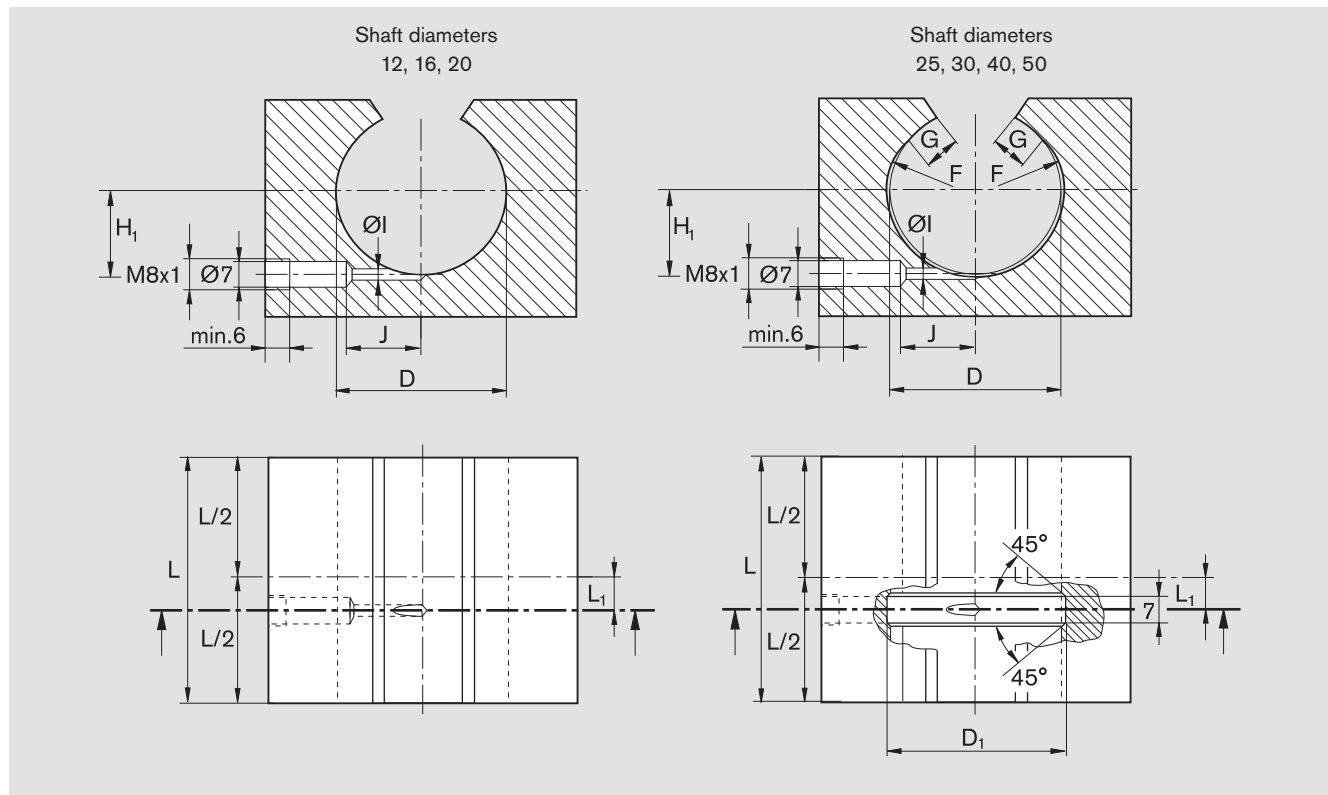

The lubricating channels shown are designed for grease, see Section "Lubrication" on page 21. Secure the wiper seals along the axis.

Material number Super linear bushings		Wiper seals	Shaft Ø d (mm)	Lubricant qty. ¹⁾ (cm ³)		Dimensions (mm)								
A	B			Prelubri- cation	Relubrication	L ₁	H ₁	L (min)	D	D ₁	F	G	Ø I	J
R0671 012 00	R0673 012 00	R1331 712 50	12	1.3	0.4	9.0	8.0	39	22	-	-	-	2	13
R0671 016 00	R0673 016 00	R1331 716 50	16	1.3	0.4	10.0	12.0	43	26	-	-	-	2	14
R0671 020 00	R0673 020 00	R1331 720 50	20	3.0	0.9	13.5	15.0	54	32	-	-	-	2	16
R0671 025 00	R0673 025 00	R1331 725 50	25	5.0	1.5	18.5	20.0	67	40	42	R15	4.0	7	-
R0671 030 00	R0673 030 00	R1331 730 50	30	7.0	2.1	23.5	23.5	79	47	49	R18	4.5	7	-
R0671 040 00	R0673 040 00	R1331 740 50	40	13.0	3.9	27.5	31.0	91	62	66	R23	6.0	7	-
R0671 050 00	R0673 050 00	R1331 750 50	50	22.0	6.6	34.5	37.5	113	75	79	R28	7.0	4	30

1) Max. fill volume for Rexroth linear bushings **in housing**.

The specified initial lubrication and relubrication fill volumes refer to the linear sets R1037/R1038.

Customer-built housings with other lube port dimensions will affect the fill volumes for initial lubrication.

Securing

Super linear bushings, open

- Axial and torsional fastening with grooved taper pin.

Note on installation:

Open super linear bushings come with the necessary locating hole indicated with a star  for shaft diameters 25 and higher. The taper pin is inserted to the specified depth during installation. The outer diameter of the super linear bushing is then constricted until it can slide past the pin. When aligning the linear bushing in the housing, the taper pin slides into the locating hole.

Mounting hole for taper pin in housing:

Shaft diameters 12 to 40:
 Ø 3.0 H11
 (ISO 8744 size 3 standard taper pin)



Shaft diameter 50:
 Ø 5.0 H11
 (ISO 8744 size 5 standard taper pin)

Super linear bushings for shaft diameters 25 to 50 have 2 locating holes.

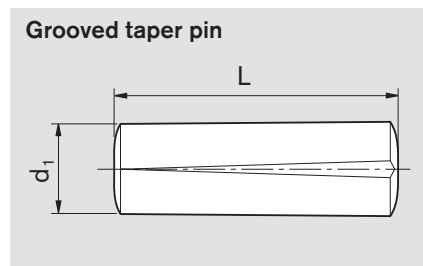
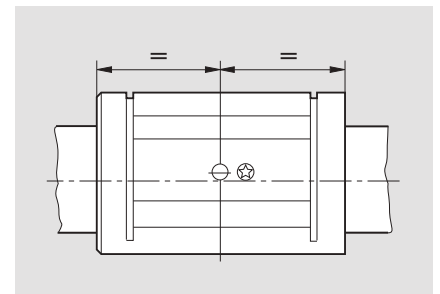
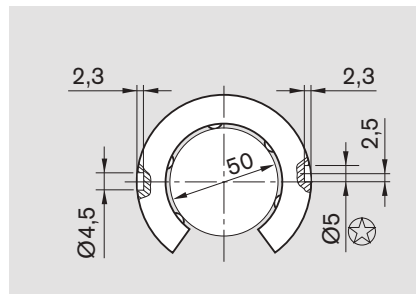
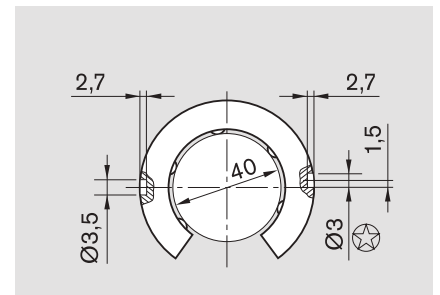
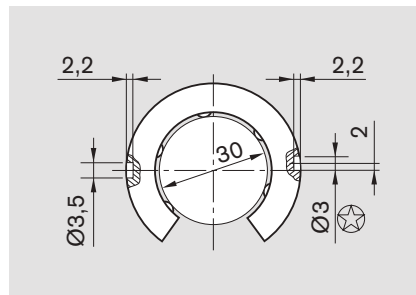
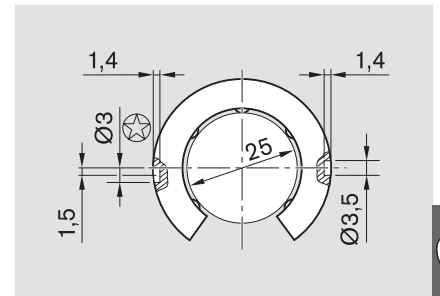
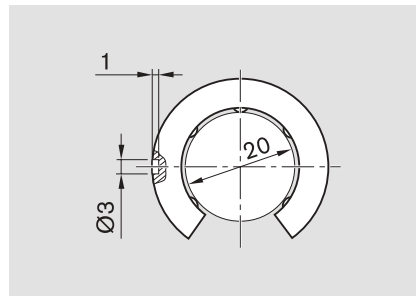
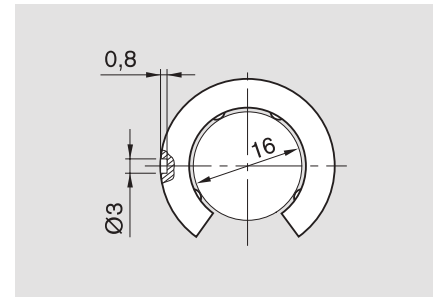
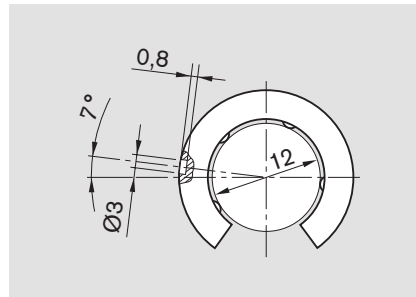
The second locating hole (Ø 3.5 for shaft diameters 25, 30 and 40, and Ø 4.5 for shaft diameter 50) can also be used to secure the linear bushing.



Shaft Ø d (mm)	Dimensions (mm)		Weight (g)	Mounting hole for taper pin (mm)	Material number Grooved taper pin
	d ₁	L			
12 ... 40	3	8.2	0.5	Ø 3 H11	R3425 013 00
	3	10.2	0.6		R3425 014 00
	3	14.2	0.8		R3425 015 00
50	5	20.4	3.1	Ø 5 H11	R3425 016 00
	5	14.0	2.2		R3425 017 00

Super linear bushings  and 

Customer-built housings

Securing

- Axial and torsional fastening with locating pin

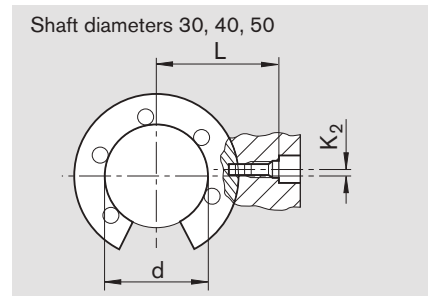
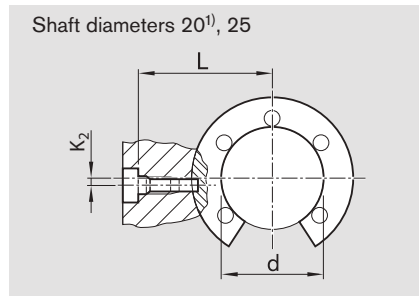
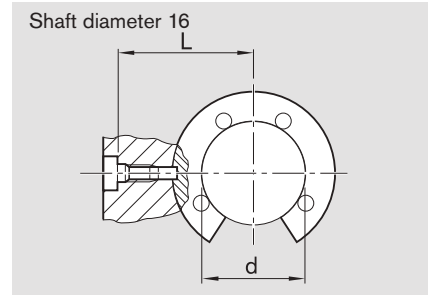
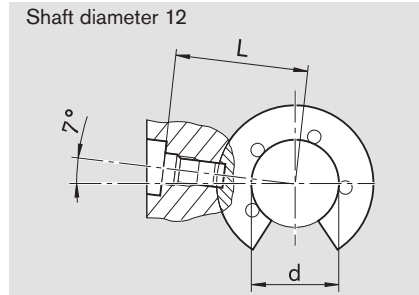

1) $K_2 = 0$ mm

Note on installation:

Open super linear bushings come with the necessary locating hole indicated with a star  for shaft diameters 25 and higher. During installation, the locating hole in the linear bushing is aligned with the pin hole in the housing. The pin is then screwed in and tightened to the specified torque.

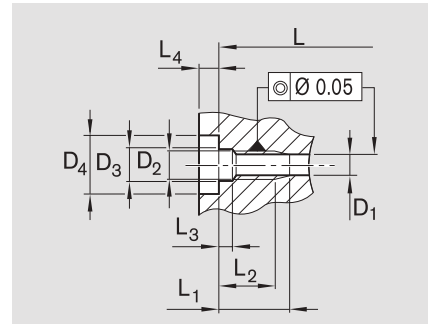
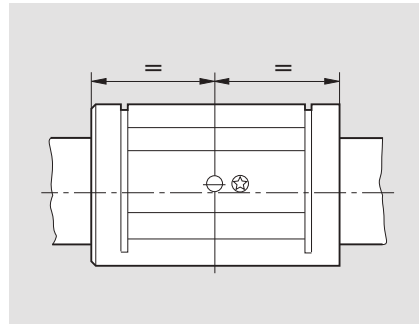

Locating screws

Locating screws are self-locking.

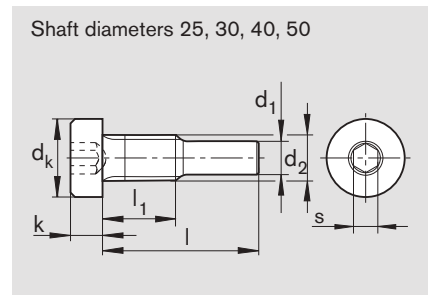
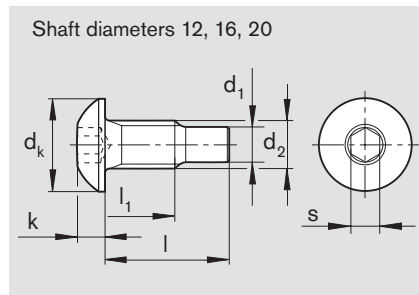

Dimensions (mm)																			Weight	Locating screw	
Shaft Ø d	L	K ₂	L ₁	L ₂ min.	L ₃ +0.2	L ₄ min.	D ₁ +0.1	D ₂	D ₃ H13	D ₄ H13	d ₂	d _k	d ₁	l	l ₁	k	s	(g)	Material number	Tightening torque (Nm)	
12	18.80 _{-0.10}	-	7.2 _{max}	5.2	1.3	2.5	3.1	M4	4.5	8	M4	7.6	3	8.45	4.5	2.2	2.5	1.3	R3429 008 01	1.9	
16	22.50 _{-0.10}	0	8.5 ^{+0.2}	6.5	1.3	2.5	3.1	M4	4.5	8	M4	7.6	3	10.15	5.7	2.2	2.5	1.4	R3429 009 01	1.9	
20	25.50 _{-0.10}	0	8.5 ^{+0.2}	6.5	1.3	2.5	3.1	M4	4.5	8	M4	7.6	3	10.15	5.7	2.2	2.5	1.4	R3429 009 01	1.9	
25	33.05 _{-0.10}	1.5	10.0 ^{+0.2}	8.0	2.0	3.2	3.1	M4	4.5	8	M4	7.0	3	14.10	6.5	2.8	2.5	1.8	R3427 009 09	1.9	
30	36.00 _{-0.15}	2.0	10.0 ^{+0.2}	8.0	2.0	3.2	3.1	M4	4.5	8	M4	7.0	3	14.10	6.5	2.8	2.5	1.8	R3427 009 09	1.9	
40	42.90 _{-0.15}	1.5	10.0 ^{+0.2}	8.0	2.0	3.2	3.1	M4	4.5	8	M4	7.0	3	14.10	6.5	2.8	2.5	1.8	R3427 009 09	1.9	
50	58.50 _{-0.20}	2.5	17.5 ^{+0.5}	13.5	3.7	6.0	5.1	M8	9.0	15	M8	13.0	5	22.80	12.5	5.0	5.0	11.1	R3427 005 09	16.0	

Wiper seals, open

Design:

- Galvanized metal case
- Elastomer wiper seal

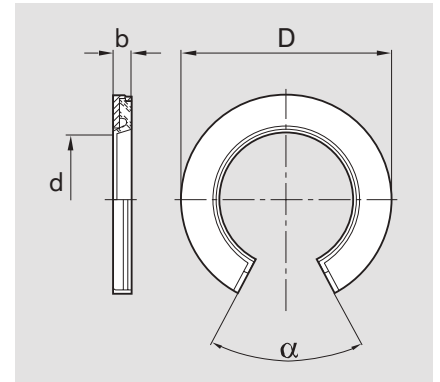

Dimensions (mm)		b +0.1 -0.2	Angle (°) $\alpha^{2)}$	Weight (g)	Material number Wiper seals
Shaft \varnothing d	D ¹⁾				
12	22	3	66	2.0	R1331 712 50
16	26	3	68	2.6	R1331 716 50
20	32	4	55	4.7	R1331 720 50
25	40	4	57	7.7	R1331 725 50
30	47	5	57	13.5	R1331 730 50
40	62	5	56	25.0	R1331 740 50
50	75	6	54	42.0	R1331 750 50

- 1) Outer diameter D is oversized by about 0.3 mm.
No additional securing is needed.
Additional fastening recommended for vibrations and high acceleration.
- 2) Minimum size installed; in a hole with nominal size "D".



Super linear bushings 

Super linear bushing with misalignment compensation

Super linear bushings, R0670 Closed

Super linear bushings, R0671 Open

Design

- Ball retainer and outer sleeve made of PA or POM
- Hardened steel bearing plates with machined ball guide grooves
- Balls made of rolling bearing steel
- Compensate for misalignments of up to 30 ft
- No wiper seal
- Integrated wiper seals
- No initial lubrication



Shaft Ø d (mm)	Material number		Weight (kg)
	No wiper seal KBA- ...	With two integrated wiper seals KBA- ... -DD	
10	R0670 010 00	R0670 210 40	0.017
12	R0670 012 00	R0670 212 40	0.023
16	R0670 016 00	R0670 216 40	0.028
20	R0670 020 00	R0670 220 40	0.061
25	R0670 025 00	R0670 225 40	0.122
30	R0670 030 00	R0670 230 40	0.185
40	R0670 040 00	R0670 240 40	0.360
50	R0670 050 00	R0670 250 40	0.580

With an integrated wiper seal: R0670 1 ... 40.

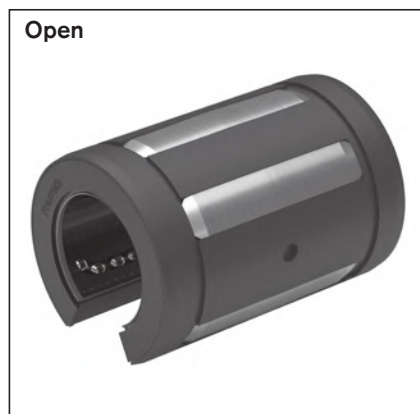

Shaft Ø d (mm)	Material number			Weight (kg)
	No wiper seal KBA-O- ...	with two integrated wiper seals KBA-O- ... -DD	with two integrated wiper seals and linear seal KBA-O- ... -VD	
12	R0671 012 00	R0671 212 40	R0671 212 45	0.018
16	R0671 016 00	R0671 216 40	R0671 216 45	0.022
20	R0671 020 00	R0671 220 40	R0671 220 45	0.051
25	R0671 025 00	R0671 225 40	R0671 225 45	0.102
30	R0671 030 00	R0671 230 40	R0671 230 45	0.155
40	R0671 040 00	R0671 240 40	R0671 240 45	0.300
50	R0671 050 00	R0671 250 40	R0671 250 45	0.480

With an integrated wiper seal: R0671 1 ... 40.

See Section "Customer-built housing" for separate wiper seals.

The dynamic load ratings are based on a total travel of 100,000 m.
When based on 50,000 m, the C values in the table are multiplied by 1.26.

Explanation of sample short product name

KB	A	O	20	DD
Linear bushing	Super 	Open	Ø 20	Two seals

See page 38 for more information on short product names.

Dimensions

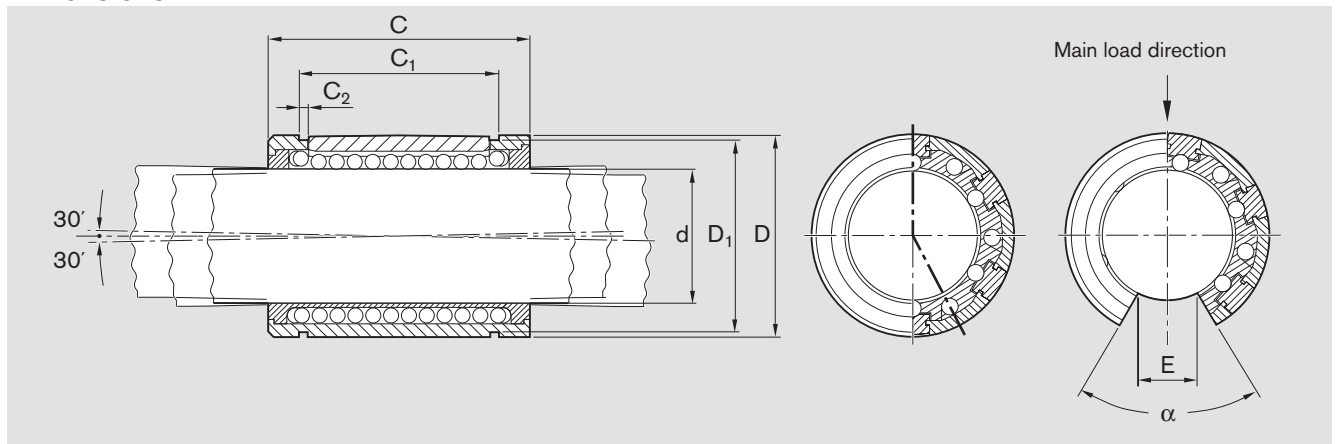

Closed

Dimensions (mm)						Rows of balls	Radial clearance (µm)			Load ratings (N)				
Ø d	D	C h13	C ₁ H13	C ₂	D ₁		Shaft/bore			min.	dyn. C		stat. C ₀	
							h6/H7	h6/K7	h6/M7		max.	min.	max.	
10	19	29	21.6	1.3	18.0	5	+9 +36	+21 -6	+15 -12	600	820	330	480	
12	22	32	22.6	1.3	21.0	5	+38 +10	+23 -5	+17 -11	830	1,140	420	620	
16	26	36	24.6	1.3	24.9	5	+38 +10	+23 -5	+17 -11	1,020	1,400	530	780	
20	32	45	31.2	1.6	30.5	6	+43 +11	+25 -7	+18 -14	2,020	2,470	1,050	1,340	
25	40	58	43.7	1.85	38.5	6	+43 +11	+25 -7	+18 -14	3,950	4,820	2,180	2,790	
30	47	68	51.7	1.85	44.5	6	+43 +11	+25 -7	+18 -14	4,800	5,860	2,790	3,570	
40	62	80	60.3	2.15	58.5	6	+50 +12	+29 -9	+20 -18	8,240	10,070	4,350	5,570	
50	75	100	77.3	2.65	71.5	6	+50 +12	+29 -9	+20 -18	12,060	14,730	6,470	8,280	

Open

Dimensions (mm)						Angle α (°)	Rows of balls	Radial clearance (µm)			Load ratings ²⁾ (N)	
Ø d	D	C h13	C ₁ H13	C ₂	E ¹⁾			h6/H7	h6/K7	h6/M7	dyn. C	stat. C ₀
12	22	32	22.6	1.3	6.5	66	4	+38 +10	+23 -5	+17 -11	1,060	510
16	26	36	24.6	1.3	9.0	68	4	+38 +10	+23 -5	+17 -11	1,500	830
20	32	45	31.2	1.6	9.0	55	5	+43 +11	+25 -7	+18 -14	2,570	1,180
25	40	58	43.7	1.85	11.5	57	5	+43 +11	+25 -7	+18 -14	5,040	2,470
30	47	68	51.7	1.85	14.0	57	5	+43 +11	+25 -7	+18 -14	5,020	2,880
40	62	80	60.3	2.15	19.5	56	5	+50 +12	+29 -9	+20 -18	8,620	4,480
50	75	100	77.3	2.65	22.5	54	5	+50 +12	+29 -9	+20 -18	12,500	6,620

⚠ Refer to the diagrams on page 41 for load in the direction of opening.

- 1) Minimum size in relation to Ø d
- 2) The load ratings apply for the main load direction.

Super linear bushings 

Super linear bushing without misalignment compensation

Super linear bushings, R0672
Closed

Super linear bushings, R0673
Open

Design

- Ball retainer and outer sleeve made of PA or POM
- Hardened steel bearing plates with machined ball guide grooves
- Balls made of rolling bearing steel
- No wiper seal
- Integrated wiper seals
- No initial lubrication



Shaft Ø d (mm)	Material number		Weight (kg)
	No wiper seal KBB- ...	With two integrated wiper seals KBB- ... -DD	
10	R0672 010 00	R0672 210 40	0.017
12	R0672 012 00	R0672 212 40	0.023
16	R0672 016 00	R0672 216 40	0.028
20	R0672 020 00	R0672 220 40	0.061
25	R0672 025 00	R0672 225 40	0.122
30	R0672 030 00	R0672 230 40	0.185
40	R0672 040 00	R0672 240 40	0.360
50	R0672 050 00	R0672 250 40	0.580

With an integrated wiper seal: R0672 1 ... 40.



Shaft Ø d (mm)	Material number			Weight (kg)
	No wiper seal KBB-O- ...	With two integrated wiper seals KBB-O- ... -DD	With two integrated wiper seals and linear seal KBB-O- ... -VD	
12	R0673 012 00	R0673 212 40	R0673 212 45	0.018
16	R0673 016 00	R0673 216 40	R0673 216 45	0.022
20	R0673 020 00	R0673 220 40	R0673 220 45	0.051
25	R0673 025 00	R0673 225 40	R0673 225 45	0.102
30	R0673 030 00	R0673 230 40	R0673 230 45	0.155
40	R0673 040 00	R0673 240 40	R0673 240 45	0.300
50	R0673 050 00	R0673 250 40	R0673 250 45	0.480

With an integrated wiper seal: R0673 1 ... 40.

See Section "Customer-built housing" for separate wiper seals.

The dynamic load ratings are based on a total travel of 100,000 m.
When based on 50,000 m, the C values in the table are multiplied by 1.26.

Explanation of sample short product name

KB	B	O	20	DD
Linear bushing	Super 	Open	Ø 20	Two seals

See page 38 for more information on short product names.

Dimensions

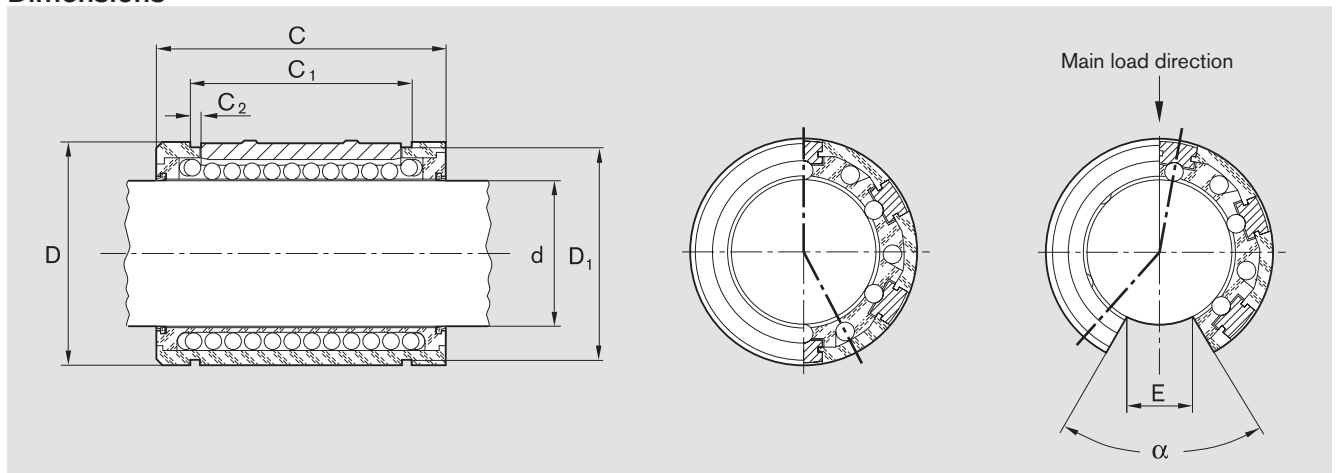

Closed

Dimensions (mm)						Rows of balls	Radial clearance (µm) Shaft/bore			Load ratings (N)			
Ø d	D	C h13	C ₁ H13	C ₂	D ₁		h6/H7	h6/K7	h6/M7	min.	dyn. C max.	min.	stat. C ₀ max.
10	19	29	21.6	1.3	18.0	5	+9 +36	+21 -6	+15 -12	600	820	330	480
12	22	32	22.6	1.3	21.0	5	+38 +10	+23 -5	+17 -11	830	1,140	420	620
16	26	36	24.6	1.3	24.9	5	+38 +10	+23 -5	+17 -11	1,020	1,400	530	780
20	32	45	31.2	1.6	30.5	6	+43 +11	+25 -7	+18 -14	2,020	2,470	1,050	1,340
25	40	58	43.7	1.85	38.5	6	+43 +11	+25 -7	+18 -14	3,950	4,820	2,180	2,790
30	47	68	51.7	1.85	44.5	6	+43 +11	+25 -7	+18 -14	4,800	5,860	2,790	3,570
40	62	80	60.3	2.15	58.5	6	+50 +12	+29 -9	+20 -18	8,240	10,070	4,350	5,570
50	75	100	77.3	2.65	71.5	6	+50 +12	+29 -9	+20 -18	12,060	14,730	6,470	8,280

Open



Dimensions (mm)						Angle α (°)	Rows of balls	Radial clearance (µm) Shaft/bore			Load ratings ²⁾ (N)	
Ø d	D	C h13	C ₁ H13	C ₂	E ¹⁾			h6/H7	h6/K7	h6/M7	dyn. C	stat. C ₀
12	22	32	22.6	1.3	6.5	66	4	+38 +10	+23 -5	+17 -11	1,060	510
16	26	36	24.6	1.3	9.0	68	4	+38 +10	+23 -5	+17 -11	1,500	830
20	32	45	31.2	1.6	9.0	55	5	+43 +11	+25 -7	+18 -14	2,570	1,180
25	40	58	43.7	1.85	11.5	57	5	+43 +11	+25 -7	+18 -14	5,040	2,770
30	47	68	51.7	1.85	14.0	57	5	+43 +11	+25 -7	+18 -14	5,020	2,880
40	62	80	60.3	2.15	19.5	56	5	+50 +12	+29 -9	+20 -18	8,620	4,480
50	75	100	77.3	2.65	22.5	54	5	+50 +12	+29 -9	+20 -18	12,500	6,620

⚠ Refer to the diagrams on page 41 for load in the direction of opening.

- 1) Minimum size in relation to Ø d
- 2) The load ratings apply for the main load direction.

Linear sets with super linear bushings  or 

Overview

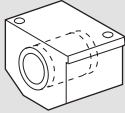
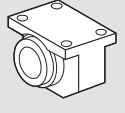
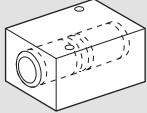
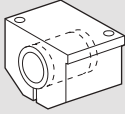
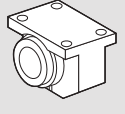
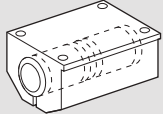
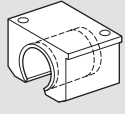
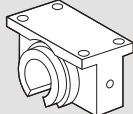
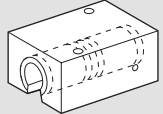
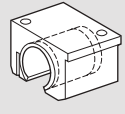
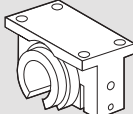
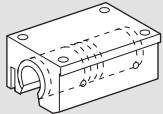
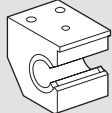
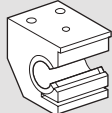
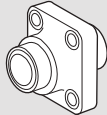
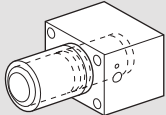
	Linear sets Super linear bushings  with misalignment compensation Super linear bushings  without misalignment compensation		Tandem linear sets Super linear bushings  with misalignment compensation
	Aluminum housing	Cast iron/steel housing	Aluminum housing
Closed For precision guides with easy installation. Fixed working bore diameter.	R1035 	R1065 	R1085 
Adjustable For zero-clearance or preloaded guides. Adjusting screw for adjusting radial clearance. These linear sets come set to zero clearance.	R1036 	R1066 	R1032 
Open For long guides requiring shaft support and high rigidity.	R1037 	R1067 	R1087 
Open, adjustable For zero-clearance or preloaded guides. Adjusting screw for adjusting radial clearance. These linear sets come set to zero clearance.	R1038 	R1068 	R1034 
Side opening For absorbing forces from all directions without reducing load rating.	R1071 		
Side opening, adjustable For zero-clearance or preloaded guides. Adjusting screw for adjusting radial clearance. These linear sets come set to zero clearance.	R1072 		
Flanged This modular unit complements the linear set series and is used for designs with a vertical shaft.		R1081 	R1083 

Benefits/installation

Benefits

High load rating and rigidity

These linear sets provide high rigidity regardless of load direction, even at maximum load.

Aluminum variant features compact block design and easy installation

The super linear bushing is completely enclosed in the compact housing and protected from external forces. The threads allow fastening from above or below. The reference edge of the housings allow it to be aligned with ease to prevent distortive stress on the linear bushings. Centering holes make additional bolting easier.

High precision and functional reliability

The housing design and the built-in super linear bushing guarantee high precision and functional reliability.

Zero-clearance guides

The adjustable linear bushings accommodate zero-clearance guides.

Operating temperatures

-10 °C to 80 °C

Installation

Radial clearance

The radial clearance values shown in the table have been determined from statistics and correspond to values expected in practice.

The adjustable linear sets come clamped to an h5 shaft (lower limit) and set to zero clearance.

Vertical dimension

The tolerance values for the vertical dimension "H" for linear sets shown in the table have been determined from statistics and correspond to values expected in practice.

Bolts

We recommend bolts in accordance with ISO 4762-8.8 for fastening the linear sets.

Lubrication

On-shaft relubrication only and until lubricant comes out.

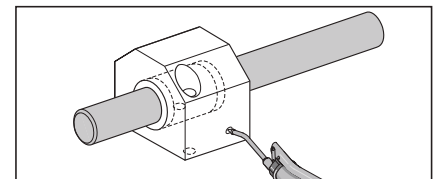

Notes on installing linear sets with side opening

No reference edges

- Straighten the first shaft using the shaft support rail and fasten it in place.
- Align the second shaft parallel to the first and fasten it in place.
- Slide the linear sets onto the shaft and fasten it to the machine table.

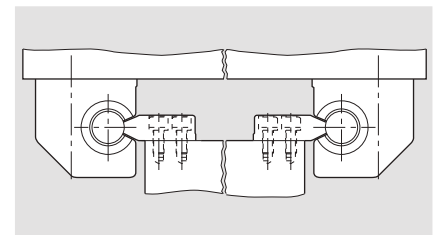

With reference edges

- Press the first shaft with shaft support rail onto the reference edge and fasten the shaft support rail in place.
- Align the second shaft parallel to the first and fasten the shaft support rail in place.
- Slide the linear sets onto the shafts.

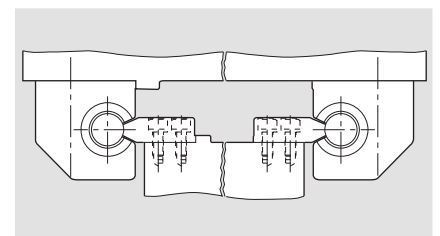



Next:

- a) With one reference edge on the machine base and one on the machine table: Press the linear sets on the first shaft onto the reference edge of the machine table and fasten it in place. Fasten the linear sets on the second shaft to the machine table.

- b) With just one reference edge on the machine base: Fasten linear sets to the machine table.



Linear sets with super linear bushings  or 

Linear sets, R1035 Closed

Linear sets, R1036 Adjustable

Design

- Lightweight precision housing (aluminum)
- Super linear bushing with or without misalignment compensation
- Top wiper seals
- Relubricatable



Shaft Ø d (mm)	Material number		Weight (kg)
	Super linear bushing  Relubricatable With two wiper seals LSA-A- ... -DD	Super linear bushing  Relubricatable With two wiper seals LSA-B- ... -DD	
10	R1035 610 20	R1035 810 20	0.10
12	R1035 612 20	R1035 812 20	0.13
16	R1035 616 20	R1035 816 20	0.20
20	R1035 620 20	R1035 820 20	0.34
25	R1035 625 20	R1035 825 20	0.65
30	R1035 630 20	R1035 830 20	0.97
40	R1035 640 20	R1035 840 20	1.80
50	R1035 650 20	R1035 850 20	3.00



Shaft Ø d (mm)	Material number		Weight (kg)
	Super linear bushing  Relubricatable With two wiper seals LSAE-A- ... -DD	Super linear bushing  Relubricatable With two wiper seals LSAE-B- ... -DD	
10	R1036 610 20	R1036 810 20	0.10
12	R1036 612 20	R1036 812 20	0.13
16	R1036 616 20	R1036 816 20	0.20
20	R1036 620 20	R1036 820 20	0.34
25	R1036 625 20	R1036 825 20	0.65
30	R1036 630 20	R1036 830 20	0.97
40	R1036 640 20	R1036 840 20	1.80
50	R1036 650 20	R1036 850 20	3.00

Explanation of sample short product name

LS	A	E	B	20	DD
Linear set	Aluminum	Adjustable	Super 	Ø 20	Two seals

See page 39 for more information on short product names.

Dimensions

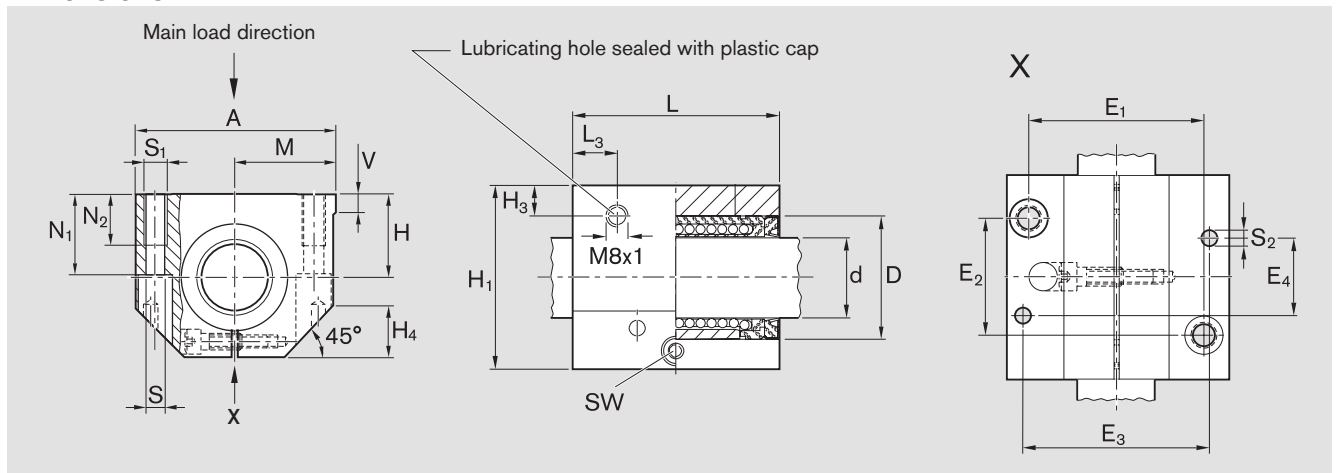

Dimensions (mm)

Δd	D	$H_1^{1)}$ +0.008 -0.016	H_1	$M^{1)}$ ± 0.01	A	L	E_1	E_2	E_3	E_4	$S^{2)}$	S_1	$S_2^{3)}$	N_1	N_2	H_3	L_3	V	SW	H_4
10	19	16	31.5	20.0	40	36	29 ± 0.15	20 ± 0.15	31	29	4.3	M5	4	15.0	11	10.0	10.5	5.0	2.5	10
12	22	18	35.0	21.5	43	39	32 ± 0.15	23 ± 0.15	34	32	4.3	M5	4	16.5	11	10.0	10.5	5.0	2.5	10
16	26	22	42.0	26.5	53	43	40 ± 0.15	26 ± 0.15	42	35	5.3	M6	4	21.0	13	10.0	11.5	5.0	3.0	13
20	32	25	50.0	30.0	60	54	45 ± 0.15	32 ± 0.15	50	45	6.6	M8	5	24.0	18	10.0	13.5	5.0	4.0	16
25	40	30	60.0	39.0	78	67	60 ± 0.15	40 ± 0.15	64	20	8.4	M10	6	29.0	22	10.0	15.0	6.5	5.0	20
30	47	35	70.0	43.5	87	79	68 ± 0.15	45 ± 0.15	72	30	8.4	M10	6	34.0	22	11.5	16.0	8.0	5.0	22
40	62	45	90.0	54.0	108	91	86 ± 0.15	58 ± 0.15	90	35	10.5	M12	8	44.0	26	14.0	18.0	10.0	6.0	28
50	75	50	105.0	66.0	132	113	108 ± 0.20	50 ± 0.20	108	42	13.5	M16	10	49.0	34	12.5	22.0	12.0	8.0	37

Δd (mm)	Radial clearance (μm)		Load ratings ⁴⁾ (N)	
	R1035 h6 shaft	R1036	dyn. C	stat. C ₀
10	+36 +9	Comes clamped to h5 shaft (lower limit) and set to zero clearance	730	380
12	+38 +10		1,020	490
16	+38 +10		1,250	620
20	+43 +11		2,470	1,340
25	+43 +11		4,820	2,790
30	+43 +11		5,860	3,570
40	+50 +12		10,070	5,570
50	+50 +12		14,730	8,280



- 1) Clamped (fastened) in relation to Δd .
- 2) ISO 4762-8.8 fastening bolts.
- 3) Pin centering.
- 4) The load ratings apply for the main load direction. If the load direction is not the main load direction, the load ratings must be multiplied by the following factors:

Δd 10 to 16: $f = 0.82, f_0 = 0.86$

Δd 20 to 50: $f = 0.82, f_0 = 0.78$

The dynamic load ratings are based on a total travel of 100,000 m. When based on 50,000 m, the C values in the table are multiplied by 1.26.



Linear sets with super linear bushings  or 



Linear sets, R1037 Open

Linear sets, R1038 Open



Design

- Lightweight precision housing (aluminum)
- Secured by grooved taper pin
- Super linear bushing with or without misalignment compensation
- Top wiper seals
- Relubricatable



Shaft Ø d (mm)	Material number		Weight (kg)
	Super linear bushing 	Super linear bushing 	
	Relubricatable With two wiper seals LSAO-A- ... -DD	Relubricatable With two wiper seals LSAO-B- ... -DD	
12	R1037 612 20	R1037 812 20	0.11
16	R1037 616 20	R1037 816 20	0.17
20	R1037 620 20	R1037 820 20	0.30
25	R1037 625 20	R1037 825 20	0.57
30	R1037 630 20	R1037 830 20	0.86
40	R1037 640 20	R1037 840 20	1.60
50	R1037 650 20	R1037 850 20	2.60



Shaft Ø d (mm)	Material number		Weight (kg)
	Super linear bushing 	Super linear bushing 	
	Relubricatable With two wiper seals LSAOE-A- ... -DD	Relubricatable With two wiper seals LSAOE-B- ... -DD	
12	R1038 612 20	R1038 812 20	0.11
16	R1038 616 20	R1038 816 20	0.17
20	R1038 620 20	R1038 820 20	0.30
25	R1038 625 20	R1038 825 20	0.57
30	R1038 630 20	R1038 830 20	0.86
40	R1038 640 20	R1038 840 20	1.60
50	R1038 650 20	R1038 850 20	2.60

Explanation of sample short product name

LS	A	O	E	B	20	DD
Linear set	Aluminum	Open	Adjustable	Super 	Ø 20	Two seals

See page 39 for more information on short product names.

Dimensions

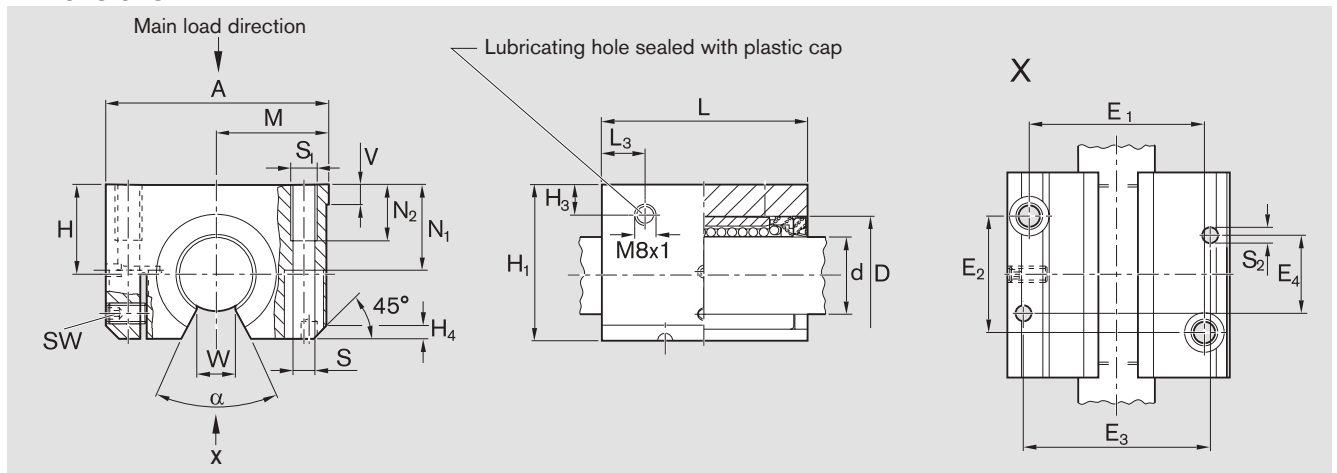

Dimensions (mm)

Ø d	D	H ¹⁾ +0.008 -0.016	H ₁	M ¹⁾ ±0.01	A	L	E ₁	E ₂	E ₃	E ₄	S ²⁾	S ₁	S ₂ ³⁾	N ₁	N ₂	H ₃	L ₃	V	SW	W ⁴⁾	H ₄
12	22	18	28	21.5	43	39	32±0.15	23±0.15	34	32	4.3	M5	4	16.5	11	10.0	10.5	5.0	2.5	6.5	1.5
16	26	22	35	26.5	53	43	40±0.15	26±0.15	42	35	5.3	M6	4	21.0	13	10.0	11.5	5.0	2.5	9.0	2.5
20	32	25	42	30.0	60	54	45±0.15	32±0.15	50	45	6.6	M8	5	24.0	18	10.0	13.5	5.0	2.5	9.0	3.5
25	40	30	51	39.0	78	67	60±0.15	40±0.15	64	20	8.4	M10	6	29.0	22	10.0	15.0	6.5	3.0	11.5	4.0
30	47	35	60	43.5	87	79	68±0.15	45±0.15	72	30	8.4	M10	6	34.0	22	11.5	16.0	8.0	3.0	14.0	6.0
40	62	45	77	54.0	108	91	86±0.15	58±0.15	90	35	10.5	M12	8	44.0	26	14.0	18.0	10.0	4.0	19.5	6.0
50	75	50	88	66.0	132	113	108±0.20	50±0.20	108	42	13.5	M16	10	49.0	34	12.5	22.0	12.0	5.0	22.5	6.0

Ø d (mm)	Angle α (°)	Radial clearance ⁵⁾ (µm)		Load ratings ⁶⁾ (N)	
		R1037 h6 shaft	R1038	dyn. C	stat. C ₀
12	66	+28 -1	Comes clamped to h5 shaft (lower limit) and set to zero clearance	1,060	510
16	68	+28 -1		1,500	830
20	55	+31 -2		2,570	1,180
25	57	+31 -2		5,040	2,470
30	57	+31 -2		5,020	2,880
40	56	+35 -3		8,620	4,480
50	54	+35 -3		12,500	6,620

- 1) Clamped (fastened) in relation to Ø d.
- 2) ISO 4762-8.8 fastening bolts.
- 3) Pin centering.
- 4) Minimum size in relation to Ø d.
- 5) Clamped (fastened).
- 6) The load ratings apply for the main load direction.

The dynamic load ratings are based on a total travel of 100,000 m.
When based on 50,000 m, the C values in the table are multiplied by 1.26.

⚠ Refer to the diagrams on page 41 for load in the direction of opening.

Linear sets with super linear bushings  or 

Linear sets, R1071 Side opening



Linear sets, R1072 Side opening, adjustable

Design



- Lightweight precision housing (aluminum)
- Secured by grooved taper pin
- Super linear bushing with or without misalignment compensation
- Top wiper seals
- Relubricatable

Load exerted on the direction of opening of open linear bushings usually results in a considerable reduction in load rating. In order to prevent this and facilitate the installation of specific open linear bushings, the lightweight linear set with side opening was developed.



Shaft Ø d (mm)	Material number		Weight (kg)
	Super linear bushing  Relubricatable With two wiper seals LSAS-A- ... -DD	Super linear bushing  Relubricatable With two wiper seals LSAS-B- ... -DD	
20	R1071 620 20	R1071 820 20	0.42
25	R1071 625 20	R1071 825 20	0.80
30	R1071 630 20	R1071 830 20	1.20
40	R1071 640 20	R1071 840 20	2.00
50	R1071 650 20	R1071 850 20	3.20



Shaft Ø d (mm)	Material number		Weight (kg)
	Super linear bushing  Relubricatable With two wiper seals LSASE-A- ... -DD	Super linear bushing  Relubricatable With two wiper seals LSASE-B- ... -DD	
20	R1072 620 20	R1072 820 20	0.42
25	R1072 625 20	R1072 825 20	0.80
30	R1072 630 20	R1072 830 20	1.20
40	R1072 640 20	R1072 840 20	2.00
50	R1072 650 20	R1072 850 20	3.20

Explanation of sample short product name

LS	A	S	E	B	20	DD
Linear set	Aluminum	Side opening	Adjustable	Super 	Ø 20	Two seals

See page 39 for more information on short product names.

Dimensions

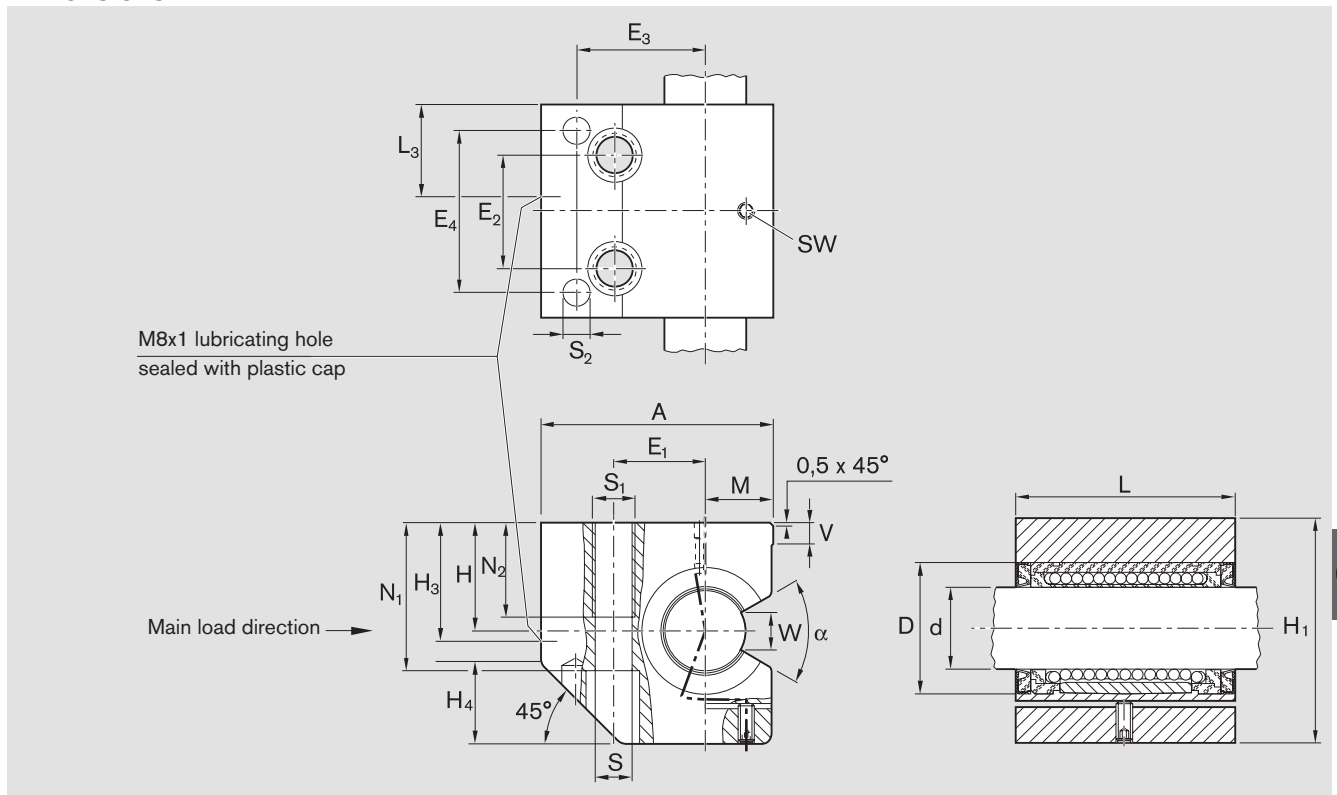

Dimensions (mm)																					
Ø d	D	H ¹⁾ +0.008 -0.016	H ₁	M ¹⁾ ±0.01	A	L	E ₁ ±0.15	E ₂ ±0.15	E ₃	E ₄	S ²⁾	S ₁	S ₂ ³⁾	N ₁	N ₂	V	SW	W ⁴⁾	H ₃	L ₃	H ₄
20	32	30	60	17	60	54	22	30	33	42	8.4	M10	6	42	15	5.0	2.5	9.0	32	23.5	22
25	40	35	72	21	75	67	28	36	42	52	10.5	M12	8	50	18	6.5	3.0	11.5	38	29.0	26
30	47	40	82	25	86	79	34	42	48	60	13.5	M16	10	55	24	8.0	3.0	14.0	44	34.0	30
40	62	45	100	32	110	91	43	48	62	68	15.5	M20	12	67	30	10.0	4.0	19.5	50	40.0	38
50	75	50	115	38	127	113	50	62	70	85	17.5	M20	12	78	30	12.0	5.0	22.5	56	48.0	45

Shaft Ø d (mm)	Angle α (°)	Radial clearance ⁵⁾ (µm)		Load ratings ⁶⁾ (N)	
		R1071 h6 shaft	R1072	dyn. C	stat. C ₀
20	55	+31 -2	Comes clamped to h5 shaft (lower limit) and set to zero clearance	2,570	1,180
25	57	+31 -2		5,040	2,470
30	57	+31 -2		5,020	2,880
40	56	+35 -3		8,620	4,480
50	54	+35 -3		12,500	6,620

- 1) Clamped (fastened) in relation to Ø d.
- 2) ISO 4762-8.8 fastening bolts.
- 3) Pin centering.
- 4) Minimum size in relation to Ø d.
- 5) Clamped (fastened).
- 6) The load ratings apply for the main load direction.

The dynamic load ratings are based on a total travel of 100,000 m.
When based on 50,000 m, the C values in the table are multiplied by 1.26.

See the notes on installing linear sets with side opening.

⚠ Refer to the diagrams on page 41 for load in the direction of opening.

Linear sets with super linear bushings , tandem

Linear sets, R1085 Closed

Linear sets, R1032 Adjustable

Design

- Lightweight precision tandem housing (aluminum)
- Two super linear bushings 
- Top wiper seals
- Reference edge (for tandem linear set, adjustable)
- Relubricatable



Shaft Ø d (mm)	Material number LSAT-A- ... -DD	Weight (kg)
12	R1085 612 20	0.27
16	R1085 616 20	0.41
20	R1085 620 20	0.72
25	R1085 625 20	1.35
30	R1085 630 20	2.01
40	R1085 640 20	3.67
50	R1085 650 20	6.30



Shaft Ø d (mm)	Material number LSATE-A- ... -DD	Weight (kg)
10	R1032 610 20	0.20
12	R1032 612 20	0.27
16	R1032 616 20	0.41
20	R1032 620 20	0.72
25	R1032 625 20	1.35
30	R1032 630 20	2.01
40	R1032 640 20	3.67
50	R1032 650 20	6.30

Also available as linear slides.
See R310 3001 in the "Linear slides"
catalog.

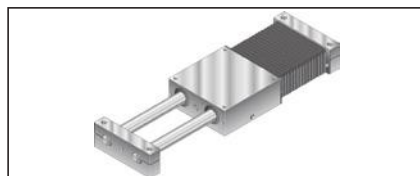

Explanation of sample short product name

LS	A	T	E	A	20	DD
Linear set	Aluminum	Tandem	Adjustable	Super 	Ø 20	Two seals

See page 39 for more information on short product names.

Dimensions

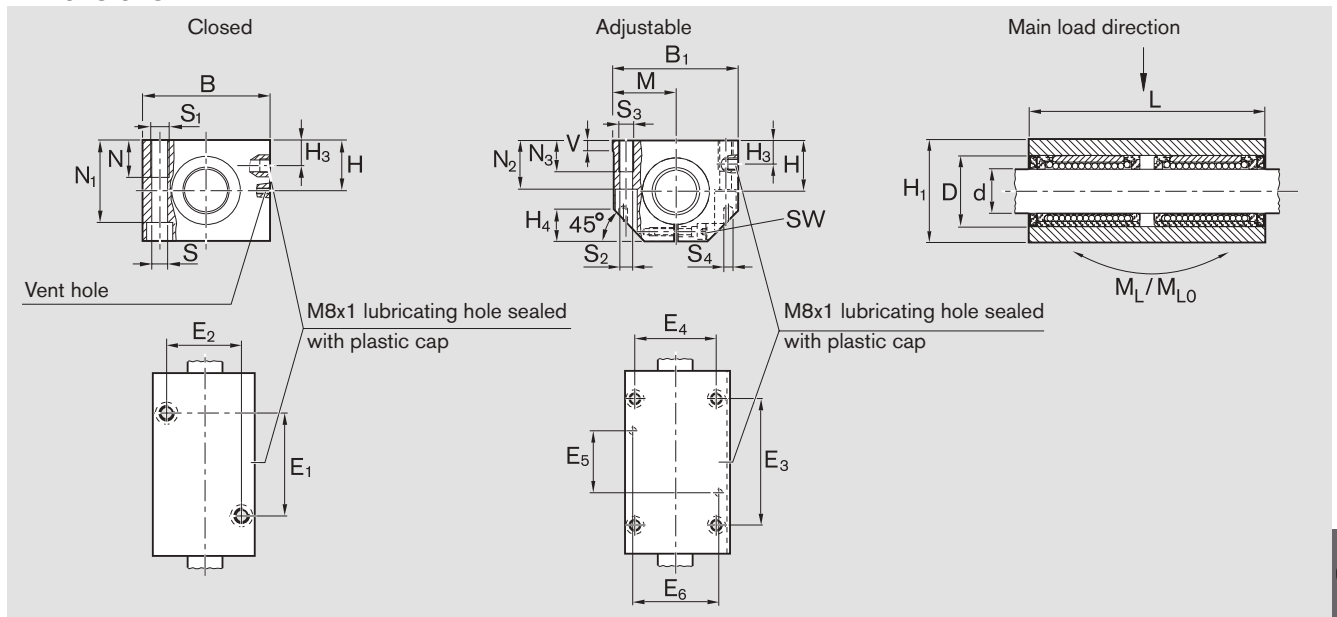

Dimensions (mm)

Ø d	D	H ¹⁾ +0.008 -0.016	H ₁	H ₃	M ¹⁾ ±0.01	B	B ₁	L	E ₁ ²⁾ ±0.15	E ₂ ²⁾ ±0.15	E ₃ ²⁾ ±0.15	E ₄ ²⁾ ±0.15	E ₅	E ₆	S ³⁾	S ₁	S ₂ ³⁾	S ₃	S ₄ ⁴⁾	N	N ₁	N ₂	N ₃	V	SW	H ₄
10	19	16	31.5	9	20.0	-	40	70	-	-	52	29	20	31	-	-	4.3	M5	4	-	-	15.0	11	5.0	2.5	10
12	22	18	35.0	10	21.5	42	43	76	40	30	56	32	24	34	5.3	M6	4.3	M5	4	13	28	16.5	11	5.0	2.5	10
16	26	22	42.0	12	26.5	50	53	84	45	36	64	40	28	42	5.3	M6	5.3	M6	4	13	35	21.0	13	5.0	3.0	13
20	32	25	50.0	13	30.0	60	60	104	55	45	76	45	32	50	6.6	M8	6.6	M8	5	18	41	24.0	18	5.0	4.0	16
25	40	30	60.0	15	39.0	74	78	130	70	54	94	60	42	64	8.4	M10	8.4	M10	6	22	49	29.0	22	6.5	5.0	20
30	47	35	70.0	16	43.5	84	87	152	85	62	106	68	52	72	10.5	M12	8.4	M10	6	26	56	34.0	22	8.0	5.0	22
40	62	45	90.0	20	54.0	108	108	176	100	80	124	86	60	90	13.5	M16	10.5	M12	8	34	74	44.0	26	10.0	6.0	28
50	75	50	105.0	20	66.0	130	132	224	125	100	160	108	80	108	13.5	M16	13.5	M16	10	34	89	49.0	35	12.0	8.0	37

Ø d (mm)	Radial clearance (µm)		Load ratings ⁵⁾ (N)		Linear torque (Nm)	
	R1085 h6 shaft	R1032	dyn. C	stat. C ₀	dyn. M _L	stat. M _{L0}
10	-	Comes clamped to h5 shaft (lower limit) and set to zero clearance	1,180	760	17	12
12	+38 +10		1,660	980	26	16
16	+38 +10		2,430	1,660	18	13
20	+43 +11		4,010	2,680	84	54
25	+43 +11		8,180	4,940	141	86
30	+43 +11		9,520	7,140	289	206
40	+50 +12		16,360	11,140	576	374
50	+50 +12		23,930	16,560	1,097	725

- 1) Clamped (fastened) in relation to Ø d.
- 2) Shaft diameter 50: Tolerance ±0.2
- 3) ISO 4762-8.8 fastening bolts.
- 4) Pin centering.
- 5) Load rating when both linear bushings are under equal load.
The load ratings apply for the main load direction.
If the load direction is not the main load direction, the load ratings must be multiplied by the following factors:

Ø d 10 to 16: $f = 0.82, f_0 = 0.86$

Ø d 20 to 50: $f = 0.82, f_0 = 0.78$

Note on lubricating R1085 linear sets:
Only lubricate on shaft and until lubricant comes out of vent hole.

The dynamic load ratings are based on a total travel of 100,000 m.
When based on 50,000 m, the C values in the table are multiplied by 1.26.

Linear sets with super linear bushings , tandem

Linear sets, R1087 Open

Linear sets, R1034 Open, adjustable

Design

- Lightweight precision tandem housing (aluminum)
- Two super linear bushings 
- Two top wiper seals
- Reference edge (for tandem linear set, open, adjustable)
- Relubricatable



Shaft Ø d (mm)	Material number LSATO-A- ... -DD	Weight (kg)
12	R1087 612 20	0.22
16	R1087 616 20	0.34
20	R1087 620 20	0.62
25	R1087 625 20	1.17
30	R1087 630 20	1.68
40	R1087 640 20	3.15
50	R1087 650 20	5.50



Shaft Ø d (mm)	Material number LSATOE-A-20-DD	Weight (kg)
12	R1034 612 20	0.22
16	R1034 616 20	0.34
20	R1034 620 20	0.62
25	R1034 625 20	1.17
30	R1034 630 20	1.68
40	R1034 640 20	3.15
50	R1034 650 20	5.50

Also available as linear slides.
See R310DE 3001 in the "Linear slides" catalog.

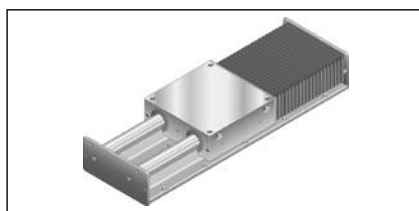

Explanation of sample short product name

LS	A	TO	E	A	20	DD
Linear set	Aluminum	Tandem, open	Adjustable	Super 	Ø 20	Two seals

See page 39 for more information on short product names.

Dimensions

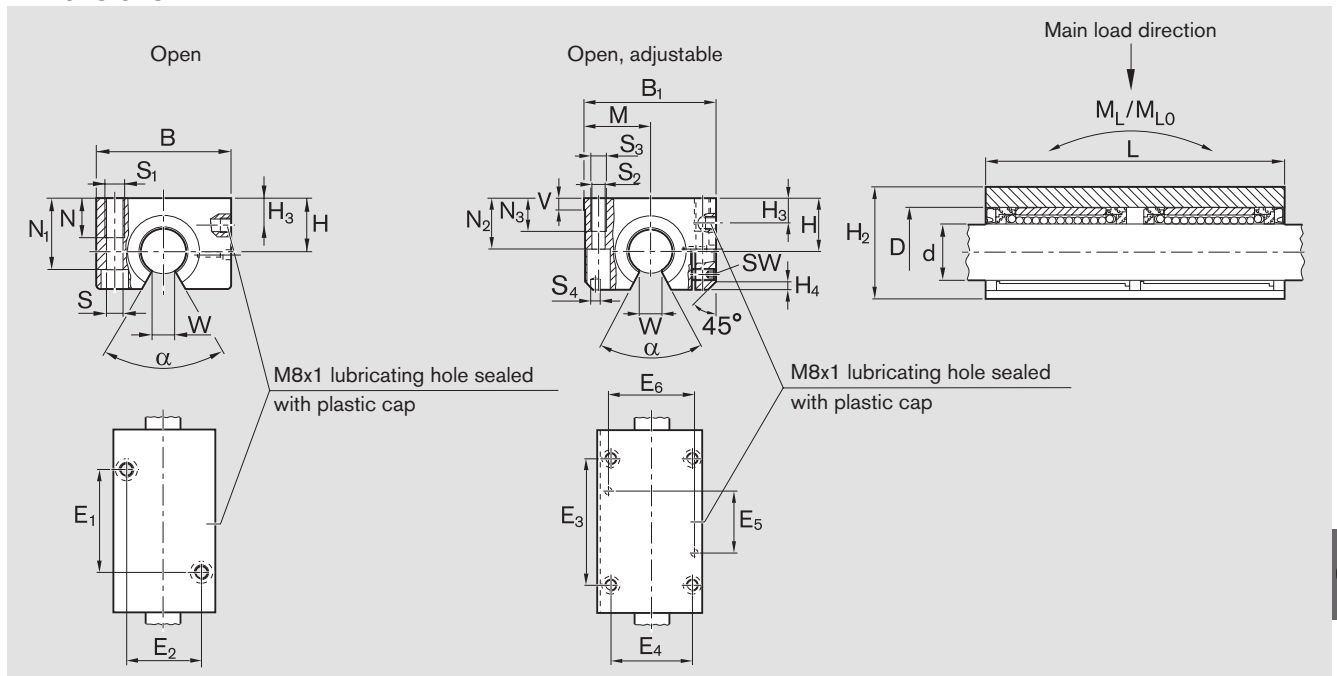

Dimensions (mm)																											
$\varnothing d$	D	H ²⁾ +0.008 -0.016	H ₂	H ₃	M ²⁾ ±0.01	B	B ₁	L	E ₁ ³⁾ ±0.15	E ₂ ³⁾ ±0.15	E ₃ ³⁾ ±0.15	E ₄ ³⁾ ±0.15	E ₅	E ₆	S ⁴⁾	S ₁	S ₂ ⁵⁾	S ₃	S ₄ ⁶⁾	N	N ₁	N ₂	N ₃	V	SW	W ⁷⁾	H ₄
12	22	18	30 ¹⁾	10	21.5	42	43	76	40	30	56	32	24	34	5.3	M6	4.3	M5	4	13	25	16.5	11	5.0	2.5	6.5	1.5
16	26	22	35	12	26.5	50	53	84	45	36	64	40	28	42	5.3	M6	5.3	M6	4	13	29.5	21.0	13	5.0	2.5	9.0	2.5
20	32	25	42	13	30.0	60	60	104	55	45	76	45	32	50	6.6	M8	6.6	M8	5	18	35.5	24.0	18	5.0	2.5	9.0	3.5
25	40	30	51	15	39.0	74	78	130	70	54	94	60	42	64	8.4	M10	8.4	M10	6	22	43.0	29.0	22	6.5	3.0	11.5	4.0
30	47	35	60	16	43.5	84	87	152	85	62	106	68	52	72	10.5	M12	8.4	M10	6	26	50.5	34.0	22	8.0	3.0	14.0	6.0
40	62	45	77	20	54.0	108	108	176	100	80	124	86	60	90	13.5	M16	10.5	M12	8	34	66.0	44.0	26	10	4.0	19.5	6.0
50	75	50	88	10	66.0	130	132	224	125	100	160	108	80	108	13.5	M16	13.5	M16	10	34	77.0	49.0	35	12	5.0	22.5	6.0

$\varnothing d$ (mm)	Angle α (°)	Radial clearance ⁸⁾ (μm)		Load ratings ⁹⁾ (N)		Linear torque (Nm)	
		R1087 h6 shaft	R1034	dyn. C	stat. C ₀	dyn. M _L	stat. M _{L0}
12	66	+28 -1	Comes clamped to h5 shaft (lower limit) and set to zero clearance	1,720	1,020	11	7
16	68	+28 -1		2,430	1,660	18	13
20	55	+31 -2		4,170	2,360	60	47
25	57	+31 -2		8,180	4,940	141	86
30	57	+31 -2		8,150	5,760	163	116
40	56	+35 -3		14,000	8,960	328	212
50	54	+35 -3		20,300	13,240	630	415

- 1) H₂ is 28 mm for an open, adjustable linear set.
- 2) Clamped (fastened) in relation to $\varnothing d$.
- 3) Shaft diameter 50: Tolerance ± 0.2
- 4) DIN 6912-8.8 fastening bolts.
- 5) ISO 4762-8.8 fastening bolts.
- 6) Pin centering.
- 7) Minimum size in relation to $\varnothing d$.
- 8) Clamped (fastened).
- 9) Load rating when both linear bushings are under equal load. The load ratings apply for the main load direction.

The dynamic load ratings are based on a total travel of 100,000 m.
When based on 50,000 m, the C values in the table are multiplied by 1.26.

⚠ Refer to the diagrams on page 41 for load in the direction of opening.

Linear sets with super linear bushings , tandem

Linear sets, R1083 Flanged

Design

- Precision lightweight flanged housing (aluminum)
- Two super linear bushings 
- Two top wiper seals
- Centering collar
- Thread for bolting from bottom area
- Relubricatable
- Radial clearance not adjustable



Shaft Ø d (mm)	Material number LSAFT-A- ... -DD	Weight (kg)
12	R1083 612 20	0.20
16	R1083 616 20	0.32
20	R1083 620 20	0.55
25	R1083 625 20	1.00
30	R1083 630 20	1.50

Explanation of sample short product name

LS	A	FT	A	20	DD
Linear set	Aluminum	Flanged, tandem	Super 	Ø 20	Two seals

See page 39 for more information on short product names.

Dimensions

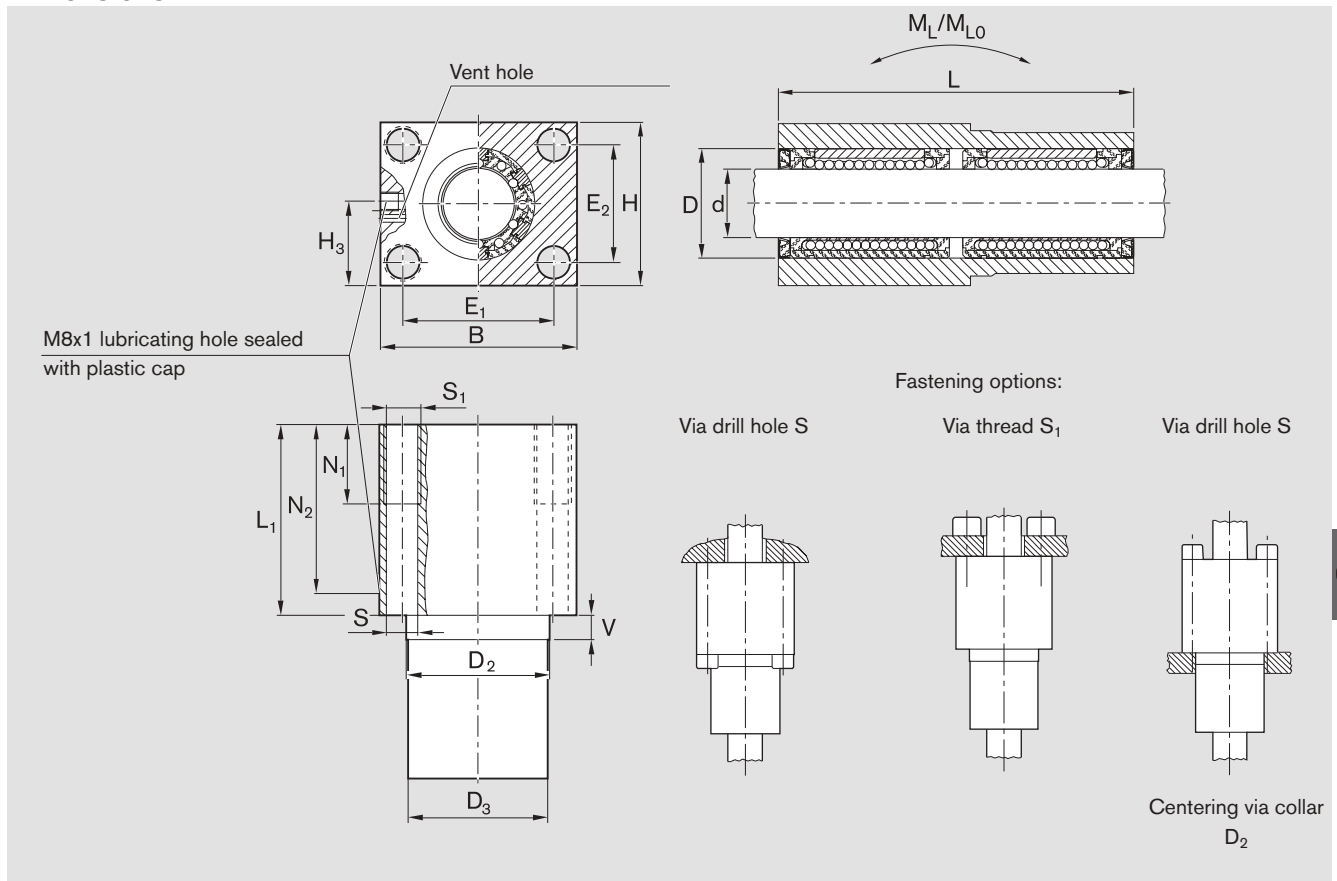

Dimensions (mm)																
$\varnothing d$	D	$D_2^{1)}$	D_3	H	H_3	B	L	L_1	E_1	E_2	$S^2)$	S_1	N_1	N_2	V	
12	22	30	30	34	19	42	76	46	32	24	5.3	M6	13	36	10	
16	26	35	35	40	22	50	84	50	38	28	6.6	M8	18	40	10	
20	32	42	42	50	27	60	104	60	45	35	8.4	M10	22	50	10	
25	40	52	52	60	32	74	130	73	56	42	10.5	M12	26	63	10	
30	47	61	61	70	37	84	152	82	64	50	13.5	M16	34	74	10	

Shaft $\varnothing d$ (mm)	Radial clearance (μm) h6 shaft	Load ratings ³⁾ (N)		Linear torque (Nm)	
		dyn. C	stat. C_0	dyn. M_L	stat. M_{L0}
12	+38 +10	1,350	840	26	16
16	+38 +10	1,660	1,060	35	22
20	+43 +11	3,280	2,100	84	54
25	+43 +11	6,420	4,360	205	140
30	+43 +11	7,800	5,580	289	206

- 1) Recommended installation: Mounting hole D_2^{H7} .
- 2) ISO 4762-8.8 fastening bolts.
- 3) Load rating when both linear bushings are under equal load.

Note on lubrication:
Only lubricate on shaft and until lubricant comes out of vent hole.

The dynamic load ratings are based on a total travel of 100,000 m.
When based on 50,000 m, the C values in the table are multiplied by 1.26.

Linear sets with super linear bushings  or 

Linear sets, R1065 Closed



Linear sets, R1066 Adjustable

Design

- Precision housing (cast iron/steel)
- Super linear bushing with or without misalignment compensation
- Integrated wiper seals



Closed



Shaft Ø d (mm)	Material number		Weight (kg)
	Super linear bushing  Integrated wiper seals LSG-A- ... -DD	Super linear bushing  Integrated wiper seals LSG-B- ... -DD	
12	R1065 612 40	R1065 812 40	0.15
16	R1065 616 40	R1065 816 40	0.24
20	R1065 620 40	R1065 820 40	0.42
25	R1065 625 40	R1065 825 40	0.83
30	R1065 630 40	R1065 830 40	1.22
40	R1065 640 40	R1065 840 40	2.29
50	R1065 650 40	R1065 850 40	3.23

Adjustable



Shaft Ø d (mm)	Material number		Weight (kg)
	Super linear bushing  Integrated wiper seals LSGE-A- ... -DD	Super linear bushing  Integrated wiper seals LSGE-B- ... -DD	
12	R1066 612 40	R1066 812 40	0.15
16	R1066 616 40	R1066 816 40	0.24
20	R1066 620 40	R1066 820 40	0.41
25	R1066 625 40	R1066 825 40	0.79
30	R1066 630 40	R1066 830 40	1.19
40	R1066 640 40	R1066 840 40	2.26
50	R1066 650 40	R1066 850 40	3.15

Explanation of sample short product name

LS	G	E	A	20	DD
Linear set	Cast iron	Adjustable	Super 	Ø 20	Two seals

See page 39 for more information on short product names.

Dimensions

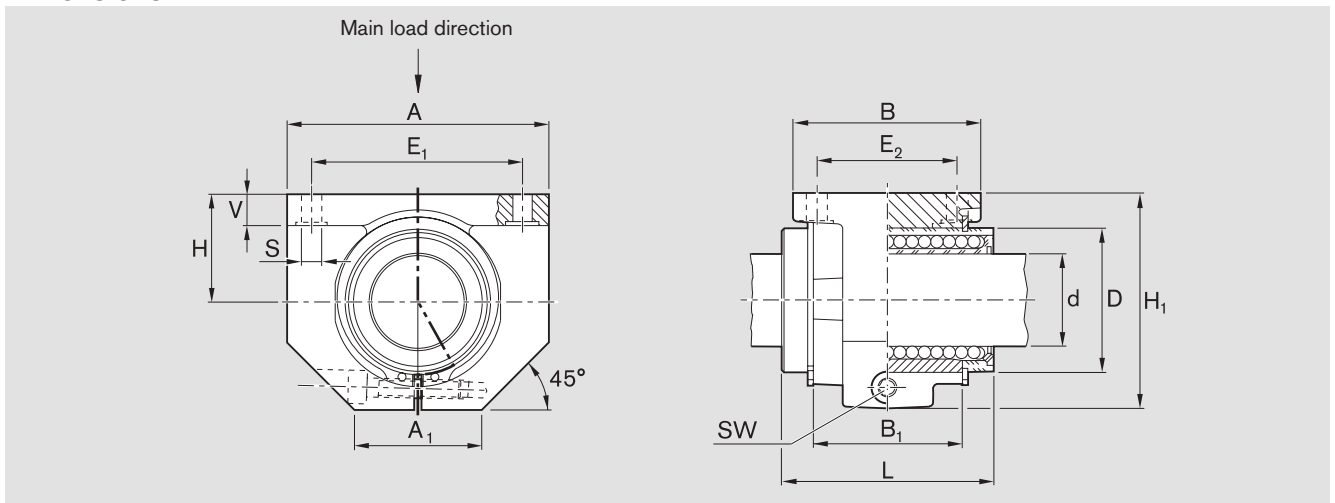

Dimensions (mm)														
Ø d	D	H	H ₁ ¹⁾	L	A ¹⁾	A ₁ ¹⁾	B ¹⁾	B ₁	E ₁	E ₂	S	V ¹⁾	SW	
12	22	18	35	32	42	21	32	20	32±0.15	23±0.15	4.5	5.5	2.5	
16	26	22	42	36	50	26	35	22	40±0.15	26±0.15	4.5	6.5	3.0	
20	32	25	50	45	60	28	42	28	45±0.15	32±0.15	4.5	8.0	3.0	
25	40	30	60	58	74	38	54	40	60±0.15	40±0.15	5.5	9.0	5.0	
30	47	35	70	68	84	41	60	48	68±0.20	45±0.20	6.6	10.0	5.0	
40	62	45	90	80	108	51	78	56	86±0.20	58±0.20	9.0	12.0	6.0	
50	75	50	105	100	130	57	70	72	108±0.20	50±0.20	9.0	14.0	8.0	

Shaft Ø d (mm)	Radial clearance (µm)		Tolerance for H ²⁾ (µm)	Load ratings ³⁾ (N)	
	R1065 h6 shaft	R1066		dyn. C	stat. C ₀
12	+38	Comes clamped to h5 shaft (lower limit) and set to zero clearance	+8	1,020	490
	+10		-16		
16	+38		+8	1,500	830
	+10		-16		
20	+43		+8	2,470	1,340
	+11		-16		
25	+43		+8	5,040	2,470
	+11		-16		
30	+43		+8	5,860	3,570
	+11		-16		
40	+50		+8	10,070	5,570
	+12		-16		
50	+50	+13	14,730	8,280	
	+12	-21			

- 1) ISO 8062-3 - DCTG 9 tolerance.
- 2) Clamped (fastened) in relation to Ø d.
- 3) The load ratings apply for the main load direction.
If the load direction is not the main load direction, the load ratings must be multiplied by the following factors:
Ø d 12 and 16: f = 0.82, f₀ = 0.86
Ø d 20 to 50: f = 0.82, f₀ = 0.78

The dynamic load ratings are based on a total travel of 100,000 m.
When based on 50,000 m, the C values in the table are multiplied by 1.26.

Linear sets with super linear bushings  or 



Linear sets, R1067 Open

Linear sets, R1068 Open, adjustable



Design

- Precision housing (spheroidal graphite cast iron/steel)
- Secured with locating screw
- Super linear bushing with or without misalignment compensation
- Integrated wiper seals



Shaft Ø d (mm)	Material number		Weight (kg)
	Super linear bushing  Integrated wiper seals LSGO-A- ... -DD	Super linear bushing  Integrated wiper seals LSGO-B- ... -DD	
12	R1067 612 40	R1067 812 40	0.13
16	R1067 616 40	R1067 816 40	0.20
20	R1067 620 40	R1067 820 40	0.36
25	R1067 625 40	R1067 825 40	0.70
30	R1067 630 40	R1067 830 40	1.05
40	R1067 640 40	R1067 840 40	2.05
50	R1067 650 40	R1067 850 40	2.77



Shaft Ø d (mm)	Material number		Weight (kg)
	Super linear bushing  Integrated wiper seals LSGOE-A- ... -DD	Super linear bushing  Integrated wiper seals LSGOE-B- ... -DD	
12	R1068 612 40	R1068 812 40	0.12
16	R1068 616 40	R1068 816 40	0.20
20	R1068 620 40	R1068 820 40	0.36
25	R1068 625 40	R1068 825 40	0.69
30	R1068 630 40	R1068 830 40	1.02
40	R1068 640 40	R1068 840 40	2.02
50	R1068 650 40	R1068 850 40	2.71

Explanation of sample short product name

LS	G	O	A	20	DD
Linear set	Cast iron	Open	Super 	Ø 20	Two seals

See page 39 for more information on short product names.

Dimensions

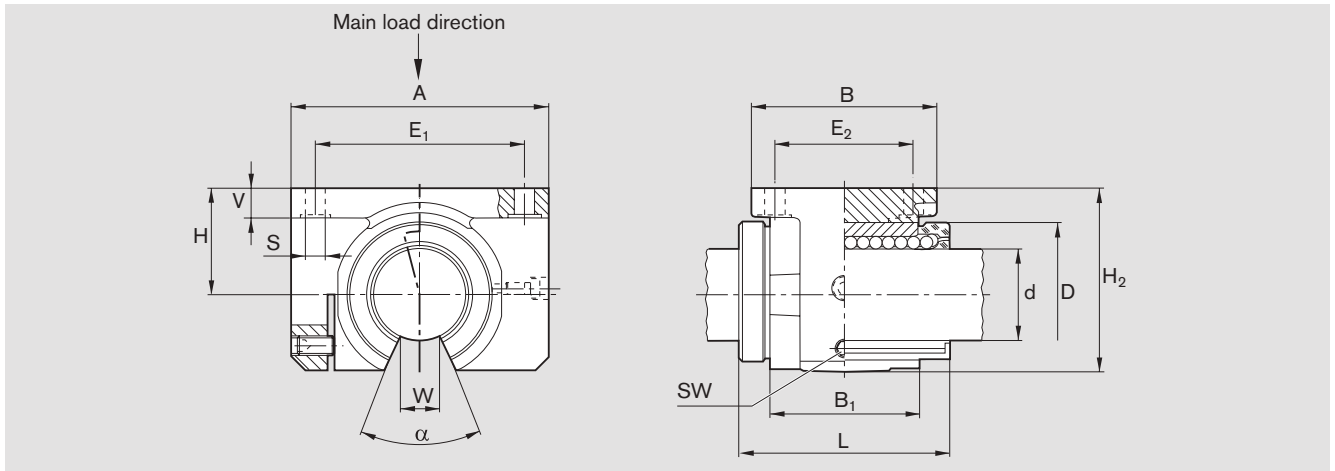

Dimensions (mm)													
Ø d	D	H	H ₂ ¹⁾	L	A ¹⁾	B ¹⁾	B ₁	E ₁	E ₂	S	V ¹⁾	W ²⁾	SW
12	22	18	28	32	42	32	20	32±0.15	23±0.15	4.5	5.5	6.5	2.5
16	26	22	35	36	50	35	22	40±0.15	26±0.15	4.5	6.5	9.0	2.5
20	32	25	42	45	60	42	28	45±0.15	32±0.15	4.5	8.0	9.0	2.5
25	40	30	51	58	74	54	40	60±0.15	40±0.15	5.5	9.0	11.5	3.0
30	47	35	60	68	84	60	48	68±0.20	45±0.20	6.6	10.0	14.0	3.0
40	62	45	77	80	108	78	56	86±0.20	58±0.20	9.0	12.0	19.5	4.0
50	75	50	88	100	130	70	72	108±0.20	50±0.20	9.0	14.0	22.5	5.0

Ø d (mm)	Angle α (°)	Radial clearance (µm)		Tolerance for H ³⁾ (µm)	Load ratings ⁴⁾ (N)	
		R1067 h6 shaft	R1068		dyn. C	stat. C ₀
12	66	+28 -1	Comes clamped to h5 shaft (lower limit) and set to zero clearance	+8 -16	1,060	510
16	68	+28 -1		+8 -16	1,280	630
20	55	+31 -2		+8 -16	2,570	1,180
25	57	+31 -2		+8 -16	5,040	2,470
30	57	+31 -2		+8 -16	5,020	2,880
40	56	+35 -3		+8 -16	8,620	4,480
50	54	+35 -3		+13 -21	12,500	6,620

- 1) ISO 8062-3 - DCTG 9 tolerance.
- 2) Minimum size in relation to Ø d.
- 3) Clamped (fastened) in relation to Ø d.
- 4) The load ratings apply for the main load direction.

The dynamic load ratings are based on a total travel of 100,000 m.
When based on 50,000 m, the C values in the table are multiplied by 1.26.

⚠ Refer to the diagrams on page 41 for load in the direction of opening.

Linear sets with super linear bushings **A** or **B**

Linear sets, R1081 Flanged

Design

- Precision flanged housing (lamellar graphite cast iron)
- Two retaining rings with additional two spacer rings (steel) for shaft diameters 12 to 40
- Super linear bushing with or without misalignment compensation
- Integrated wiper seals
- Radial clearance not adjustable
- No initial lubrication



Shaft Ø d (mm)	Material number		Weight (kg)
	Super linear bushing A with two wiper seals LSGF-A- ... -DD	Super linear bushing B with two wiper seals LSGF-B- ... -DD	
12	R1081 612 40	R1081 812 40	0.095
16	R1081 616 40	R1081 816 40	0.16
20	R1081 620 40	R1081 820 40	0.30
25	R1081 625 40	R1081 825 40	0.57
30	R1081 630 40	R1081 830 40	1.85
40	R1081 640 40	R1081 840 40	1.65
50	R1081 650 40	R1081 850 40	3.40

Explanation of sample short product name

LS	G	F	A	20	DD
Linear set	Cast iron	Flanged	Super A	Ø 20	Two seals

See page 39 for more information on short product names.

Dimensions

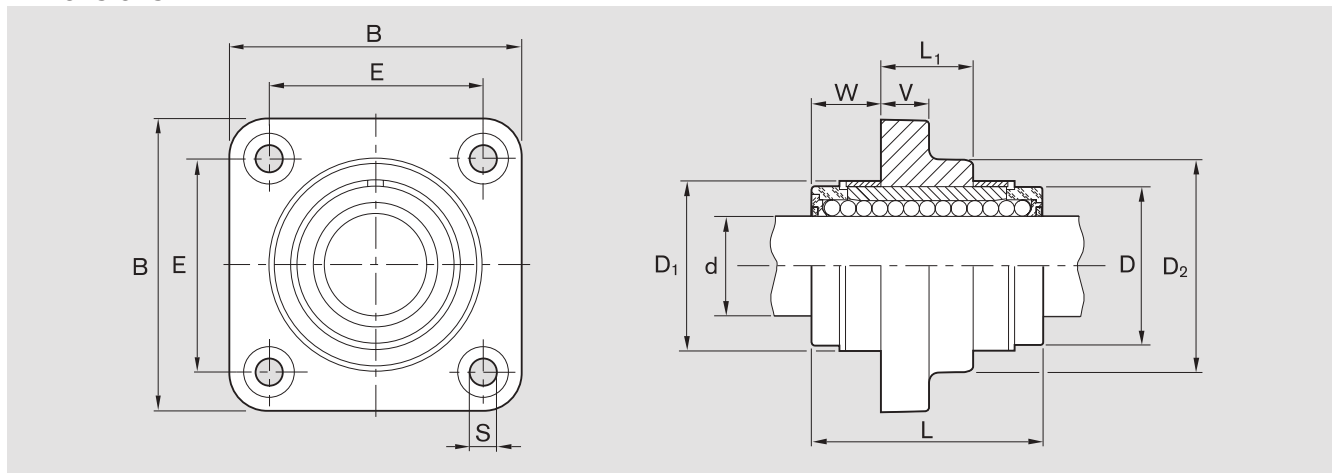

Dimensions (mm)											Radial clearance (µm)		Load ratings (N)	
Ø d	B ¹⁾	L	L ₁	D	D ₁ +0.8	D ₂ ¹⁾	E	S H13	V ¹⁾	M	h6 shaft		dyn. C	stat. C ₀
12	42	32	12	22	24.0	28	30±0.12	5.5	6	10.0	+38 +10		830	420
16	50	36	15	26	28.5	34	35±0.12	5.5	8	10.5	+38 +10		1,020	530
20	60	45	18	32	35.0	42	42±0.15	6.6	10	13.5	+43 +11		2,020	1,050
25	74	58	23	40	43.0	54	54±0.15	6.6	12	17.5	+43 +11		3,950	2,180
30	84	68	26	47	49.5	62	60±0.25	9.0	14	21.0	+43 +11		4,800	2,790
40	108	80	36	62	66.5	80	78±0.25	11	16	22.0	+50 +12		8,240	4,350
50	130	100	72	75	81.0	98	98±0.25	11	18	14.0	+50 +12		12,060	6,470

1) ISO 8062-3 - DCTG 9 tolerance.

The dynamic load ratings are based on a total travel of 100,000 m.



When based on 50,000 m, the C values in the table are multiplied by 1.26.



Super linear bushings  and 

Product overview

The benefits

- High-precision linear bushing for moving heavy loads
- Steel bearing plates with machined ball guide grooves and machined back for high precision
- Super  with more tracks than super 
- Super  with even more tracks for maximum load rating and rigidity
- High travel speed (up to 5 m/s)
- Compensates for shaft deflection and misalignment
- Optional integrated wiper seals
- Optional linear seal for open linear bushing
- Linear sets with aluminum housing



R0732 page 84
Super  (closed)



R0733 page 84
Super  (open)



R0730 page 86
Super  (closed)





R0731 page 86
Super  (open)



Explanation of short product name

Sample linear bushing:

Super linear bushing 
KBSH-O-20-DD

Definition of codes

		KB	SH	O	20	DD	
Type	Linear bushing	=	KB				
Series	Super 	=	H				Seals VD = Fully sealed DD = With two seals D = 1 seal = No seals
	Super 	=	SH				
Form	Closed	=					
	Open	=	O				
Shaft diameter		=	20				

Super linear bushings  and 
Misalignment compensation only

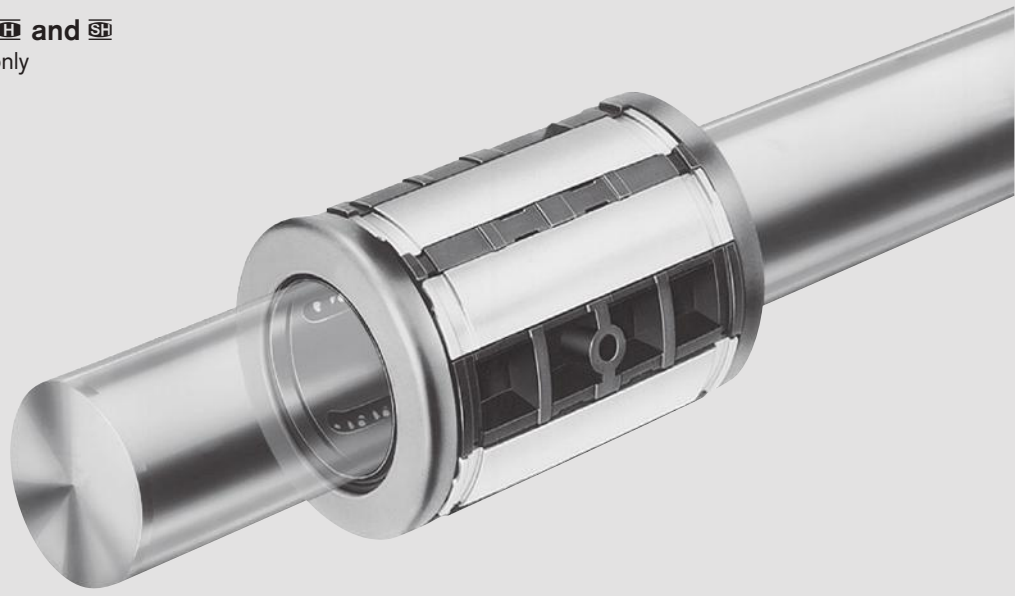

R1701 page 90
Closed



R1702 page 90
Closed, adjustable



R1703 page 92
Open





R1704 page 92
Open, adjustable



R1706 page 94
Side opening, adjustable

Sample linear set:

Linear set with super linear bushing 
LSAH-OE-H-20-DD





Definition of codes		LS	A	H	O	E	H	20	DD	
Type	Linear set	=	LS							
Material (housing) (linear set only)	Aluminum	=	A							Seals
									VD = Fully sealed	
									= With two seals	
									DD No seals	
									20 =	Shaft diameter
									H Super 	Series
									SH Super 	
Form	Heavy-duty	=	H							
	Closed	=								
	Open	=	O							
	Side opening	=	S							
	Adjustable	=	E							

Super linear bushings  and 

Technical data

Please observe general technical principles and follow the lubricating and installation instructions.

Installation dimensions/ interchangeability

Super linear bushings  and  have the same installation dimensions as super linear bushings  and  as well as standard linear bushings, but differ in terms of securing, radial clearance, load ratings and lubrication.

Seal

Double protection through two-sided wiper seals:

- Outer sealing lip prevents dirt from entering
- Inner sealing lip prevents lubricant from escaping

The wiper seals float inside closed linear bushings. This makes them perfect for any operating state.

The open linear bushings are fully sealed with additional side seals along the shaft. All seals can be replaced.

Friction

The friction coefficients μ of the unsealed super linear bushings are 0.001 – 0.004 when lubricated with oil.

The friction coefficient is lowest under high load. It can also be greater than the indicated value under low loads.

The table shows the friction generated by super linear bushings with integrated wiper seals on both ends when not under radial load. They depend on speed and lubrication.

Shaft Ø d (mm)	Closed and open Integrated wiper seals		Open Fully sealed	
	Breakaway force Reference value (N)	Friction Reference value (N)	Breakaway force Reference value (N)	Friction Reference value (N)
20	5	2.5	7.5	4.0
25	7	3.0	10.5	4.5
30	9	4.0	13.5	6.0
40	12	5.0	18.0	7.5
50	15	6.0	22.5	9.0
60	18	7.0	27.0	10.5

Speed

$$v_{\max} = 5 \text{ m/s}$$



Acceleration

$$a_{\max} = 150 \text{ m/s}^2$$

Operating temperature

-20 °C to 80 °C

Initial lubrication

Super linear bushings  and  do not come prelubricated. Grease linear bushings before use, see "Initial lubrication" Section "Lubrication" on page 21. Service life data is based on initial lubrication and relubricated linear bushings.

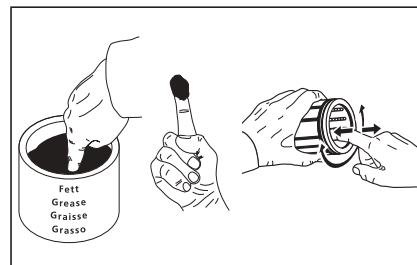

Effect of load direction on load rating

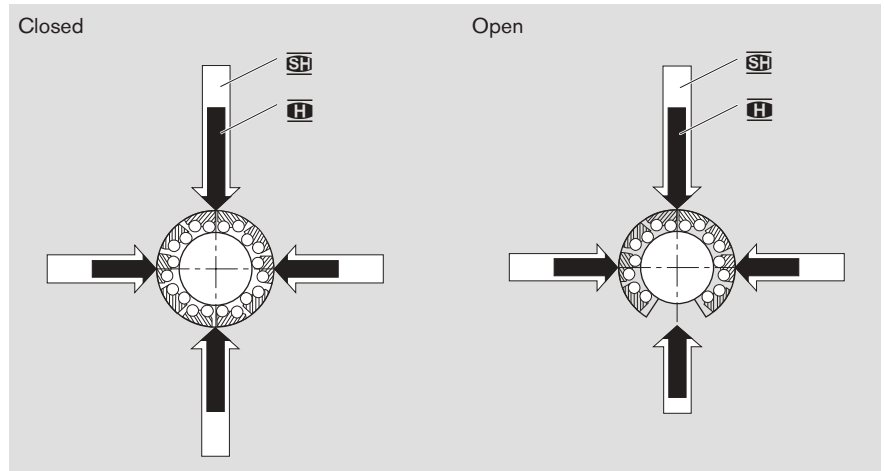

Main load directions

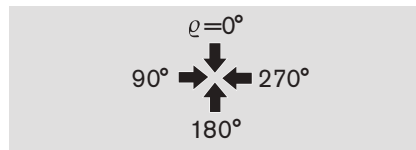

Load direction factors

The load ratings C and C_0 apply for the load direction $\rho = 0^\circ$. For all other load directions, the load ratings must be multiplied by the factors f_ρ (dynamic load rating) or f_{ρ_0} (static load rating C_0).

Shaft $\varnothing d$ (mm)	Load direction factor f_ρ												
	Super linear bushing						Super linear bushing						
	↓	→	←	↑	↓	→	←	↑	↓	→	←	↑	
20-25	1	0.80	0.98	1	1	0.80	0.67	1	0.79	1	1	0.79	0.52
30-60	1	0.70	0.91	1	1	0.70	0.62	1	0.86	1	1	0.86	0.59
	Load direction factor f_{ρ_0}												
20-25	1	0.70	0.87	1	1	0.70	0.67	1	0.68	1	1	0.68	0.50
30-60	1	0.62	0.80	1	1	0.62	0.61	1	0.83	1	1	0.83	0.55



Reduced load rating with short stroke

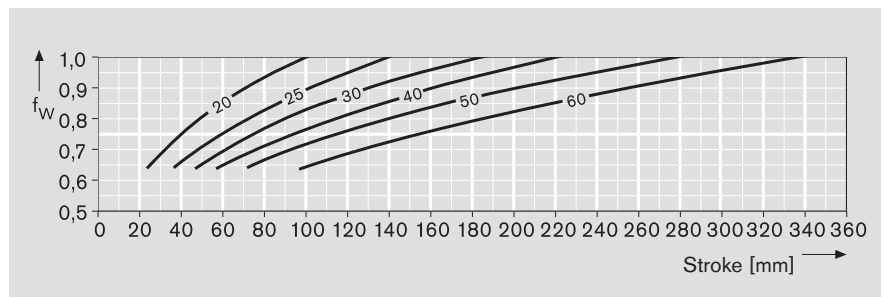

When short stroke is present, the service life of the shaft is less than that of the super linear bushing. The load ratings C in the tables must therefore be multiplied by the factor f_w .

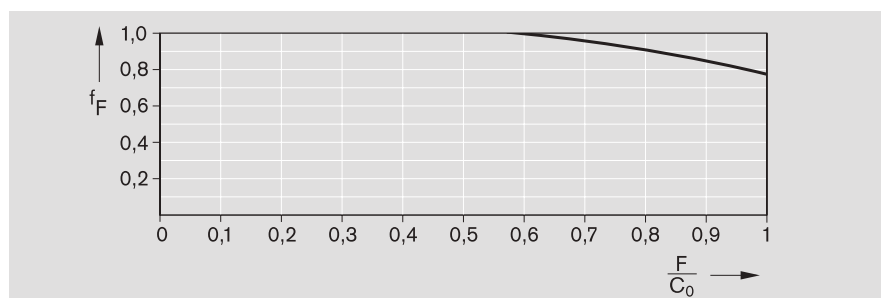

Reduced load rating with heavy load

The load rating is reduced under heavy load F . The dynamic load rating must be multiplied by the load factor f_F .



Super linear bushings  and 

Technical data

Load direction factors for super linear bushing

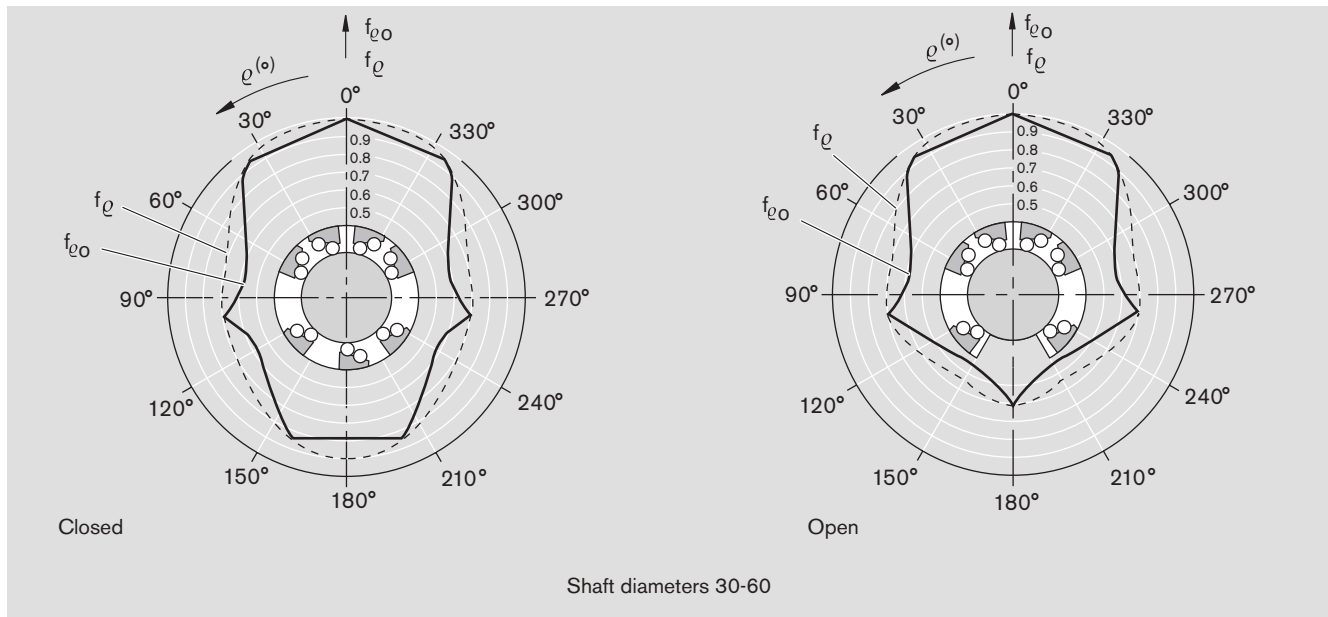
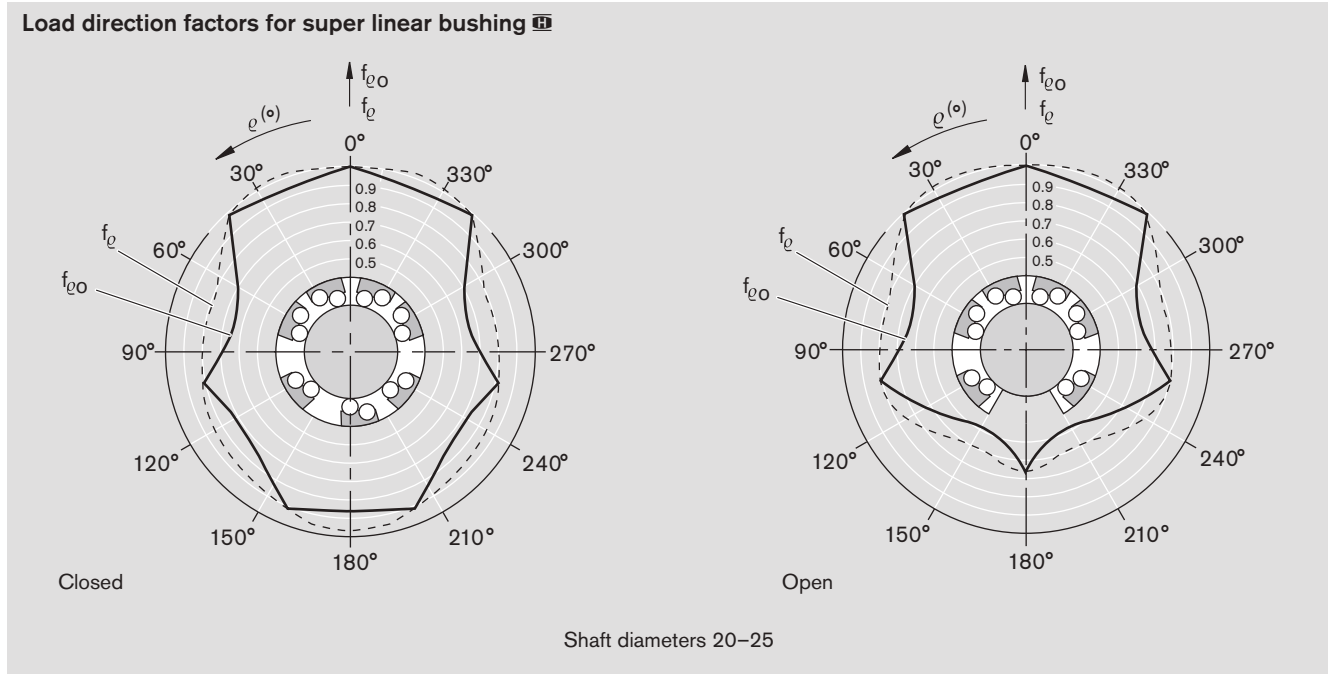

Super linear bushings can be installed in any location.
Choose a location that ensures that the main load direction is always $\rho = 0^\circ$.

Load direction factors for super linear bushing 

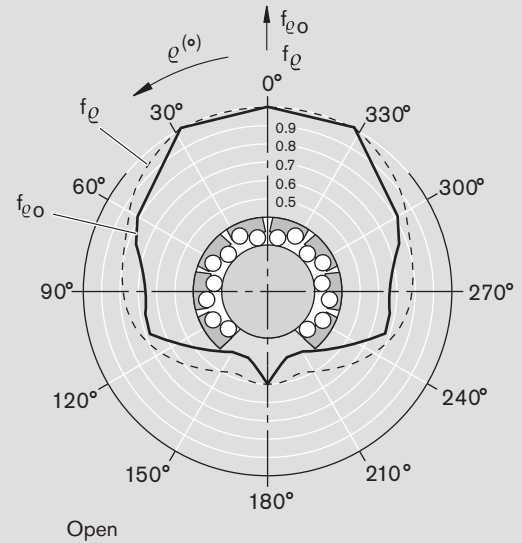
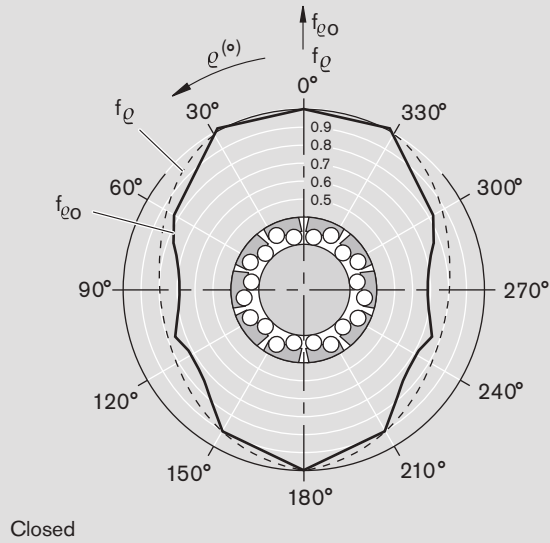

Shaft diameters 20–25

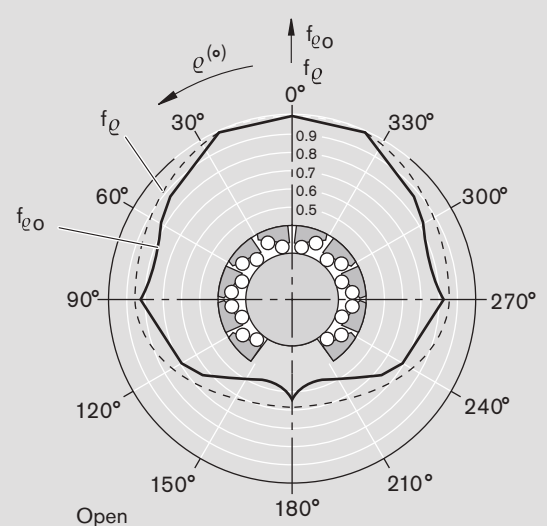
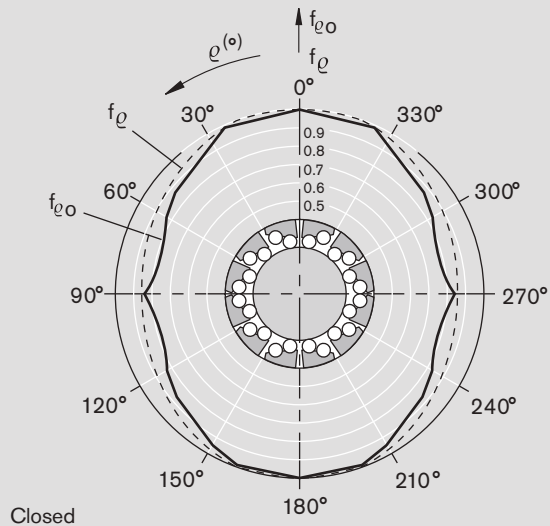



Shaft diameters 30–50

Super linear bushings can be installed in any location. Choose a location that ensures that the main load direction is always $\rho = 0^\circ$.

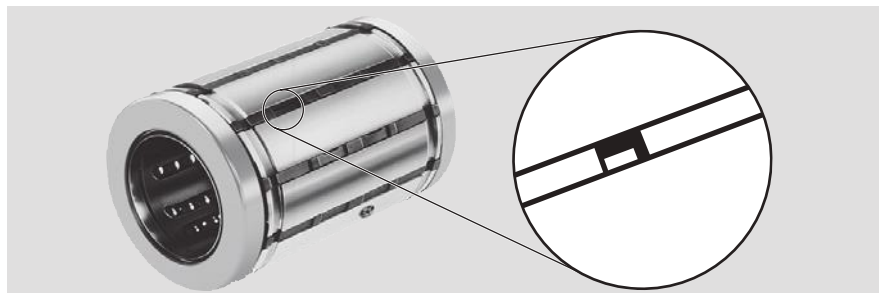
The main load direction $\rho = 0^\circ$ (maximum load rating) is designated in a closed super linear bushing  by a recess in the plastic cage (see enlarged).



Super linear bushings  and 

Customer-built housings

Securing

Super linear bushing



Secured with locating screw via locating hole S_1 .

Note on installation

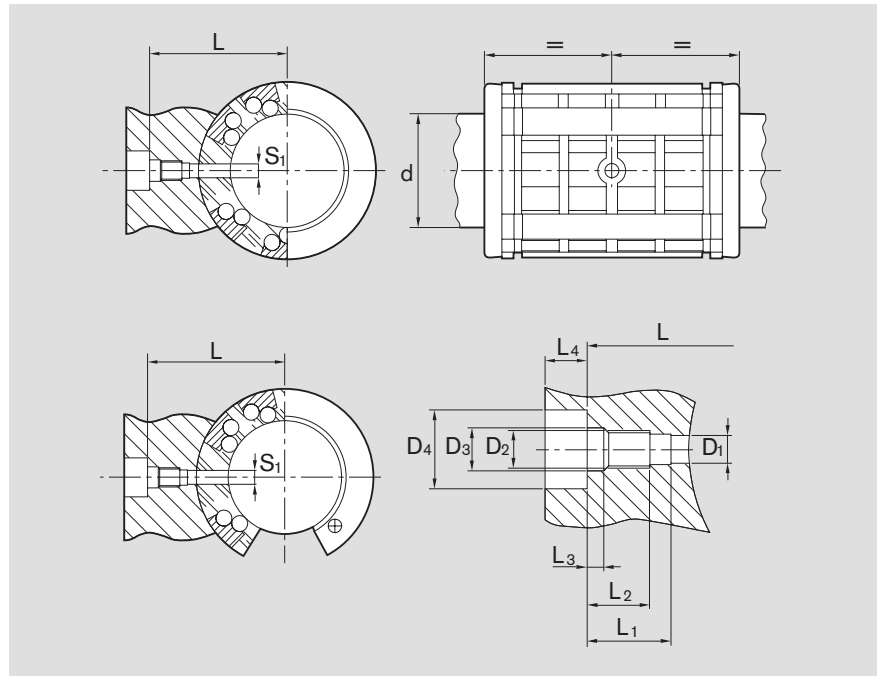
Note the position of the steel bearing plates to the locating hole S_1 .



Shaft $\varnothing d$ (mm)	Dimensions (mm)										Locating screw	
	S_1	L ± 0.1	L_1 $+0.2$	L_2 $+0.2$	L_3 $+0.2$	L_4 min.	D_1 $+0.1$	D_2	D_3 H13	D_4 H13	Material number	Tightening torque (Nm)
20	3.0	27.0	9	7.0	2.0	3.2	3.1	M4	4.5	8	R3427 008 09	1.9
25	3.5	33.5	11	8.5	2.3	4.0	3.6	M5	5.5	10	R3427 003 09	3.8
30	3.5	37.0	11	8.5	2.3	4.0	3.6	M5	5.5	10	R3427 003 09	3.8
40	3.5	44.5	11	8.5	2.3	4.0	3.6	M5	5.5	10	R3427 003 09	3.8
50	4.5	59.5	17	14.0	3.0	4.7	4.6	M6	6.6	11	R3427 004 09	6.7
60	6.0	72.5	22	18.0	4.0	6.0	6.2	M8	9.0	15	R3427 007 09	16.0

Super linear bushings  and 

Customer-built housings

Relubrication and securing

Super linear bushing (closed)

Relubrication and securing via locating hole S_1 .
Dimensions for customer-built housings.

Note on installation:

Note the position of the steel bearing plates to the locating hole S_1 .

The lubricating channels shown are designed for grease. When lubricating with oil, make sure all rolling bearings have been reached.

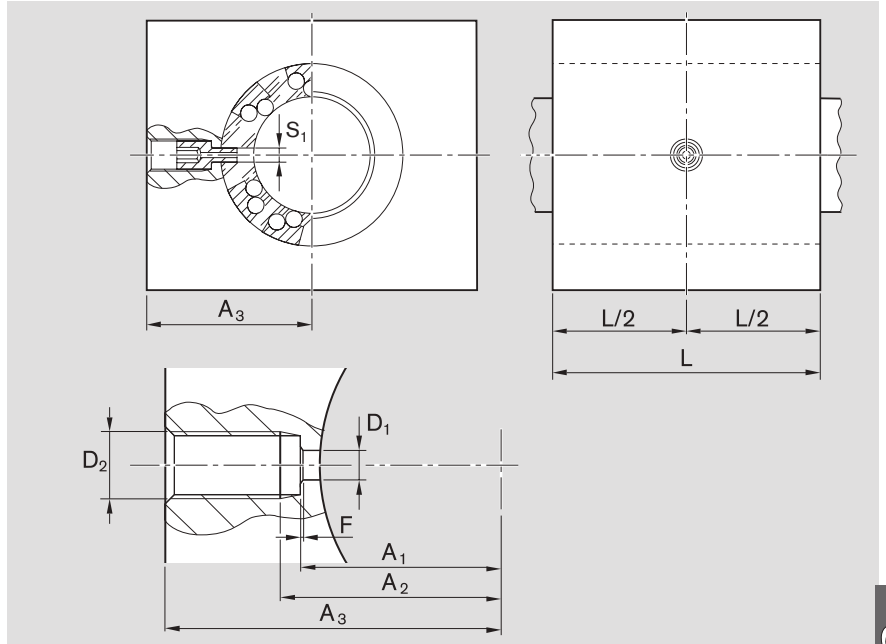

Material number Super linear bushing 	Dimensions (mm)								Hollow bolt	
	S_1	L min.	D_1 +0.1	D_2	A_1 ± 0.1	A_2 max.	A_3 min.	F	Material number	Tightening torque (Nm)
R0732 220 40	3.0	46	3.1	M8x1	18.5	20.5	31.0	0.3x45°	R3432 010 00	5.5
R0732 225 40	3.5	59	3.6	M8x1	22.5	25.0	38.0	0.3x45°	R3432 007 00	5.5
R0732 230 40	3.5	69	3.6	M8x1	26.0	28.5	41.5	0.3x45°	R3432 007 00	5.5
R0732 240 40	3.5	81	3.6	M8x1	33.5	36.0	49.0	0.3x45°	R3432 007 00	5.5
R0732 250 40	4.5	101	4.6	M8x1	42.0	44.5	59.0	0.3x45°	R3432 008 00	5.5
R0732 260 40	6.0	126	6.2	M10x1	51.0	53.5	71.5	0.3x45°	R3432 009 00	9.5

Hollow bolt

for relubricating and securing super linear bushing  (closed) via locating hole S_1 .

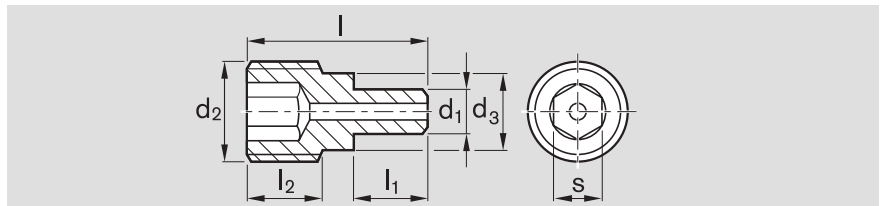

Dimensions (mm)								Hollow bolt	
d_2	d_1	d_3	l	l_1	l_2	s	Material number	Tightening torque (Nm)	
M8x1	3.0	6.5	10.5	5.0	3.5	4	R3432 010 00	5.5	
M8x1	3.5	6.5	14.5	6.0	5.6	4	R3432 007 00	5.5	
M8x1	4.5	6.5	18.0	8.0	7.0	4	R3432 008 00	5.5	
M10x1	6.0	8.5	25.0	11.5	10.2	5	R3432 009 00	9.5	

Super linear bushing 
Secured with locating screw.

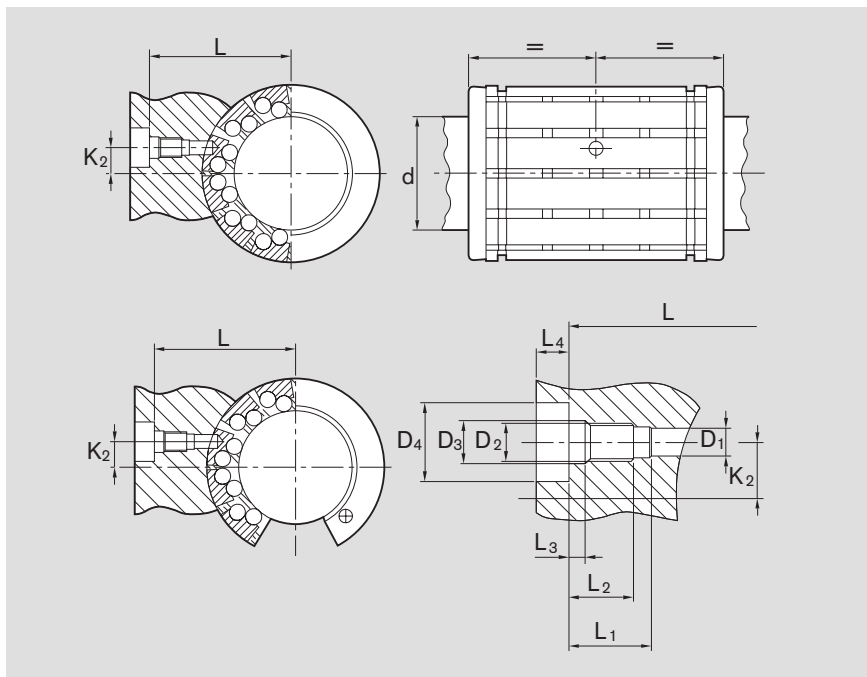

Shaft Ø d (mm)	Dimensions											Locating screw	
	L +0.2	K ₂	L ₁ +0.2	L ₂ min.	L ₃ +0.2	L ₄ min.	D ₁ +0.1	D ₂	D ₃ H13	D ₄ H13	Material number	Tightening torque (Nm)	
20	26.85	1.3	9	7.0	2.0	3.2	2.6	M4	4.5	8	R3427 001 09	1.9	
25	30.75	2.0	9	7.0	2.0	3.2	2.6	M4	4.5	8	R3427 001 09	1.9	
30	38.15	7.0	11	8.5	2.3	4.0	3.6	M5	5.5	10	R3427 003 09	3.8	
40	44.75	9.5	11	8.5	2.3	4.0	3.6	M5	5.5	10	R3427 003 09	3.8	
50	59.75	10.0	17	14.0	3.0	4.7	4.6	M6	6.6	11	R3427 004 09	6.7	

Locating screw
for securing super linear bushing  and .

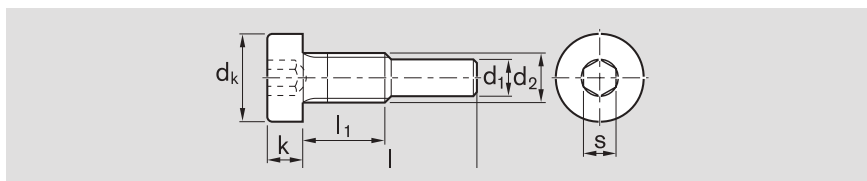

Dimensions (mm)							Locating screw	
d ₂	d _k	d ₁	l	l ₁	k	s	Material number	Tightening torque (Nm)
M4	7.0	2.5	12.0	6.3	2.8	2.5	R3427 001 09	1.9
M4	7.0	3.0	14.1	6.5	2.8	2.5	R3427 008 09	1.9
M5	8.5	3.5	17.0	8.0	3.5	3.0	R3427 003 09	3.8
M6	10.0	4.5	26.0	13.5	4.0	4.0	R3427 004 09	6.7
M8	13.0	6.0	33.0	17.0	5.0	5.0	R3427 007 09	16.0

Other dimensions as per DIN 7984.



Relubrication

Super linear bushing  (closed)

Lubricating channel, radial groove and connection thread for greasing.
Dimensions for customer-built housings.

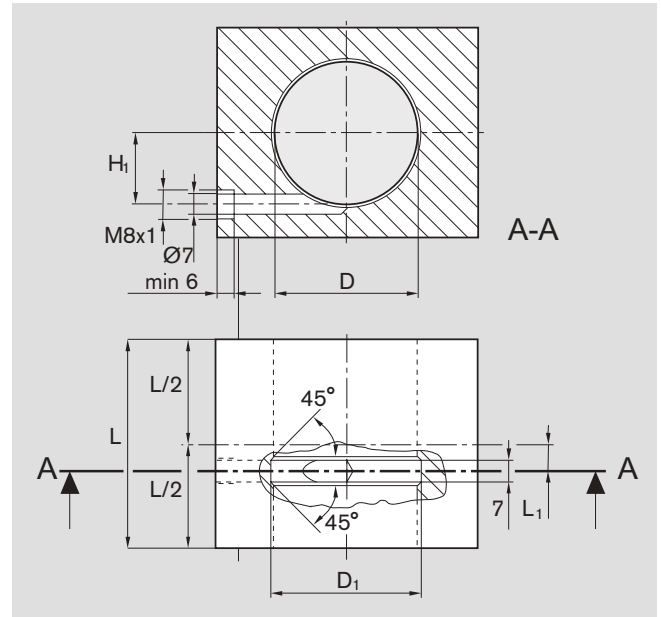

Material number Super linear bushing 	Dimensions (mm)				
	D	L min.	L ₁ +0.5	H ₁	D ₁ ±0.2
R0730 220 40	32	46	7.0	16.0	34
R0730 225 40	40	59	8.5	20.0	42
R0730 230 40	47	69	8.5	23.5	50
R0730 240 40	62	81	10.5	31.0	66
R0730 250 40	75	101	11.5	37.5	79

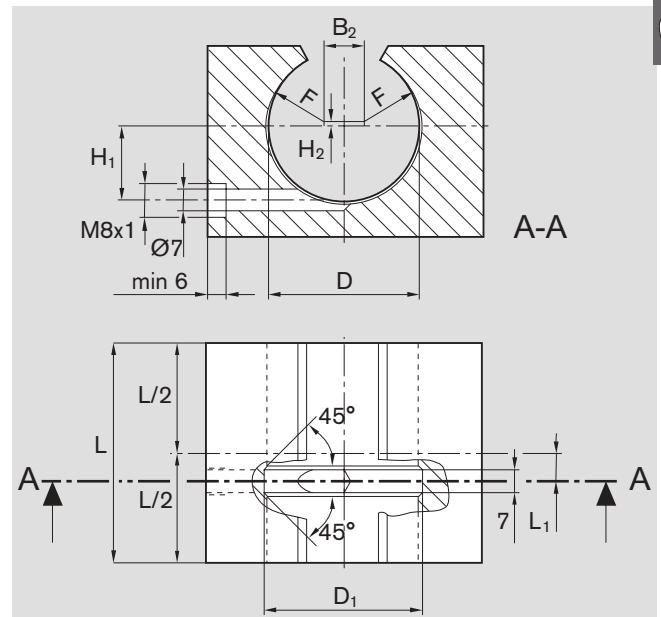

Super linear bushing  and  (open)

Lubricating channel, radial groove and connection thread for greasing.
Dimensions for customer-built housings.



Material number Super linear bushing		Dimensions (mm)							
		D	L min.	L ₁ +0.5	H ₁	D ₁ ±0.2	B ₂	H ₂	F
R0733 220 45	R0731 220 45	32	46	7.0	16.0	34	8.0	-	R13
R0733 225 45	R0731 225 45	40	59	8.5	20.0	42	11.9	0.5	R15
R0733 230 45	R0731 230 45	47	69	8.5	23.5	49	12.8	1.0	R18
R0733 240 45	R0731 240 45	62	81	10.5	31.0	66	19.9	1.1	R23
R0733 250 45	R0731 250 45	75	101	11.5	37.5	79	22.6	2.0	R28
R0733 260 45	-	90	126	13.0	45.0	94	30.8	3.0	R31.5



Super linear bushings 

Super linear bushings, R0732
Closed

Super linear bushings, R0733
Open

Design



- POM ball retainer
- Hardened steel bearing plates with machined ball guide grooves and machined back
- Balls made of rolling bearing steel

- Compensate for misalignments of up to 30 ft
- Two metal retaining rings
- Optional double-lipped wiper seals

- Optional linear seal



See "Technical data – Load direction factors" for exact values for the 4 main load directions.



Shaft Ø d (mm)	Material number		Hollow bolt ¹⁾	Locating screw ²⁾	Weight (kg)
	No Wiper seal KBH- ...	2 wiper seals KBH- ... -DD			
20	R0732 020 00	R0732 220 40	R3432 010 00	R3427 008 09	0.070
25	R0732 025 00	R0732 225 40	R3432 007 00	R3427 003 09	0.150
30	R0732 030 00	R0732 230 40	R3432 007 00	R3427 003 09	0.210
40	R0732 040 00	R0732 240 40	R3432 007 00	R3427 003 09	0.400
50	R0732 050 00	R0732 250 40	R3432 008 00	R3427 004 09	0.700
60	R0732 060 00	R0732 260 40	R3432 009 00	R3427 007 09	1.200
					

1 wiper seal: R0732 1 ... 40 or R0733 1 ... 40



Shaft Ø d (mm)	Material number			Locating screw ²⁾	Weight (kg)
	No Wiper seal KBH-O- ...	2 wiper seals KBH-O- ... DD	Fully sealed KBH-O- ... VD		
20	R0733 020 00	R0733 220 40	R0733 220 45	R3427 008 09	0.060
25	R0733 025 00	R0733 225 40	R0733 225 45	R3427 003 09	0.130
30	R0733 030 00	R0733 230 40	R0733 230 45	R3427 003 09	0.180
40	R0733 040 00	R0733 240 40	R0733 240 45	R3427 003 09	0.350
50	R0733 050 00	R0733 250 40	R0733 250 45	R3427 004 09	0.600
60	R0733 060 00	R0733 260 40	R0733 260 45	R3427 007 09	1.000
					

1) See page 81 for dimensions

2) See page 82 for dimensions

Explanation of sample short product name

KB	H	O	20	DD
Linear bushing	Super 	Open	Ø 20	Two seals

See page 74 for more information on short product names.

Dimensions

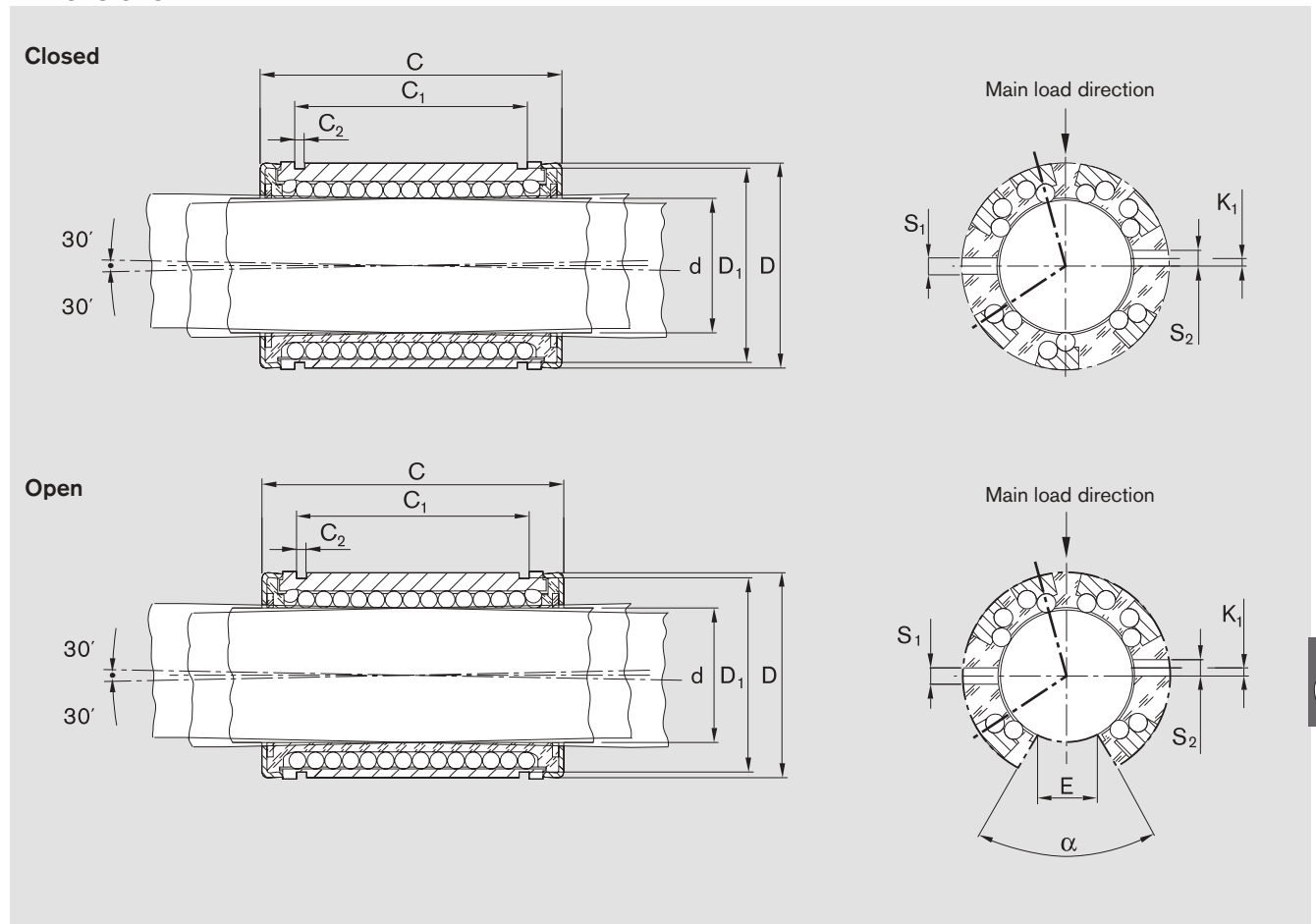

Dimensions (mm)										Rows of balls		Angle α (°)	Radial clearance (μm)			Load ratings ²⁾ (N)	
$\varnothing d$	D	C h13	C ₁ H13	C ₂	D ₁	S ₁ ¹⁾ +0.1	S ₂ ¹⁾ +0.1	K ₁	E ²⁾				Shaft/bore			dyn. C	stat. C ₀
												h6/H7	h6/K7	h6/M7			
20	32	45	31.2	1.6	30.5	3.0	-	-	9.5	7	6	+43 +11	+25 -7	+18 -14	2,520	1,880	
25	40	58	43.7	1.85	38.5	3.5	3	-1.5	12.0	7	6	+43 +11	+25 -7	+18 -14	4,430	3,360	
30	47	68	51.7	1.85	44.5	3.5	3	2.0	12.8	7	6	+43 +11	+25 -7	+18 -14	6,300	5,230	
40	62	80	60.3	2.15	59.0	3.5	3	1.5	16.8	7	6	+50 +12	+29 -7	+20 -18	9,680	7,600	
50	75	100	77.3	2.65	72.0	4.5	5	2.5	22.1	7	6	+50 +12	+29 -7	+20 -18	16,000	12,200	
60	90	125	101.3	3.15	86.5	6.0	-	-	27.0	7	6	+56 +14	+31 -11	+21 -21	23,500	18,700	

- 1) Holes at center of dimension C
- 2) Minimum size in relation to $\varnothing d$
- 3) The load ratings apply for the main load direction

The dynamic load ratings are based on a total travel of 100,000 m.
When based on 50,000 m, the C values in the table are multiplied by 1.26.

Refer to the diagrams on page 78 for load in the direction of opening.

Super linear bushings 

Super linear bushings, R0730

Closed

Super linear bushings, R0731

Open

Design

- POM ball retainer
- Hardened steel bearing plates with machined ball guide grooves and machined back

- Balls made of rolling bearing steel
- Compensate for misalignments of up to 30 ft
- Two metal retaining rings

- Optional double-lipped wiper seals
- Optional linear seals

See "Technical data – Load direction factors" for exact values for the 4 main load directions.

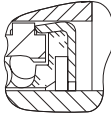
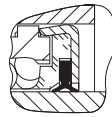

Shaft Ø d (mm)	Material number			Locating screw	Weight (kg)
	No wiper seal KBSH- ...	With two wiper seals KBSH- ... -DD			
20	R0730 020 00	R0730 220 40		R3427 001 09	0.009
25	R0730 025 00	R0730 225 40		R3427 001 09	0.190
30	R0730 030 00	R0730 230 40		R3427 003 09	0.300
40	R0730 040 00	R0730 240 40		R3427 003 09	0.600
50	R0730 050 00	R0730 250 40		R3427 004 09	1.050
					

1 wiper seal: R0730 1 ... 40 or R0731 1 ... 40.

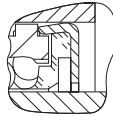
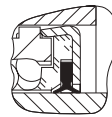
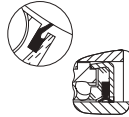

Shaft Ø d (mm)	Material number			Locating screw	Weight (kg)
	No wiper seal KBSH-O- ...	2 wiper seals KBSH-O- ... -DD	Fully sealed KBSH-O- ... -VD		
20	R0731 020 00	R0731 220 40	R0731 220 45	R3427 001 09	0.075
25	R0731 025 00	R0731 225 40	R0731 225 45	R3427 001 09	0.160
30	R0731 030 00	R0731 230 40	R0731 230 45	R3427 003 09	0.250
40	R0731 040 00	R0731 240 40	R0731 240 45	R3427 003 09	0.500
50	R0731 050 00	R0731 250 40	R0731 250 45	R3427 004 09	0.900
					

1) See page 81 for dimensions

2) See page 82 for dimensions

Explanation of sample short product name

KB	SH	O	20	DD
Linear bushing	Super 	Open	Ø 20	Two seals

See page 74 for more information on short product names.

Dimensions

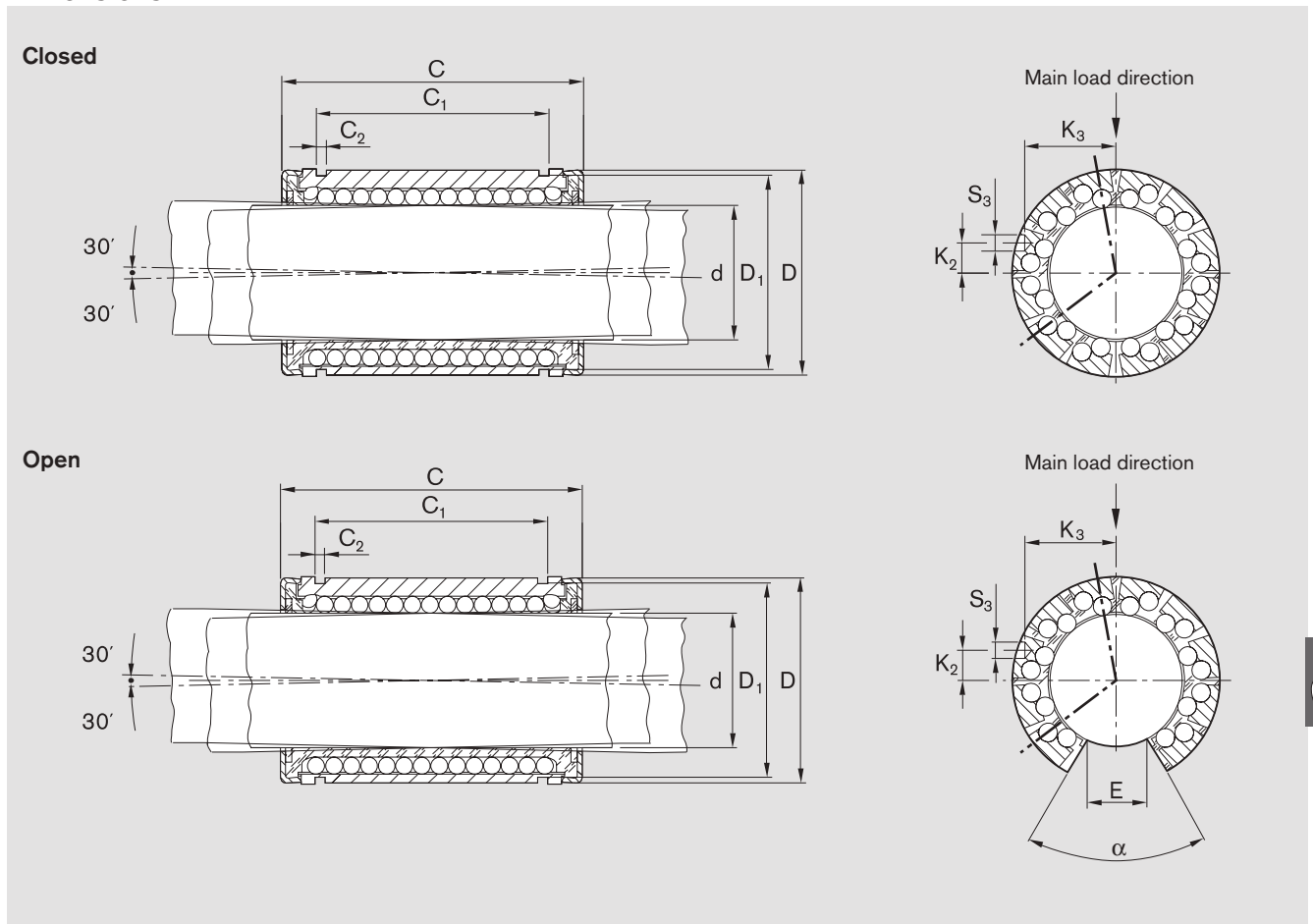



Dimensions (mm)										Rows of balls		Angle α (°)	Radial clearance (μm)			Load ratings ²⁾ (N)	
$\varnothing d$	D	C	C ₁	C ₂	D ₁	S ₃ ¹⁾	K ₂	K ₃	E ²⁾				Shaft/bore			dyn. C	stat. C ₀
		h13	H13			+0.1						h6/H7	h6/K7	h6/M7			
20	32	45	31.2	1.60	30.5	3.0	1.3	14.7	9.5	10	8	+43 +11	+25 -7	+18 -14	3,530	2,530	
25	40	58	43.7	1.85	38.5	3.5	2.0	18.5	12.0	10	8	+43 +11	+25 -7	+18 -14	6,190	4,530	
30	47	68	51.7	1.85	44.5	3.5	7.0	21.0	12.8	12	10	+43 +11	+25 -7	+18 -14	6,300	7,180	
40	62	80	60.3	2.15	59.0	3.5	9.5	27.5	16.8	12	10	+50 +12	+29 -7	+20 -18	13,500	10,400	
50	75	100	77.3	2.65	72.0	4.5	10.0	33.5	22.1	12	10	+50 +12	+29 -7	+20 -18	22,300	16,800	

- 1) Hole at center of dimension C
- 2) Minimum size in relation to $\varnothing d$
- 3) The load ratings apply for the main load direction

The dynamic load ratings are based on a total travel of 100,000 m.
When based on 50,000 m, the C values in the table are multiplied by 1.26.

Refer to the diagrams on page 79 for load in the direction of opening.

Linear sets with super linear bushings  or 

Technical data

Tolerances and guide parallelism in operation

R1703 and R1704 linear sets and steel shaft with ready-mounted R1014 shaft support rail

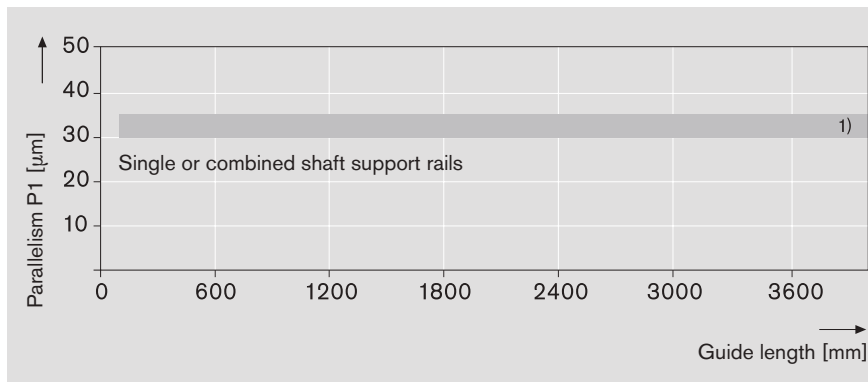

R1703 and R1704 linear sets and steel shaft with ready-mounted R1016 shaft support rail

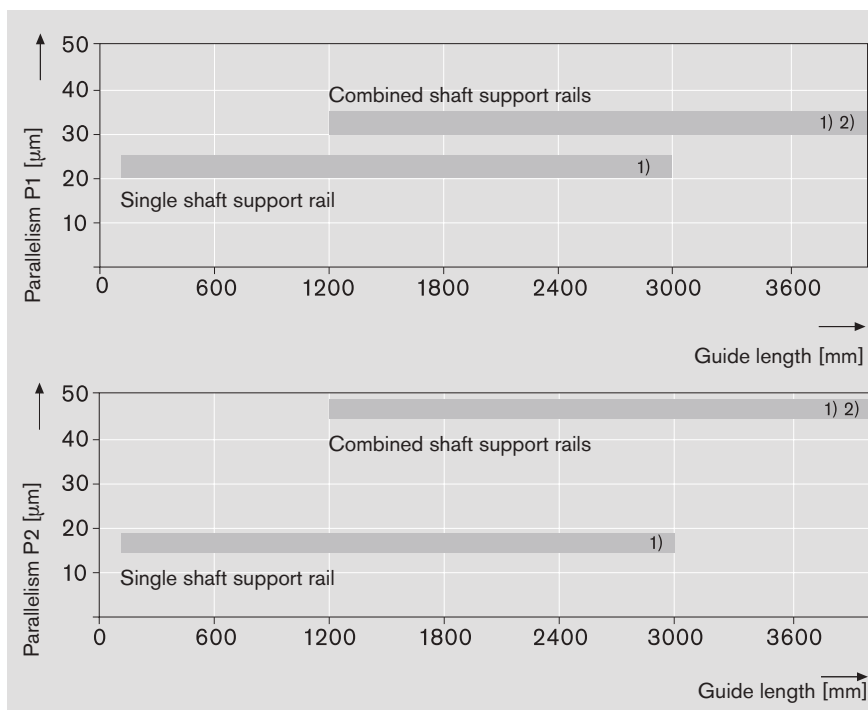

R1706 linear sets and steel shaft with ready-mounted R1015 shaft support rail

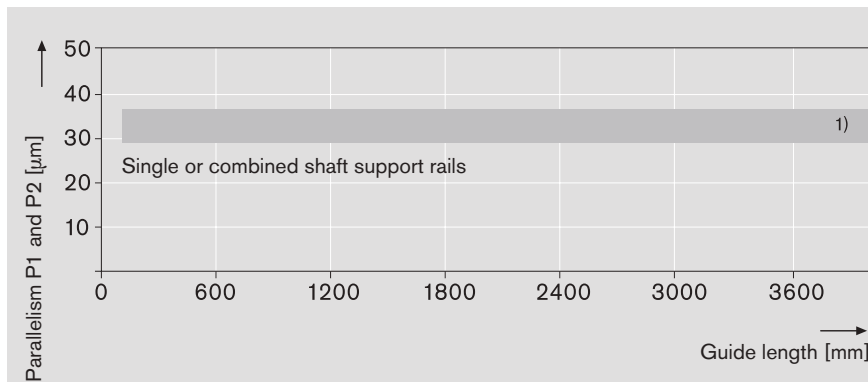

1) See "Tolerances" table for exact values.

2) Shaft support rail consists of multiple parts of same type.

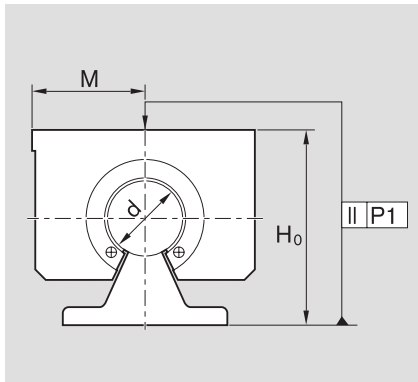

Tolerances ⁵⁾ (µm)	Shaft tolerance zone	Shaft Ø d (mm)							
		20	25	30	40	50	60		
Dimension H ₀ ^{3) 6)}	h6	+18	-39	+18	-39	+18	-42	+18	-45
	h7	+18	-47	+18	-47	+18	-51	+18	-56
Parallelism P1 ^{4) 6)}	h6	30	30	30	32	33			
	h7	32	32	32	35	35			

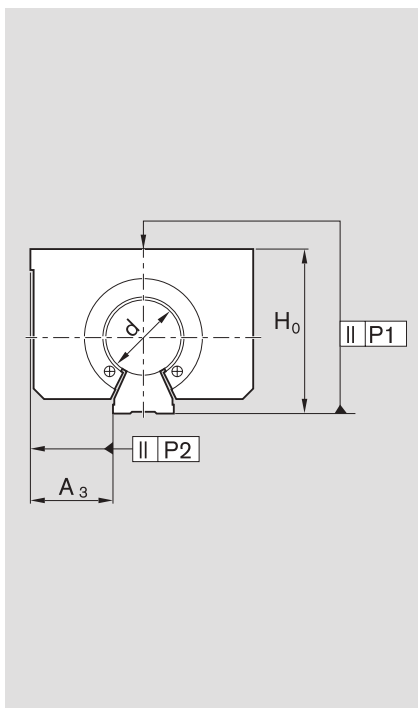

Tolerances ⁵⁾ (µm)	Shaft tolerance zone	Shaft Ø d (mm)				
		20	25	30	40	50
Dimension H ₀ ²⁾	h6	+28	+28	+28	+28	+28
	h7	+28	-77	+28	-77	+28
Multiple shaft support rails	h6	-69	-69	-69	-72	-72
	h7	+28	-77	+28	-77	+28
Dimension H ₀ ²⁾	h6	57	57	57	60	60
	h7	65	65	65	67	69
Single shaft support rail	h6	30	30	30	32	32
	h7	32	32	32	35	35
Combined shaft support rails	h6	20	20	20	22	22
	h7	22	22	22	25	25
Parallelism P1 ⁴⁾	h6	45	45	45	46	46
	h7	46	46	46	48	48
Parallelism P2 ⁴⁾	h6	15	15	15	16	16
	h7	16	16	16	18	18
Combined shaft support rails	h6	+30	+30	+30	+30	+30
	h7	+30	-37	+30	-37	+30
Single shaft support rail	h6	+30	+30	+30	+30	+30
	h7	+30	-41	+30	-41	+30
Dimension A ₃ ²⁾	h6	+30	+30	+30	+30	+30
	h7	+30	-37	+30	-37	+30
Parallelism P1 ⁴⁾	h6	29	29	29	30	30
	h7	30	30	30	32	32
Parallelism P2 ⁴⁾	h6	29	29	29	34	34
	h7	31	31	31	37	37

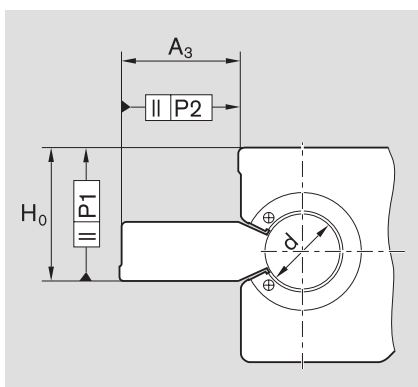

Tolerances ⁵⁾ (µm)	Shaft tolerance zone	Shaft Ø d (mm)					
		20	25	30	40	50	
Dimension H ₀ ^{2), 6)}	h6	+20	-35	+20	-35	+20	-36
	h7	+20	-39	+20	-39	+20	-41
Dimension A ₃ ²⁾	h6	+20	-33	+20	-33	+21	-37
	h7	+20	-41	+20	-41	+21	-46
Parallelism P1 ^{4), 6)}	h6	29	29	29	30	30	
	h7	30	30	30	32	32	
Parallelism P2 ^{4), 6)}	h6	29	29	29	34	34	
	h7	31	31	31	37	37	



- 3) Measured from center of housing.
- 4) With clamped and fastened guide.
- 5) The tolerances apply for the set with shaft and shaft support rail.
- 6) Single or combined shaft support rails

Linear sets with super linear bushings  or 

Linear sets, R1701 Closed





Linear sets, R1702 Adjustable

Design





- Precision housing (aluminum)
- Super linear bushing  or 
- Compensate for misalignments of up to 30 ft
- Integrated wiper seals
- Secured with bolt
- Relubricatable

See "Technical data – Load direction factors" for exact values for the 4 main load directions.



Shaft Ø d (mm)	Material number Super linear bushing		Weight (kg) Super linear bushing	
				
20	LSAH-H- ... -DD	LSAH-H- ... -DD	0.29	0.31
25	R1701 220 20	R1701 420 20	0.58	0.63
30	R1701 225 20	R1701 425 20	0.88	0.97
40	R1701 230 20	R1701 430 20	1.63	1.86
50	R1701 240 20	R1701 440 20	2.70	3.10
60	R1701 250 20	R1701 450 20	5.20	–
	R1701 260 20	–		–



Shaft Ø d (mm)	Material number Super linear bushing		Weight (kg) Super linear bushing	
				
20	LSAHE-H- ... -DD	LSAHE-SH- ... -DD	0.29	0.31
25	R1702 220 20	R1702 420 20	0.58	0.63
30	R1702 225 20	R1702 425 20	0.88	0.97
40	R1702 230 20	R1702 430 20	1.63	1.86
50	R1702 240 20	R1702 440 20	2.70	3.10
60	R1702 250 20	R1702 450 20	5.20	–
	R1702 260 20	–		–

Explanation of sample short product name

LS	A	HE	H	20	DD
Closed linear set	Aluminum	Heavy-duty, adjustable	Super linear bushing 	Ø 20	Two seals

See page 75 for more information on short product names.

Dimensions

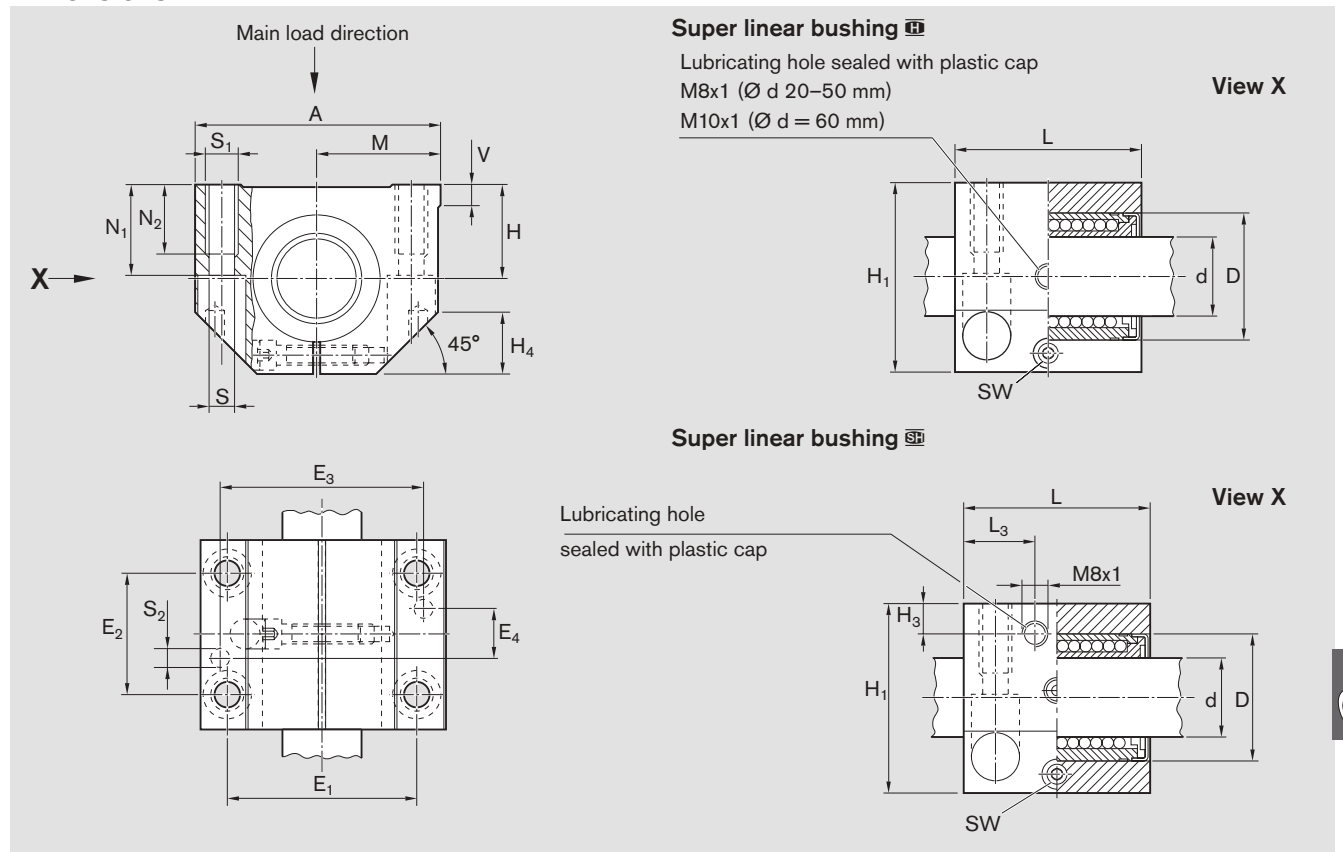



Dimensions (mm)																				
Ø d	D	H ¹⁾ +0.008 -0.016	H ₁	M ¹⁾ ±0.01	A	L	E ₁	E ₂	E ₃	E ₄	S	S ₁	S ₂	N ₁	N ₂	H ₃	L ₃	V	SW	H ₄
20	32	25	50	30.0	60	46	45±0.15	32±0.15	50	15	6.6	M8	5	24	18	10.0	16	5.0	4	16
25	40	30	60	39.0	78	59	60±0.15	40±0.15	64	17	8.4	M10	6	29	22	10.0	21	6.5	5	20
30	47	35	70	43.5	87	69	68±0.15	45±0.15	72	20	8.4	M10	6	34	22	11.5	26	8.0	5	22
40	62	45	90	54.0	108	81	86±0.15	58±0.15	90	25	10.5	M12	8	44	26	14.0	30	10.0	6	28
50	75	50	105	66.0	132	101	108±0.20	50±0.20	108	85	13.5	M16	10	49	34	12.5	39	12.0	8	37
60	90	60	125	82.0	164	126	132±0.20	65±0.20	132	108	17.5	M20	12	59	42	-	-	13.0	10	45

Shaft Ø d (mm)	Radial clearance ²⁾ (µm)		Load ratings ²⁾ (N)			
	R1701 Shaft h6	R1702	Super linear bushing		Super linear bushing	
			dyn. C	stat. C ₀	dyn. C	stat. C ₀
20	+43 +11	Comes clamped to h5 shaft (lower limit) and set to zero clearance	2,520	1,880	3,530	2,530
25	+43 +11		4,430	3,360	6,190	4,530
30	+43 +11		6,300	5,230	8,800	7,180
40	+50 +12		9,680	7,600	13,500	10,400
50	+50 +12		16,000	12,200	22,300	16,800
60	+56 +14		23,500	18,700	-	-

- 1) Clamped (fastened) in relation to Ø d.
- 2) Clamped (fastened).
- 3) The load ratings apply for the main load direction.

The dynamic load ratings are based on total travel of 100,000 m. When based on 50,000 m, the C values in the table are multiplied by 1.26.





Linear sets with super linear bushings  or 

Linear sets, R1703 Open





Linear sets, R1704 Open, adjustable

Design



- Precision housing (aluminum)
- Super linear bushing  or 
- Compensate for misalignments of up to 30 ft
- Fully sealed
- Secured with bolt
- Relubricatable

See "Technical data – Load direction factors" for exact values for the 4 main load directions.



Shaft Ø d (mm)	Material number Super linear bushing ¹⁾		Weight (kg) Super linear bushing	
				
	LSAHO-H- ... -VD	LSAHO-SH- ... -VD		
20	R1703 220 70	R1703 420 70	0.24	0.26
25	R1703 225 70	R1703 425 70	0.48	0.51
30	R1703 230 70	R1703 430 70	0.72	0.79
40	R1703 240 70	R1703 440 70	1.38	1.56
50	R1703 250 70	R1704 450 70	2.30	2.60
60	R1703 260 70	–	4.40	–



Shaft Ø d (mm)	Material number Super linear bushing ¹⁾		Weight (kg) Super linear bushing	
				
	LSAHOE-H- ... -VD	LSAHOE-SH- ... -VD		
20	R1704 220 70	R1704 420 70	0.24	0.26
25	R1704 225 70	R1704 425 70	0.48	0.51
30	R1704 230 70	R1704 430 70	0.72	0.79
40	R1704 240 70	R1704 440 70	1.38	1.56
50	R1704 250 70	R1704 450 70	2.30	2.60
60	R1704 260 70	–	4.40	–

1) Fully sealed, relubricatable

Explanation of sample short product name

LS	A	HOE	H	20	VD
Linear set	Aluminum	Heavy-duty, open, adjustable	Super linear bushing 	Ø 20	Fully sealed

See page 75 for more information on short product names.

Dimensions

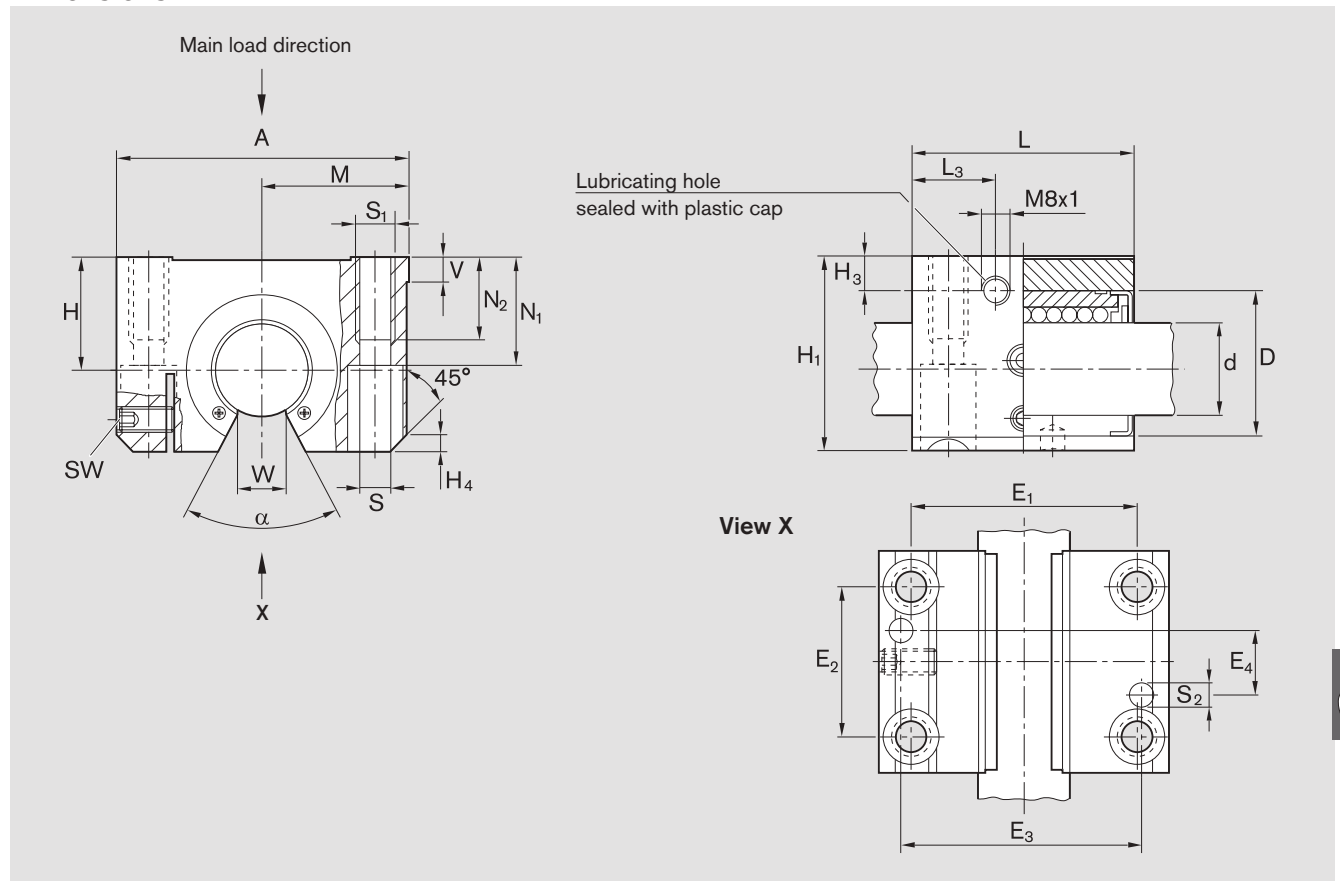

Dimensions (mm)																						
∅ d	D	H ¹⁾ +0.008 -0.016	H ₁	M ¹⁾ ±0.01	A	L	E ₁	E ₂	E ₃	E ₄	S	S ₁	S ₂	N ₁	N ₂	H ₃	L ₃	V	SW	M	H ₄	
20	32	25	42	30.0	60	46	45±0.15	32±0.15	50	15	6.6	M8	5	24	18	10.0	16	5.0	2.5	9.5	3.5	
25	40	30	51	39.0	78	59	60±0.15	40±0.15	64	17	8.4	M10	6	29	22	10.0	21	6.5	3.0	12.0	4.0	
30	47	35	60	43.5	87	69	68±0.15	45±0.15	72	20	8.4	M10	6	34	22	11.5	26	8.0	3.0	12.8	6.0	
40	62	45	77	54.0	108	81	86±0.15	58±0.15	90	25	10.5	M12	8	44	26	14.0	30	10.0	4.0	16.8	6.0	
50	75	50	88	66.0	132	101	108±0.20	50±0.20	108	35	13.5	M16	10	49	34	12.5	39	12.0	5.0	22.1	6.0	
60	90	60	105	82.0	164	126	132±0.20	65±0.20	132	45	17.5	M20	12	59	42	15.0	50	13.0	6.0	27.0	5.0	



Shaft ∅ d (mm)	Angle α (°)	Radial clearance ²⁾ (μm)		Load ratings ²⁾ (N)			
		R1073 Shaft h6	R1074	Super linear bushing		SE	
				dyn. C	stat. C ₀	dyn. C	stat. C ₀
20	54	+31 -2	Comes clamped to h5 shaft (lower limit) and set to zero clearance	2,520	1,880	3,530	2,530
25	55	+31 -2		4,430	3,360	6,190	4,530
30	60	+31 -2		6,300	5,230	8,800	7,180
40	60	+35 -3		9,680	7,600	13,500	10,400
50	52	+35 -3		16,000	12,200	22,300	16,800
60	55	+39 -4		23,500	18,700	-	-

- 1) Clamped (fastened) in relation to ∅ d.
- 2) Clamped (fastened).
- 3) The load ratings apply for the main load direction.

The dynamic load ratings are based on total travel of 100,000 m. When based on 50,000 m, the C values in the table are multiplied by 1.26.



⚠ Refer to the diagrams on page 78 and page 79 for load in the direction of opening.



Linear sets with super linear bushings  or 





Linear sets, R1706 Side opening, adjustable

Design

- Precision housing (aluminum)
- Super linear bushing  or 
- Compensate for misalignments of up to 30 ft
- Fully sealed
- Secured with bolt
- Relubricatable

See “Technical data – Load direction factors” for exact values for the 4 main load directions.



Shaft Ø d (mm)	Material number Super linear bushing ¹⁾		Weight (kg) Super linear bushing	
				
	LSAHSE-H- ... -VD	LSAHSE-SH- ... -VD		
20	R1706 220 70	R1706 420 70	0.35	0.37
25	R1706 225 70	R1706 425 70	0.70	0.73
30	R1706 230 70	R1706 430 70	1.03	1.10
40	R1706 240 70	R1706 440 70	1.80	1.95
50	R1706 250 70	R1706 450 70	3.00	3.25

1) Fully sealed, relubricatable

Explanation of sample short product name

LS	A	HSE	H	20	VD
Linear set	Aluminum	Heavy-duty, side opening, adjustable	Super linear bushing 	Ø 20	Fully sealed

See page 75 for more information on short product names.

Dimensions

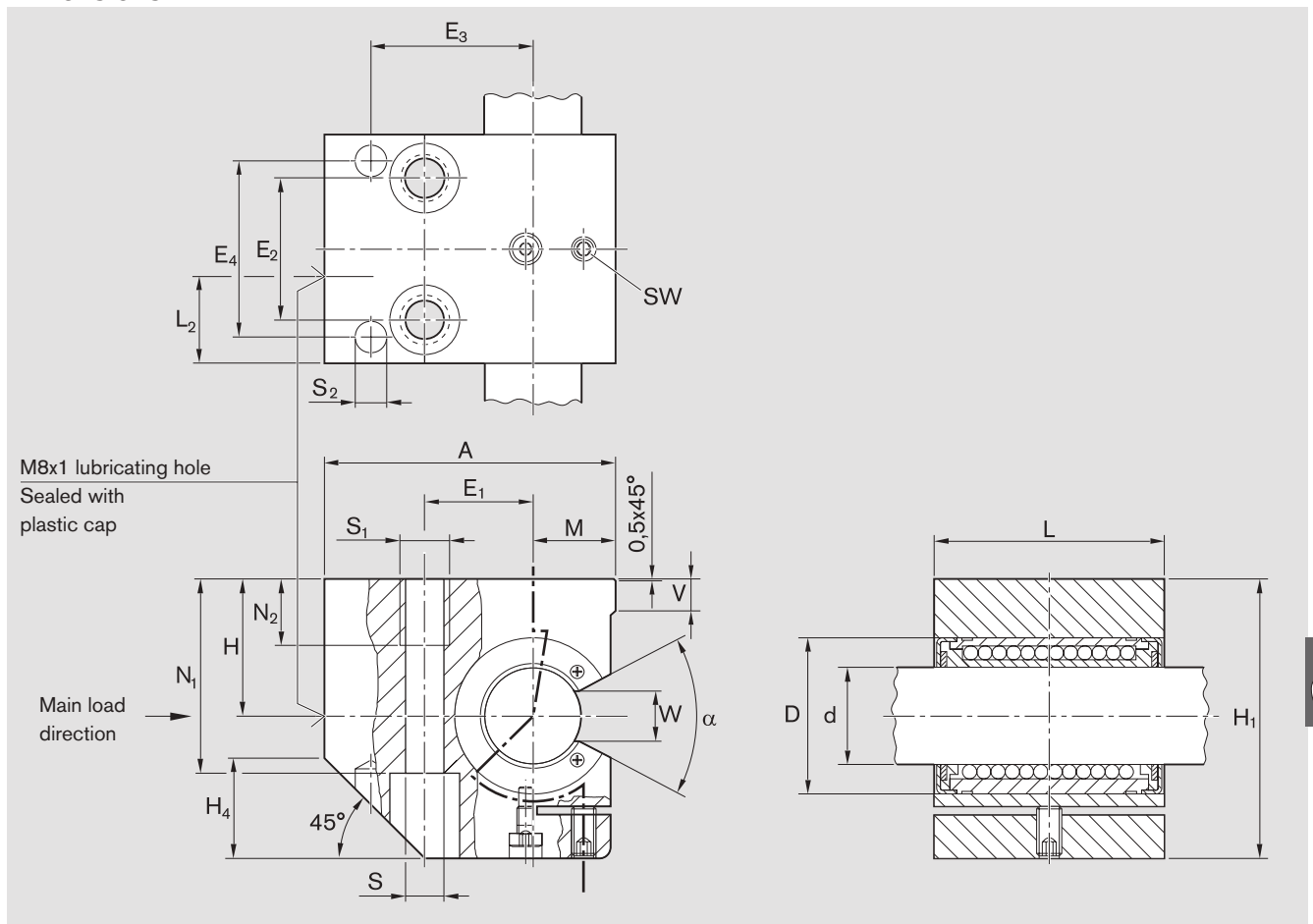

Dimensions (mm)

Ø d	D	H ¹⁾ +0.008 -0.016	H ₁	M ¹⁾ ±0.01	A	L	E ₁	E ₂	E ₃	E ₄	S	S ₁	S ₂	N ₁	N ₂	L ₂	V	SW	M	H ₄
20	32	30	60	17	60	47	22±0.15	30±0.15	35	35	8.4	M10	6	42	15	17.5	5.0	2.5	9.5	22
25	40	35	72	21	75	59	28±0.15	36±0.15	42	45	10.5	M12	8	50	18	22.0	6.5	3.0	12.0	26
30	47	40	82	25	86	69	34±0.15	42±0.15	52	52	13.5	M16	10	55	24	27.0	8.0	30.0	12.8	30
40	62	45	100	32	110	81	43±0.15	48±0.15	65	60	15.5	M20	12	67	30	31.0	10.0	4.0	16.8	38
50	75	50	115	38	127	101	50±0.15	62±0.15	75	75	17.5	M20	12	78	30	39.0	12.0	5.0	22.1	45

Shaft Ø d (mm)	Angle α (°)	Radial clearance (µm)	Load ratings ²⁾ (N)			
			Super linear bushing		SP	
			dyn. C	stat. C ₀	dyn. C	stat. C ₀
20	54	Comes clamped to h5 shaft (lower limit) and set to zero clearance	2,520	1,880	3,530	2,530
25	55		4,430	3,360	6,190	4,530
30	60		6,300	5,230	8,800	7,180
40	60		9,680	7,600	13,500	10,400
50	52		16,000	12,200	22,300	16,800

The dynamic load ratings are based on a total travel of 100,000 m. When based on 50,000 m, the C values in the table are multiplied by 1.26.

⚠ Refer to the diagrams on page 78 and page 79 for load in the direction of opening.

- 1) Clamped (fastened) in relation to Ø d.
- 2) The load ratings apply for the main load direction.

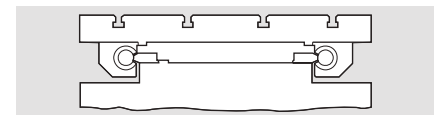

Standard linear bushings

Product overview

The benefits

- Rugged all-metal design with steel ball retainer for harsh environments with heavy contamination
- For use in woodworking, foundries, cement plants
- Also available in stainless steel for medical, chemistry and food industries
- Multiple pockets act as lubricant reservoirs for extended lubrication intervals or lubrication for life.
- Pockets also collect any dirt that may have worked its way in to prevent the linear bushing from jamming.
- Seal-free and with steel ball retainers for temperatures well above 80 °C or under vacuum
- Various flanged versions
- Optional integrated wiper seals
- Linear sets with cast iron/steel/aluminum housing



R0602 page 104

Closed



R0612 page 108

Adjustable



R0632 page 110

Open



R0650 page 112

Tandem



R0740 page 114

Flanged



R0741 page 116

Flanged tandem



R0742 page 118

Central flanged

Explanation of short product name

Sample linear bushing:

Standard linear bushing
KBM-FT-20-DD-NR

Definition of codes		KB	M	F	T	20	DD	NR	
Type	Linear bushing	=	KB						Version
Series	Standard (metal)	=	M						
Form	Closed	=							Seals
	Open	=		O					
	Adjustable	=		E					
	Flanged	=		F					
	Tandem	=		T					
	Central flanged	=		M					
Shaft diameter		=			20				

NR = Stainless steel
= Normal
VD = Fully sealed
DD = With two seals
D = 1 seal
= No seals

Standard linear bushings

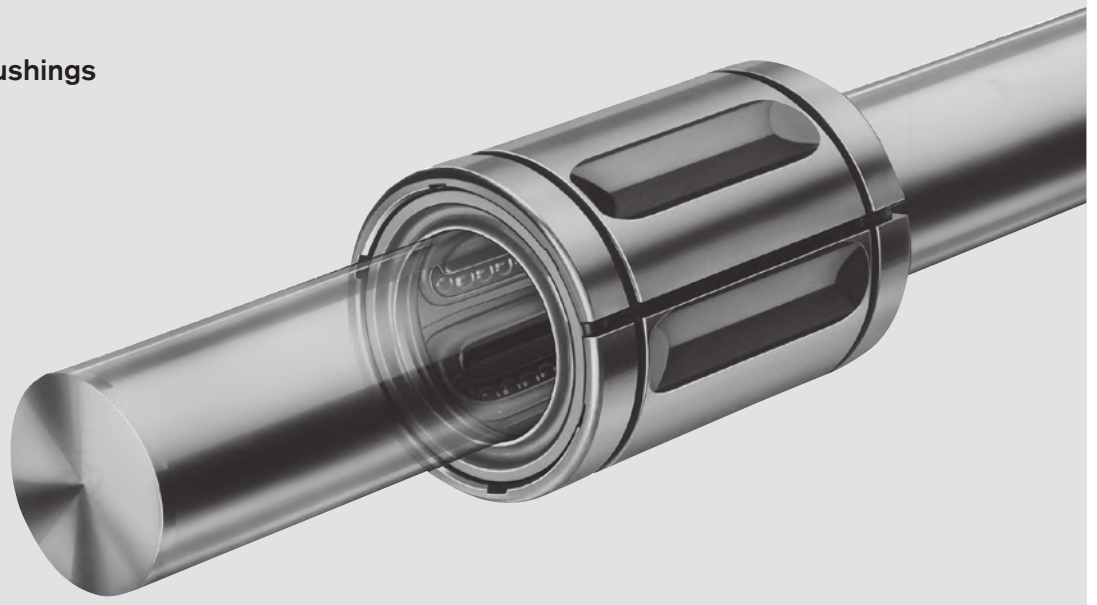

R1065 page 122

Closed



R1066 page 122

Adjustable



R1067 page 124

Open



R1068 page 124

Open, adjustable



R1071 page 126

Side opening



R1072 page 126

Side opening, adjustable



R1081 page 128

Flanged

Sample linear set:

Linear set with standard linear bushing
LSA-OE-M-20-DD

Definition of codes		LS	A	O	E	M	20	VD	
Type	Linear set = LS								
Material (housing)	Aluminum = A								
	Cast iron = G								
	Steel = S								
Form	Closed =								
	Open = O								
	Side opening = S								
	Adjustable = E								
	Flanged = F								
								VD = Fully sealed	Seals
								= No seals	
							20 =		Shaft diameter
							M = Standard (metal)		Series

Standard linear bushings

Technical data

Please observe general technical principles and follow the lubricating and installation instructions.

Installation dimensions/ interchangeability

Standard linear bushings have the same installation dimensions as super linear bushings. They are interchangeable, however differ in terms of securing, radial clearance, load ratings and lubrication.

Seal

Standard linear bushings come with a wiper seal with shaft diameters of 5 and higher. Open standard linear bushings with shaft diameters 20 to 80 can also come fully sealed (with linear seal; increased friction).

Friction

The friction coefficients μ of unsealed standard linear bushings are 0.001 – 0.004 when lubricated with oil.

The friction coefficient is lowest under high load. It can also be greater than the indicated value under low loads.

The table shows the friction generated by standard linear bushings with seals on both ends when not under radial load. They depend on speed and lubrication.

Shaft $\varnothing d$ (mm)	Closed and adjustable		Open	
	Breakaway force Reference value (N)	Friction Reference value (N)	Breakaway force Reference value (N)	Friction Reference value (N)
5	0.8	0.4	–	–
8	1.0	0.5	–	–
10	2.0	1.0	–	–
12	6.0	2.0	8	3
16	9.0	3.0	12	4
20	12.0	4.0	16	6
25	14.0	5.0	19	7
30	18.0	6.0	24	8
40	24.0	8.0	32	11
50	30.0	10.0	40	14
60	36.0	12.0	48	16
80	45.0	15.0	60	20

Speed and acceleration

$\varnothing d$ (mm)	v_{\max} (m/s)	a_{\max} (m/s ²)
≤ 40	2.5	100
≥ 50	2.0	50

Initial lubrication

Standard linear bushings do not have an initial lubrication. Grease linear bushings before use, see "Initial lubrication" section "Lubrication" on page 21. Service life data is based on initial lubrication and relubricated linear bushings.

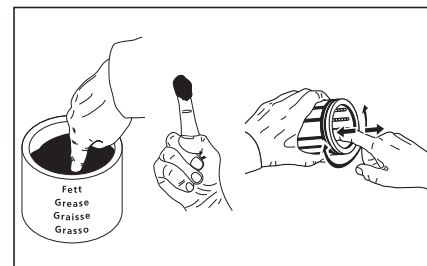

Operating temperatures

-10 °C to 80 °C

Only unsealed linear bushings with steel ball retainers may be used at higher temperatures. Note reductions in load rating (see "Life expectancy calculation" on page 16).

Impact of load direction on load rating of closed and adjustable standard linear bushings

Depending on installation, the listed load ratings should be chosen at the minimum or maximum position and should be based on the calculations.

If the load direction is clearly defined and the standard linear bushings can be installed at the maximum position, the load ratings C_{max} (dynamic load rating) and C_{0max} (static load rating) can be used.

If directed installation is not possible or the load direction is not defined, the minimum load ratings must be used.

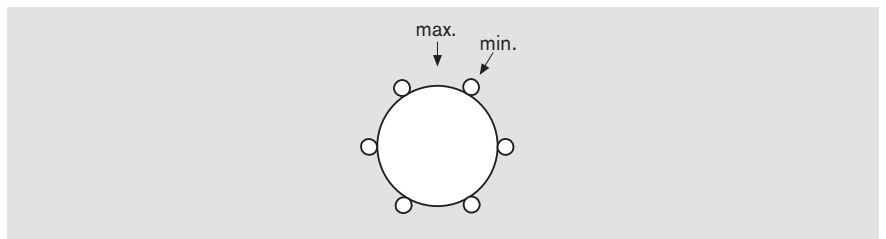

Impact of load direction on load rating of open standard linear bushings

The load ratings C and C_0 apply for the main load direction $\varrho = 0^\circ$. For all other load directions, the load ratings must be multiplied by the factors f_ϱ (dynamic load rating) or $f_{\varrho 0}$ (static load rating C_0).

Installing specific standard linear bushings can prevent a reduction in load rating (see linear set with side opening).



Load direction factors

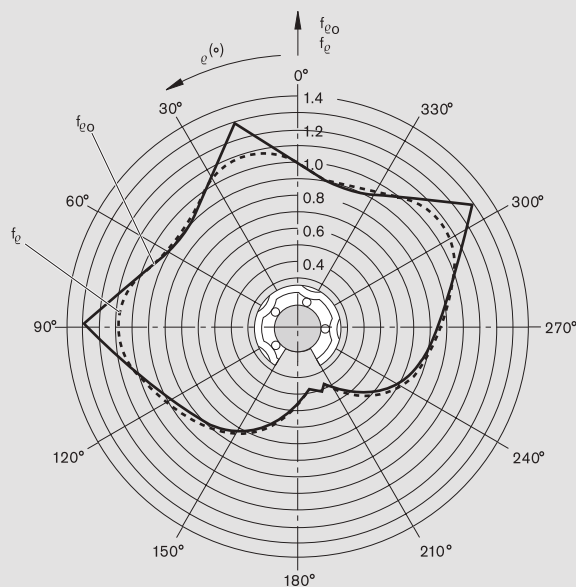

Shaft diameters 20 and 25

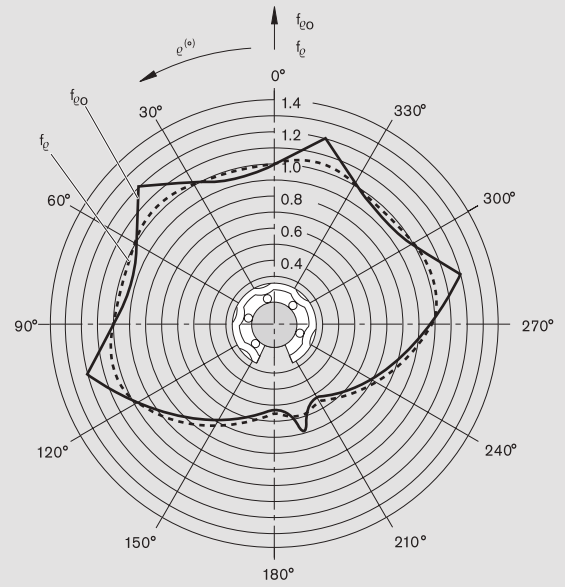

Shaft diameters 30 to 80

Standard linear bushings

Customer-built housings

Securing

Standard linear bushings, closed,
adjustable

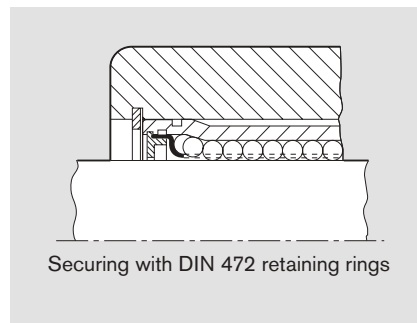
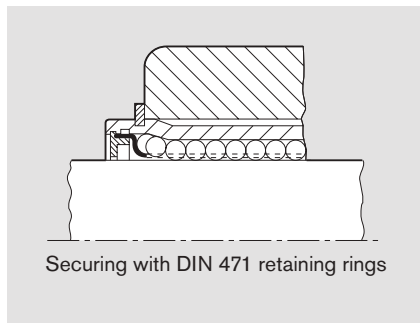

- Retaining rings
- Metal case
- Special design

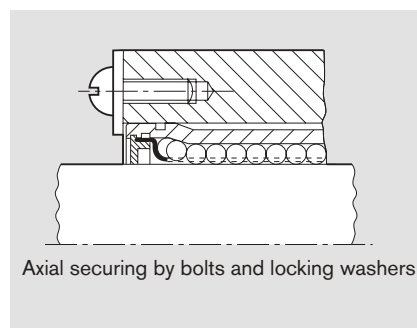
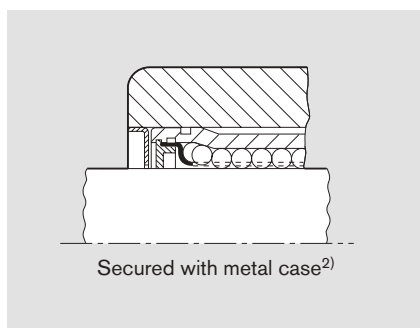

Shaft Ø d (mm)	DIN 471 retaining rings		DIN 472 retaining rings	
	Material number	Dimensions (mm)	Material number	Dimensions (mm)
5	R3410 712 00	12x1	R3410 207 00	12x1
8	R3410 713 00	16x1	R3410 208 00	16x1
10	R3410 763 00	19x1.2	R3410 221 00	19x1
12	R3410 714 00	22x1.2	R3410 209 00	22x1
16	R3410 715 00	27x1.2 ¹⁾	R3410 210 00	26x1.2
20	R3410 716 00	33x1.5 ¹⁾	R3410 211 00	32x1.2
25	R3410 717 00	42x1.75	R3410 212 00	40x1.75
30	R3410 718 00	48x1.75	R3410 213 00	47x1.75
40	R3410 719 00	62x2	R3410 214 00	62x2
50	R3410 720 00	75x2.5	R3410 215 00	75x2.5
60	R3410 721 00	90x3	R3410 216 00	90x3
80	R3410 722 00	120x4	R3410 217 00	120x4

1) Not in accordance with DIN 471.



2) See customer-built housings of super linear bushings  and  for material numbers and dimensions.

Standard linear bushings, open

– Locating hole dimensions

Open standard linear bushings come with a locating hole. It allows for axial and radial securing.

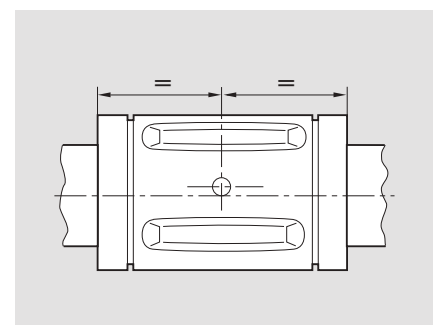
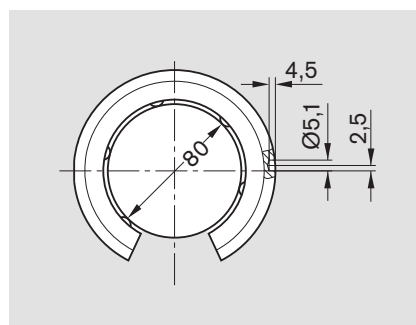
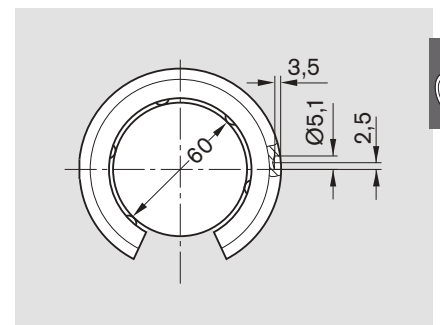
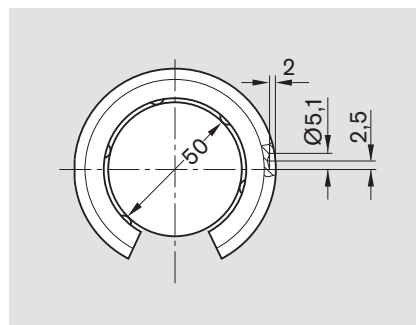
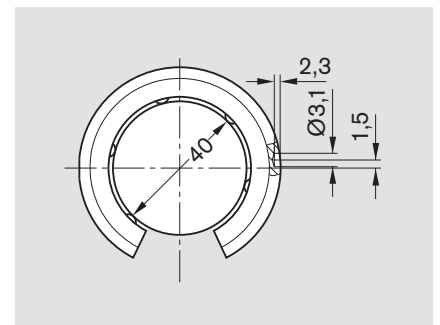
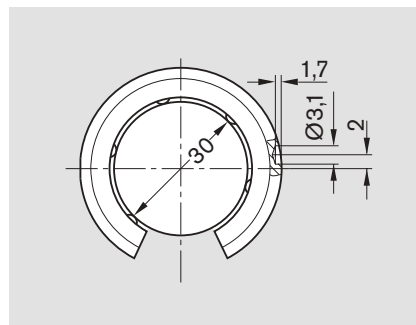
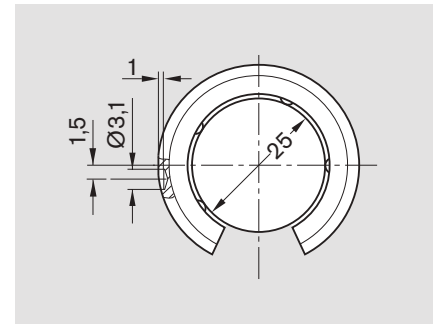
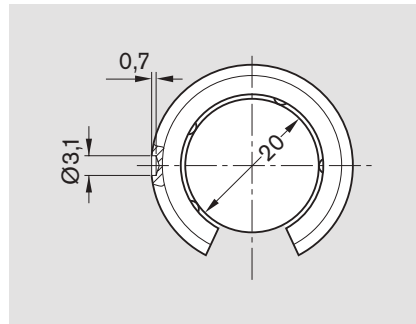

Standard linear bushings

Customer-built housings

– Secured with locating screw

Note on installation:

- Open standard linear bushings come with the necessary locating hole.
- During installation, the locating hole in the linear bushing is aligned with the pin hole in the housing. The locating screw is then screwed in and tightened to the specified torque.

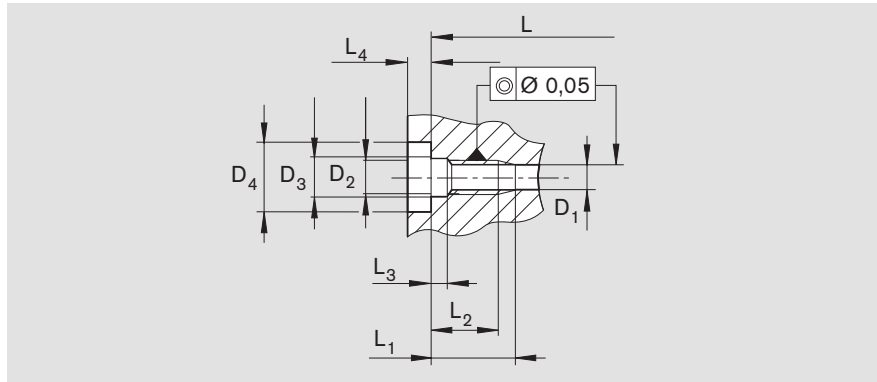
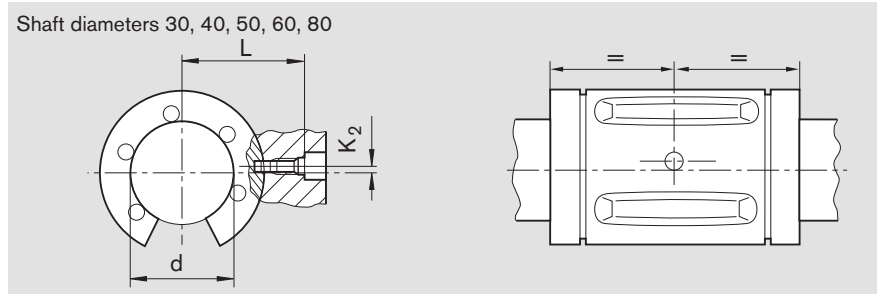
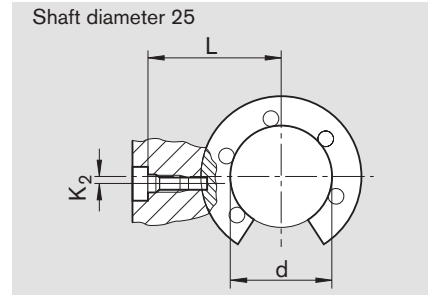
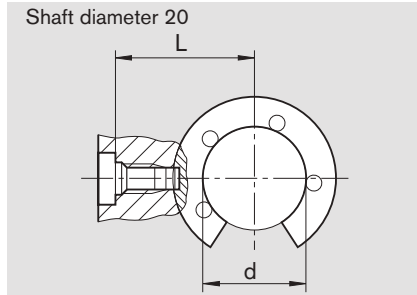

Locating screws

Locating screws are self-locking.

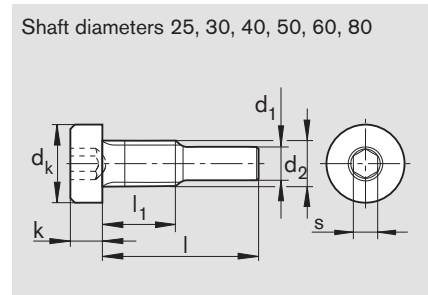
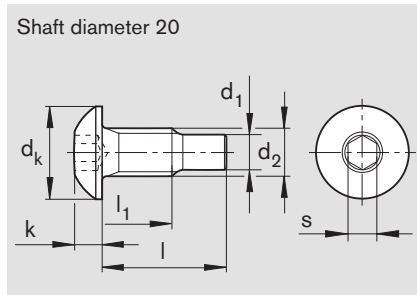

Shaft Ø d	Dimensions (mm)																Locating screw		Weight (g)	
	L	K ₂	L ₁	L ₂ min.	L ₃ +0.2	L ₄ min.	D ₁ +0.1	D ₂	D ₃ H13	D ₄ H13	d ₂	d _k	d ₁	l	l ₁	k	s	Material number		Tightening torque (Nm)
20	25.50 _{-0.10}	–	8.5 ^{+0.2}	6.5	1.3	2.5	3.1	M4	4.5	8	M4	7.6	3	10.15	5.7	2.2	2.5	R3429 009 01	1.9	1.4
25	33.05 _{-0.10}	1.5	10.0 ^{+0.2}	8.0	2.0	3.2	3.1	M4	4.5	8	M4	7.0	3	14.10	6.5	2.8	2.5	R3427 009 09	1.9	1.8
30	36.00 _{-0.15}	2.0	10.0 ^{+0.2}	8.0	2.0	3.2	3.1	M4	4.5	8	M4	7.0	3	14.10	6.5	2.8	2.5	R3427 009 09	1.9	1.8
40	42.90 _{-0.15}	1.5	10.0 ^{+0.2}	8.0	2.0	3.2	3.1	M4	4.5	8	M4	7.0	3	14.10	6.5	2.8	2.5	R3427 009 09	1.9	1.8
50	58.50 _{-0.20}	2.5	17.5 ^{+0.5}	13.5	3.7	6.0	5.1	M8	9.0	15	M8	13.0	5	22.80	12.5	5.0	5.0	R3427 005 09	16.0	11.1
60	71.50 _{-0.25}	2.5	17.5 ^{+0.5}	13.5	3.7	6.0	5.1	M8	9.0	15	M8	13.0	5	29.70	12.5	5.0	5.0	R3427 006 09	16.0	12.2
80	85.50 _{-0.25}	2.5	17.5 ^{+0.5}	13.5	3.7	6.0	5.1	M8	9.0	15	M8	13.0	5	29.70	12.5	5.0	5.0	R3427 006 09	16.0	12.2

- Axial securing by bolts and locking washers, as well as torsional securing with pin or washers.

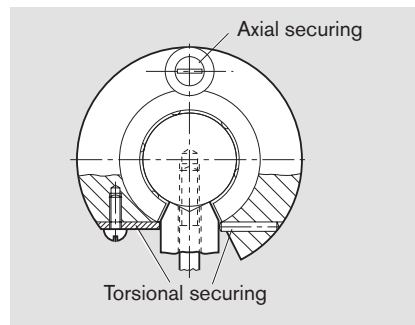

Standard linear bushings

**Standard linear bushings,
R0600 closed, no wiper seals****Standard linear bushings,
R0602 closed, with wiper seals****Design**

- Hardened and machined outer sleeve
- Steel ball retainer (shaft diameters 3 to 10 with plastic ball retainer made of POM¹⁾ or PA²⁾)
- Balls made of rolling bearing steel
- No wiper seals, come with integrated steel retaining rings; higher temperatures allowed with shaft diameters 12 and higher
- Integrated wiper seals for high contamination
- Closed, for self-supporting shafts



Shaft Ø d (mm)	Material number		Weight (kg)
	No wiper seal KBM- ...	With two wiper seals KBM- ... -DD	
3 ¹⁾	R0600 303 00	–	0.001
4 ¹⁾	R0600 304 00	–	0.002
5 ²⁾	R0600 305 00	R0602 305 10	0.010
8 ²⁾	R0600 308 00	R0602 308 10	0.020
10 ¹⁾	R0600 310 00	R0602 310 10	0.030
12	R0600 012 00	R0602 012 10	0.040
16	R0600 016 00	R0602 016 10	0.050
20	R0600 020 00	R0602 020 10	0.100
25	R0600 025 00	R0602 025 10	0.190
30	R0600 030 00	R0602 030 10	0.320
40	R0600 040 00	R0602 040 10	0.620
50	R0600 050 00	R0602 050 10	1.140
60	R0600 060 00	R0602 060 10	2.110
80	R0600 080 00	R0602 080 10	4.700

With 1 wiper seal: R0601 ... 10.

Explanation of sample short product name

KB	M	12	DD
Linear bushing	Standard (metal)	Ø 12	With two seals

See page 96 for more information on short product names.

Dimensions

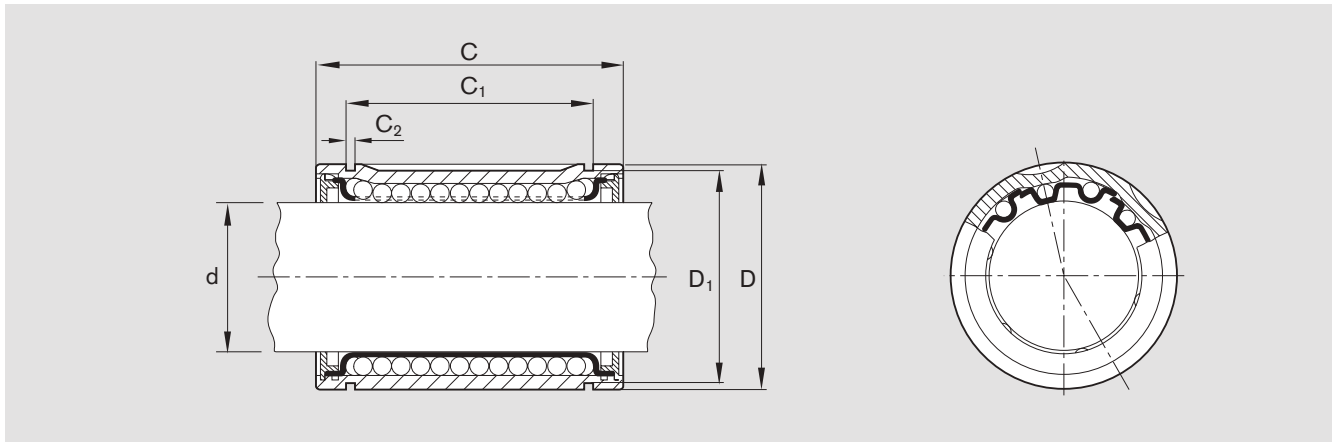

Dimensions (mm)						Rows of balls	Working bore diameter tolerance (µm)	Radial clearance ¹⁾ h6 shaft (µm)	Load ratings (N)			
Ø d	D	C h12	C ₁ H13	C ₂	D ₁				min.	dyn. C max.	min.	stat. C ₀ max.
3	7	10	-	-	-	4	+8 0	+12 +2	55	65	45	65
4	8	12	-	-	-	4	+8 0	+14 +2	70	80	60	85
5	12	22	14.2	1.1	11.1	4	+11 +1	+16 +4	180	210	140	200
8	16	25	16.2	1.1	14.7	4	+12 +2	+18 +5	320	370	240	330
10	19	29	21.6	1.3	18.0	4	+8 0	+18 +5	300	350	260	370
12	22	32	22.6	1.3	20.5	4	+12 +2	+20 +5	420	480	280	400
16	26	36	24.6	1.3	24.9	4	+14 +2	+22 +5	580	670	440	620
20	32	45	31.2	1.6	30.5	5	+14 +2	+23 +6	1,170	1,390	860	1,250
25	40	58	43.7	1.85	38.5	5	+16 +2	+25 +6	2,080	2,480	1,560	2,280
30	47	68	51.7	1.85	44.5	6	+16 +2	+25 +6	2,820	2,980	2,230	2,860
40	62	80	60.3	2.15	58.0	6	+19 +2	+30 +7	5,170	5,480	3,810	4,880
50	75	100	77.3	2.65	71.0	6	+19 +2	+30 +7	8,260	8,740	6,470	8,280
60	90	125	101.3	3.15	85.0	6	+19 +2	+33 +7	11,500	12,100	9,160	11,730
80	120	165	133.3	4.15	114.0	6	+24 +2	+37 +8	21,000	22,200	16,300	20,850

1) Determined from working bore diameter and shaft tolerance statistics. Recommended housing bore tolerance: H6 or H7.

The dynamic load ratings are based on a total travel of 100,000 m.
When based on 50,000 m, the C values in the table are multiplied by 1.26.



Standard linear bushings

Standard linear bushings, R0600 Closed, no wiper seal stainless

Standard linear bushings, R0602 Closed, with wiper seals stainless

Design

- Hardened and machined outer sleeve made of stainless steel comparable to 1.4125
- Ball retainer made of stainless steel comparable to 1.4301
- Balls made of stainless steel comparable to 1.4125
- Integrated retaining rings made of stainless steel comparable to 1.4006 or wiper seals
- Closed, for self-supporting shafts



Shaft Ø d (mm)	Material number		Weight (kg)
	No wiper seal KBM- ... -NR	With two wiper seals KBM- ... -DD-NR	
3	R0600 003 30	–	0.001
4	R0600 004 30	–	0.002
5	R0600 005 30	R0602 005 30	0.011
8	R0600 008 30	R0602 008 30	0.022
10	R0600 010 30	R0602 010 30	0.036
12	R0600 012 30	R0602 012 30	0.045
16	R0600 016 30	R0602 016 30	0.060
20	R0600 020 30	R0602 020 30	0.100
25	R0600 025 30	R0602 025 30	0.235
30	R0600 030 30	R0602 030 30	0.360
40	R0600 040 30	R0602 040 30	0.770

Explanation of sample short product name

KB	M	12	DD	NR
Linear bushing	Standard (metal)	Ø 12	With two seals	Stainless steel

See page 96 for more information on short product names.

Dimensions

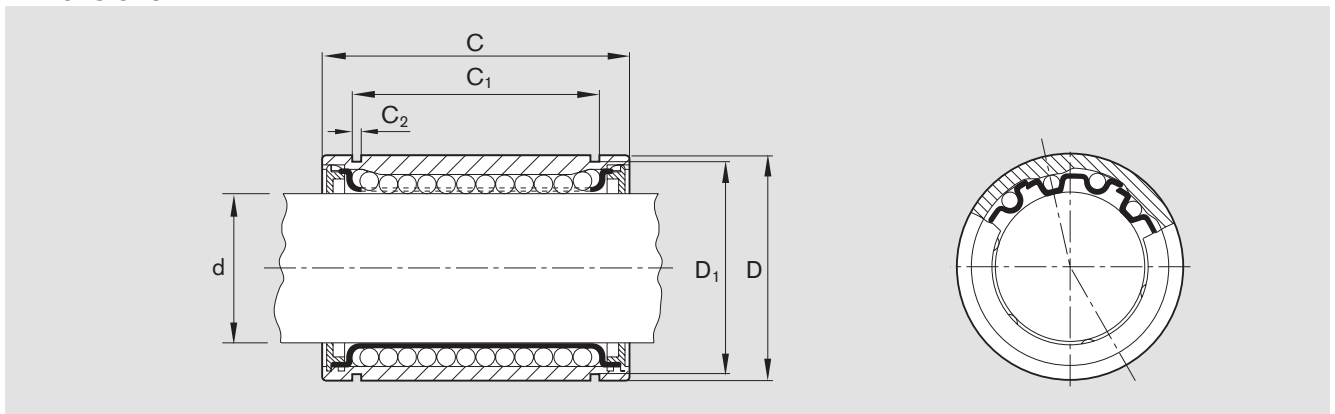

Dimensions (mm)						Rows of balls	Working bore diameter tolerance (µm)	Radial clearance ¹⁾ h6 shaft (µm)	Load ratings (N)			
Ø d	D	C h12	C ₁ H13	C ₂	D ₁				min.	dyn. C max.	min.	stat. C ₀ max.
3	7	10	-	-	-	4	+8 0	+12 +2	55	65	45	65
4	8	12	-	-	-	4	+8 0	+14 +2	70	80	60	85
5	12	22	14.2	1.10	11.5	4	+11 +1	+16 +4	160	185	180	250
8	16	25	16.2	1.10	15.2	4	+12 +2	+18 +5	210	240	235	330
10	19	29	21.6	1.30	18.0	4	+8 0	+18 +5	300	350	260	370
12	22	32	22.6	1.30	21.0	4	+12 +2	+20 +5	400	460	420	600
16	26	36	24.6	1.30	24.9	4	+14 +2	+22 +5	460	530	440	630
20	32	45	31.2	1.60	30.3	5	+14 +2	+23 +6	680	800	860	1,250
25	40	58	43.7	1.85	37.5	6	+16 +2	+25 +6	780	830	1,620	2,100
30	47	68	51.7	1.85	44.5	6	+16 +2	+25 +6	1,250	1,320	2,000	2,500
40	62	80	60.3	2.15	59.0	6	+19 +2	+30 +7	1,720	1,820	3,300	4,200

1) Determined from working bore diameter and shaft tolerance statistics. Recommended housing bore tolerance: H6 or H7.

The dynamic load ratings are based on a total travel of 100,000 m.

When based on 50,000 m, the C values in the table are multiplied by 1.26.



Standard linear bushings

Standard linear bushings, R0610 adjustable, no wiper seals

Standard linear bushings, R0612 adjustable, with wiper seals

Design

- Hardened and machined outer sleeve
- Steel ball retainer (shaft diameters 5 and 8 with plastic retainer made of PA¹⁾)
- Balls made of rolling bearing steel
- No wiper seals, come with integrated steel retaining rings; higher temperatures allowed with shaft diameters 12 and higher
- Integrated wiper seals for high contamination
- Radial clearance adjustable



Shaft Ø d (mm)	Material number		Weight (kg)
	No wiper seal KBM-E- ...	With two wiper seals KBM-E- ... -DD	
5 ¹⁾	R0610 305 00	R0612 305 10	0.01
8 ¹⁾	R0610 308 00	R0612 308 10	0.02
12	R0610 012 00	R0612 012 10	0.04
16	R0610 016 00	R0612 016 10	0.05
20	R0610 020 00	R0612 020 10	0.10
25	R0610 025 00	R0612 025 10	0.19
30	R0610 030 00	R0612 030 10	0.32
40	R0610 040 00	R0612 040 10	0.62
50	R0610 050 00	R0612 050 10	1.14
60	R0610 060 00	R0612 060 10	2.11
80	R0610 080 00	R0612 080 10	4.70

With 1 wiper seal: R0611 ... 10.

Explanation of sample short product name

KB	M	E	12	DD
Linear bushing	Standard (metal)	Adjustable	Ø 12	With two seals

See page 96 for more information on short product names.

Dimensions

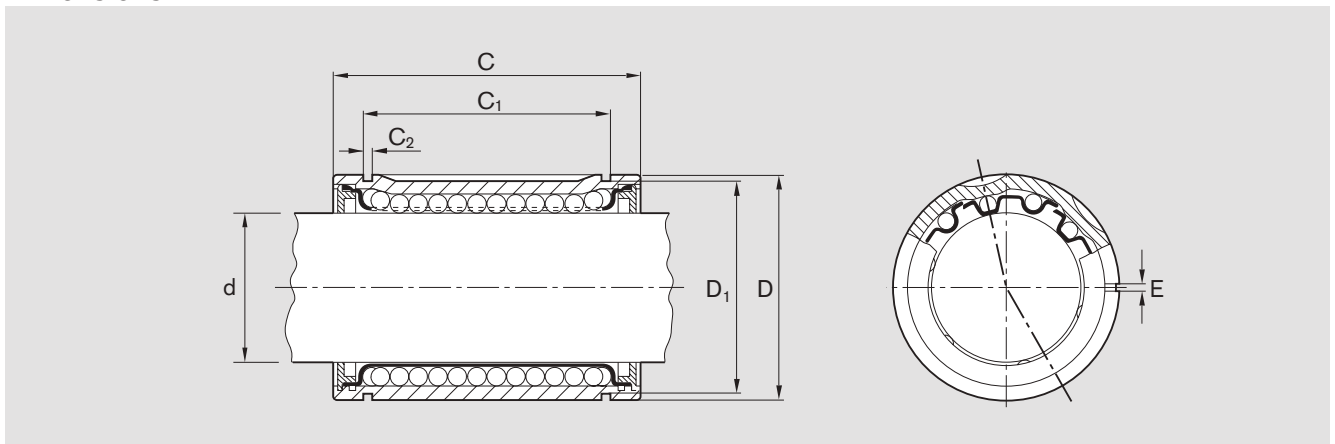

Dimensions (mm)							Rows of balls	Load ratings (N)				Radial clearance (μm)	
$\varnothing d$	D	C h12	C_1 H13	C_2	D_1	E		min.	dyn. C max.	min.	stat. C_0 max.	Shaft/bore h6/H7	h6/K7
5	12	22	14.2	1.10	11.1	1.5	4	180	210	140	200	+34 +11	+22 -1
8	16	25	16.2	1.10	14.7	1.5	4	320	370	240	330	+36 +13	+24 +1
12	22	32	22.6	1.30	20.5	1.5	4	420	480	280	400	+41 +14	+26 -1
16	26	36	24.6	1.30	24.9	1.5	4	580	670	440	620	+43 +14	+28 -1
20	32	45	31.2	1.60	30.5	2.0	5	1,170	1,390	860	1,250	+49 +16	+31 -2
25	40	58	43.7	1.85	38.5	2.0	5	2,080	2,480	1,560	2,280	+50 +17	+32 -1
30	47	68	51.7	1.85	44.5	2.0	6	2,820	2,980	2,230	2,860	+50 +17	+32 -1
40	62	80	60.3	2.15	58.0	2.0	6	5,170	5,480	3,810	4,880	+60 +20	+39 -1
50	75	100	77.3	2.65	71.0	2.0	6	8,260	8,740	6,470	8,280	+60 +20	+39 -1
60	90	125	101.3	3.15	85.0	2.0	6	11,500	12,100	9,160	11,730	+68 +22	+43 -3
80	120	165	133.3	4.15	114.0	2.0	6	21,000	22,200	16,300	20,850	+71 +24	+46 -1

The dynamic load ratings are based on a total travel of 100,000 m.
When based on 50,000 m, the C values in the table are multiplied by 1.26.



Standard linear bushings

**Standard linear bushings,
R0630 Open, no wiper seals**

**Standard linear bushings,
R0632 Open, with wiper seals**

Design

- Hardened and machined outer sleeve
- Steel ball retainer
- Balls made of rolling bearing steel
- No wiper seals, come with integrated steel retaining rings; higher temperatures allowed with shaft diameters 12 and higher
- Integrated wiper seals for high contamination
- With locating hole for axial and radial securing (no locating hole for shaft diameters 12 and 16)



Shaft Ø d (mm)	Material number			Weight (kg)
	No wiper seal KBM-O- ...	2 wiper seals KBM-O- ... -DD	Fully sealed KBM-O- ... -VD	
12 ¹⁾	R0630 012 00	R0632 012 00	-	0.03
16 ¹⁾	R0630 016 00	R0632 016 00	-	0.04
20	R0630 020 00	R0632 020 00	R0632 020 05	0.08
25	R0630 025 00	R0632 025 00	R0632 025 05	0.15
30	R0630 030 00	R0632 030 00	R0632 030 05	0.26
40	R0630 040 00	R0632 040 00	R0632 040 05	0.52
50	R0630 050 00	R0632 050 00	R0632 050 05	0.95
60	R0630 060 00	R0632 060 00	R0632 060 05	1.76
80	R0630 080 00	R0632 080 00	R0632 080 05	3.92

1) No locating hole for radial and axial securing.

With 1 wiper seal: R0631 0.. 00.

Explanation of sample short product name

KB	M	O	12	DD
Linear bushing	Standard (metal)	Open	Ø 12	With two seals

See page 96 for more information on short product names.

Dimensions

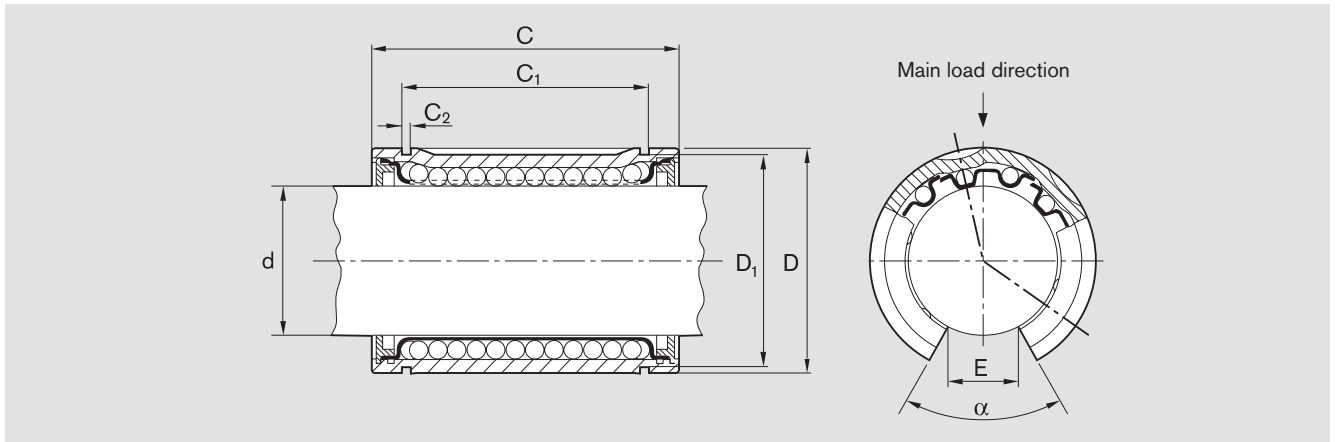

Dimensions (mm)							Angle α (°)	Rows of balls	Load ratings ²⁾ (N)		Radial clearance (μm)	
$\varnothing d$	D	C h12	C ₁ H13	C ₂	D ₁	E ¹⁾			dyn. C	stat. C ₀	Shaft/bore h6/H7	h6/K7
12	22	32	22.6	1.30	20.5	7.5	78	3	430	290	+41 +14	+26 -1
16	26	36	24.6	1.30	24.9	10.0	78	3	600	450	+43 +14	+28 -1
20	32	45	31.2	1.60	30.5	10.0	60	4	1,280	970	+49 +16	+31 -2
25	40	58	43.7	1.85	38.5	12.5	60	4	2,270	1,750	+50 +17	+32 -1
30	47	68	51.7	1.85	44.5	12.5	50	5	2,890	2,390	+50 +17	+32 -1
40	62	80	60.3	2.15	58.0	16.8	50	5	5,280	4,000	+60 +20	+39 -1
50	75	100	77.3	2.65	71.0	21.0	50	5	8,470	6,900	+60 +20	+39 -1
60	90	125	101.3	3.15	85.0	27.2	54	5	11,800	9,780	+68 +22	+43 -3
80	120	165	133.3	4.15	114.0	36.3	54	5	21,500	17,400	+71 +24	+46 -1

- 1) Minimum size in relation to $\varnothing d$.
- 2) The load ratings C and C₀ apply for the main load direction.

The dynamic load ratings are based on a total travel of 100,000 m.
When based on 50,000 m, the C values in the table are multiplied by 1.26.

⚠ Refer to the diagrams on page 99 for load in the direction of opening.

Shaft diameters 12 and 16 must be installed as shown (inversely) in order to avoid lifting off the shaft. It is not possible to set a single linear bushing (slotted housing with adjusting screw) to zero clearance.

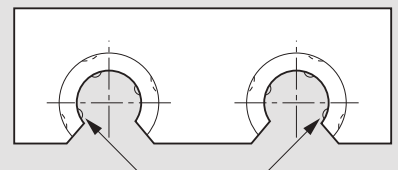

Standard linear bushings

Standard linear bushings, R0650 Tandem, with wiper seals Normal

Design

- Hardened and machined outer sleeve
- POM ball retainer
- Balls made of rolling bearing steel
- Integrated wiper seals

Standard linear bushings, R0650 Tandem, with wiper seals Stainless

Design

- Hardened and machined outer sleeve made of stainless steel comparable to 1.4125
- Ball retainer made of stainless steel comparable to 1.4301
- Balls made of stainless steel comparable to 1.4125 Retaining rings for ball retainer made of stainless steel comparable to 1.4006
- Integrated wiper seals



Shaft Ø d (mm)	Material number		Weight (kg)
	Normal KBMT- ... -DD	Stainless KBMT- ... -DD-NR	
8	R0650 508 00	R0650 208 30	0.04
12	R0650 512 00	R0650 212 30	0.08
16	R0650 516 00	R0650 216 30	0.12
20	R0650 520 00	R0650 220 30	0.18
25	R0650 525 00	R0650 225 30	0.43
30	R0650 530 00	R0650 230 30	0.62
40	R0650 540 00	R0650 240 30	1.40

Explanation of sample short product name

KB	M	T	12	DD	NR
Linear bushing	Standard (metal)	Tandem	Ø 12	With two seals	Stainless steel

See page 96 for more information on short product names.

Dimensions

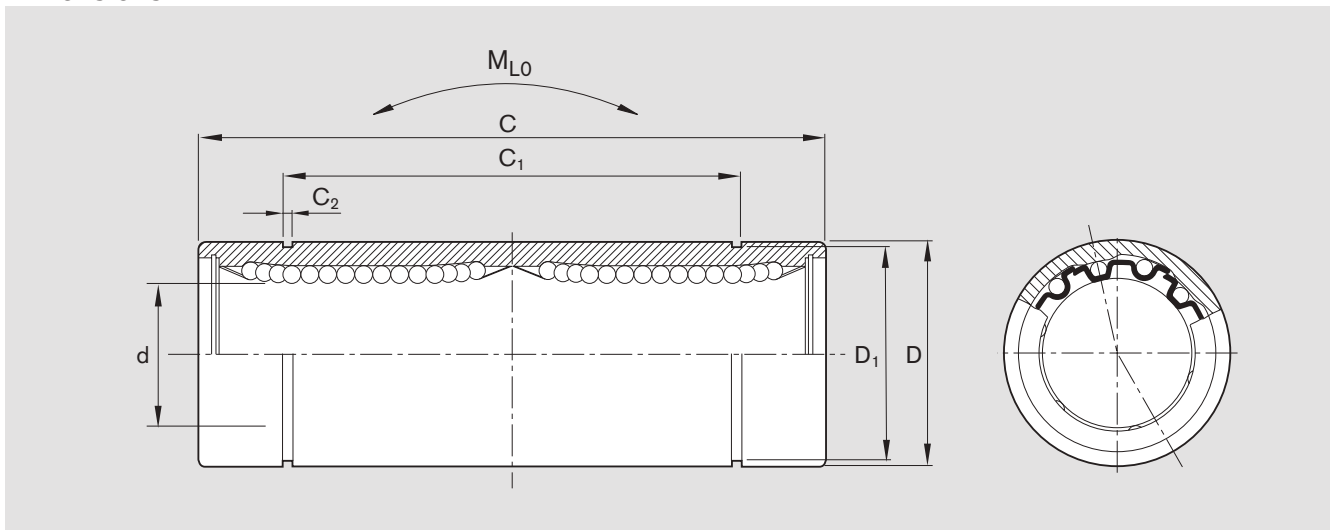

Dimensions (mm)						Rows of balls	Working bore diameter tolerance (μm)	Radial clearance ¹⁾ h6 shaft (μm)	Load ratings (N)				Linear torque M_{L0} (Nm)
$\varnothing d$	D	C	C_1	C_2	D_1				min.	dyn. C max.	min.	stat. C_0 max.	
8	16	46 _{-0.3}	33.0 _{-0.3}	1.10	15.2	4	+9 -1	+15 +2	340	390	470	660	4.5
12	22	61 _{-0.3}	45.8 _{-0.3}	1.30	21.0	4	+9 -1	+17 +2	650	750	840	1,200	11.0
16	26	68 _{-0.3}	49.8 _{-0.3}	1.30	24.9	4	+11 -1	+19 +2	750	860	880	1,260	13.0
20	32	80 _{-0.3}	61.0 _{-0.3}	1.60	30.5	5	+11 -1	+20 +3	1,100	1,300	1,720	2,500	26.0
25	40	112 _{-0.4}	82.0 _{-0.4}	1.85	38.0	6	+13 -2	+22 +2	1,250	1,350	3,240	4,200	61.0
30	47	123 _{-0.4}	104.2 _{-0.4}	1.85	44.5	6	+13 -2	+22 +2	2,000	2,150	4,000	5,000	82.0
40	62	151 _{-0.4}	121.2 _{-0.4}	2.15	59.0	6	+16 -4	+27 +1	2,800	3,000	6,600	8,400	165.0

1) Determined from working bore diameter and shaft tolerance statistics. Recommended housing bore tolerance: H6 or H7.

The dynamic load ratings are based on a total travel of 100,000 m.
When based on 50,000 m, the C values in the table are multiplied by 1.26.



Standard linear bushings

Standard linear bushings, R0740 Flanged Normal

Design

- Hardened and machined outer sleeve
- POM ball retainer
- Balls made of rolling bearing steel
- Integrated wiper seals

Standard linear bushings, R0740 Flanged Stainless

Design

- Hardened and machined outer sleeve made of stainless steel comparable to 1.4125
- Ball retainer made of stainless steel comparable to 1.4301, made of POM for shaft diameter 5
- Balls made of stainless steel comparable to 1.4125
- Flange and retaining rings for ball retainer made of stainless steel comparable to 1.4006
- Integrated wiper seals



Shaft Ø d (mm)	Material number		Weight (kg)
	Normal KBMF- ... -DD	Stainless KBMF- ... -DD-NR	
5	R0740 505 00	R0740 505 30	0.020
8	R0740 508 00	R0740 208 30	0.033
12	R0740 512 00	R0740 212 30	0.064
16	R0740 516 00	R0740 216 30	0.090
20	R0740 520 00	R0740 220 30	0.150
25	R0740 525 00	R0740 225 30	0.300
30	R0740 530 00	R0740 230 30	0.470
40	R0740 540 00	R0740 240 30	0.980

Explanation of sample short product name

KB	M	F	12	DD	NR
Linear bushing	Standard (metal)	Flanged	Ø 12	With two seals	Stainless steel

See page 96 for more information on short product names.

Dimensions

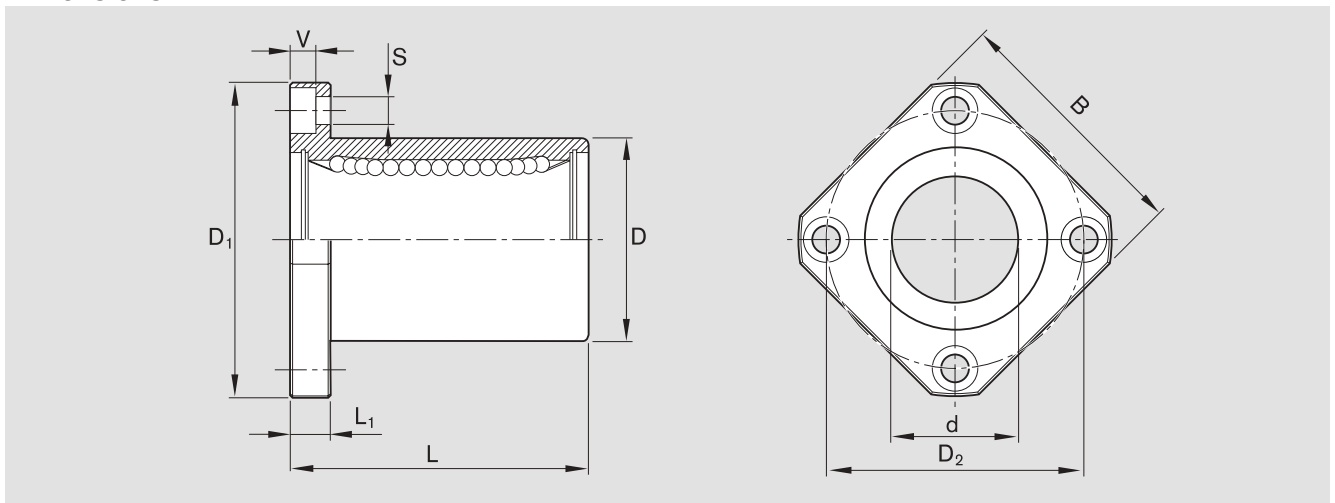

Dimensions (mm)										Working bore diameter tolerance (µm)	Radial clearance ¹⁾ h6 shaft (µm)	Load ratings (N)			
Ø d	D	D ₁	D ₂	B	L	L ₁	V	S	Rows of balls			dyn. C		stat. C ₀	
					±0.3							min.	max.	min.	max.
5	12 _{-0.013}	28	20	22	22	5	3.1	3.5	4	+8 +0	+14 +2	160	185	180	250
8	16 _{-0.013}	32	24	25	25	5	3.1	3.5	4	+8 +0	+15 +2	210	240	235	330
12	22 _{-0.016}	42	32	32	32	6	4.1	4.5	4	+8 +0	+16 +3	400	460	420	600
16	26 _{-0.016}	46	36	35	36	6	4.1	4.5	4	+9 -1	+17 +2	460	530	440	630
20	32 _{-0.019}	54	43	42	45	8	5.1	5.5	5	+9 -1	+19 +2	680	800	860	1,250
25	40 _{-0.019}	62	51	50	58	8	5.1	5.5	6	+11 -1	+20 +3	780	830	1,620	2,100
30	47 _{-0.019}	76	62	60	68	10	6.1	6.6	6	+11 -1	+20 +3	1,250	1,320	2,000	2,500
40	62 _{-0.022}	98	80	75	80	13	8.1	9.0	6	+13 -2	+24 +3	1,720	1,820	3,300	4,200

1) Determined from working bore diameter and shaft tolerance statistics. Recommended housing bore tolerance: H6 or H7.

The dynamic load ratings are based on a total travel of 100,000 m.
When based on 50,000 m, the C values in the table are multiplied by 1.26.



Standard linear bushings

Standard linear bushings, R0741 Flanged tandem Normal

Design

- Hardened and machined outer sleeve
- POM ball retainer
- Balls made of rolling bearing steel
- Integrated wiper seals

Standard linear bushings, R0741 Flanged tandem Stainless

Design

- Hardened and machined outer sleeve made of stainless steel comparable to 1.4125
- Ball retainer made of stainless steel comparable to 1.4301, made of POM for shaft diameter 5
- Balls made of stainless steel comparable to 1.4125
- Retaining rings for ball retainer made of stainless steel comparable to 1.4006
- Flange made of stainless steel comparable to 1.4006
- Integrated wiper seals



Shaft Ø d (mm)	Material number		Weight (kg)
	Normal KBMFT- ... -DD	Stainless KBMFT- ... -DD-NR	
8	R0741 508 00	R0741 208 30	0.05
12	R0741 512 00	R0741 212 30	0.09
16	R0741 516 00	R0741 216 30	0.14
20	R0741 520 00	R0741 220 30	0.23
25	R0741 525 00	R0741 225 30	0.50
30	R0741 530 00	R0741 230 30	0.72
40	R0741 540 00	R0741 240 30	1.60

Explanation of sample short product name

KB	M	FT	12	DD	NR
Linear bushing	Standard (metal)	Flanged, tandem	Ø 12	With two seals	Stainless steel

See page 96 for more information on short product names.

Dimensions

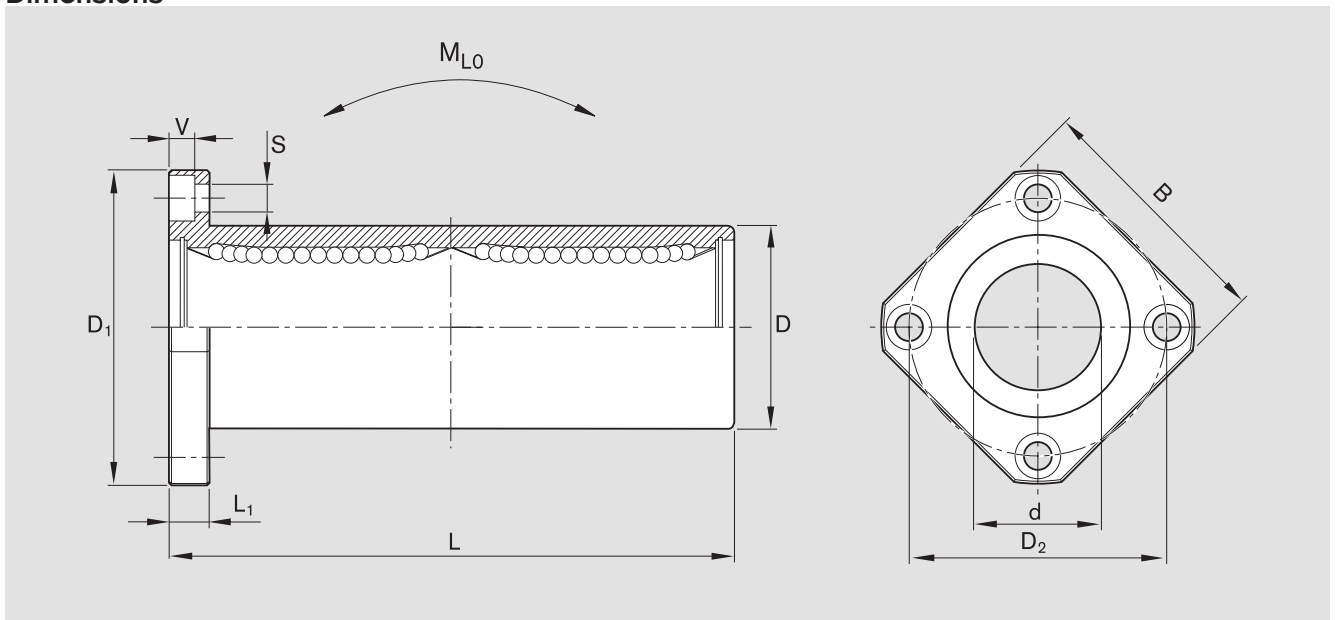

Ø d	Dimensions (mm)								Rows of balls	Working bore diameter tolerance (µm)	Radial clearance ¹⁾ h6 shaft (µm)	Load ratings (N)				Linear torque M _{L0} (Nm)
	D	D ₁	D ₂	B	L	L ₁	V	S				dyn. C		stat. C ₀		
					±0.3						min.	max.	min.	max.		
8	16 _{-0.013}	32	24	25	46	5	3.1	3.5	4	+9 -1	+15 +2	340	390	470	660	4.5
12	22 _{-0.016}	42	32	32	61	6	4.1	4.5	4	+9 -1	+17 +2	650	750	840	1,200	11
16	26 _{-0.016}	46	36	35	68	6	4.1	4.5	4	+11 -1	+19 +2	750	860	880	1,260	13
20	32 _{-0.019}	54	43	42	80	8	5.1	5.5	5	+11 -1	+20 +3	1,100	1,300	1,720	2,500	26
25	40 _{-0.019}	62	51	50	112	8	5.1	5.5	6	+13 -2	+22 +2	1,250	1,350	3,240	4,200	61
30	47 _{-0.019}	76	62	60	123	10	6.1	6.6	6	+13 -2	+22 +2	2,000	2,150	4,000	5,000	82
40	62 _{-0.022}	98	80	75	151	13	8.1	9.0	6	+16 -4	+27 +1	2,800	3,000	6,600	8,400	165

1) Determined from working bore diameter and shaft tolerance statistics. Recommended housing bore tolerance: H6 or H7.

The dynamic load ratings are based on a total travel of 100,000 m.
When based on 50,000 m, the C values in the table are multiplied by 1.26.



Standard linear bushings

Standard linear bushings, R0742 Center flanged Normal

Design

- Hardened and machined outer sleeve
- POM ball retainer
- Balls made of rolling bearing steel
- Integrated wiper seals

Standard linear bushings, R0742 Center flanged Stainless

Design

- Hardened and machined outer sleeve made of stainless steel comparable to 1.4125
- Ball retainer made of stainless steel comparable to 1.4301
- Balls made of stainless steel comparable to 1.4125
- Flange made of stainless steel comparable to 1.4006
- Integrated wiper seals



Shaft Ø d (mm)	Material number		Weight (kg)
	Normal KBMM- ... -DD	Stainless KBMM- ... -DD-NR	
8	R0742 508 00	R0742 208 30	0.05
12	R0742 512 00	R0742 212 30	0.09
16	R0742 516 00	R0742 216 30	0.14
20	R0742 520 00	R0742 220 30	0.23
25	R0742 525 00	R0742 225 30	0.50
30	R0742 530 00	R0742 230 30	0.72
40	R0742 540 00	R0742 240 30	1.60

Explanation of sample short product name

KB	M	M	12	DD	NR
Linear bushing	Standard (metal)	Central flanged	Ø 12	With two seals	Stainless steel

See page 96 for more information on short product names.

Dimensions

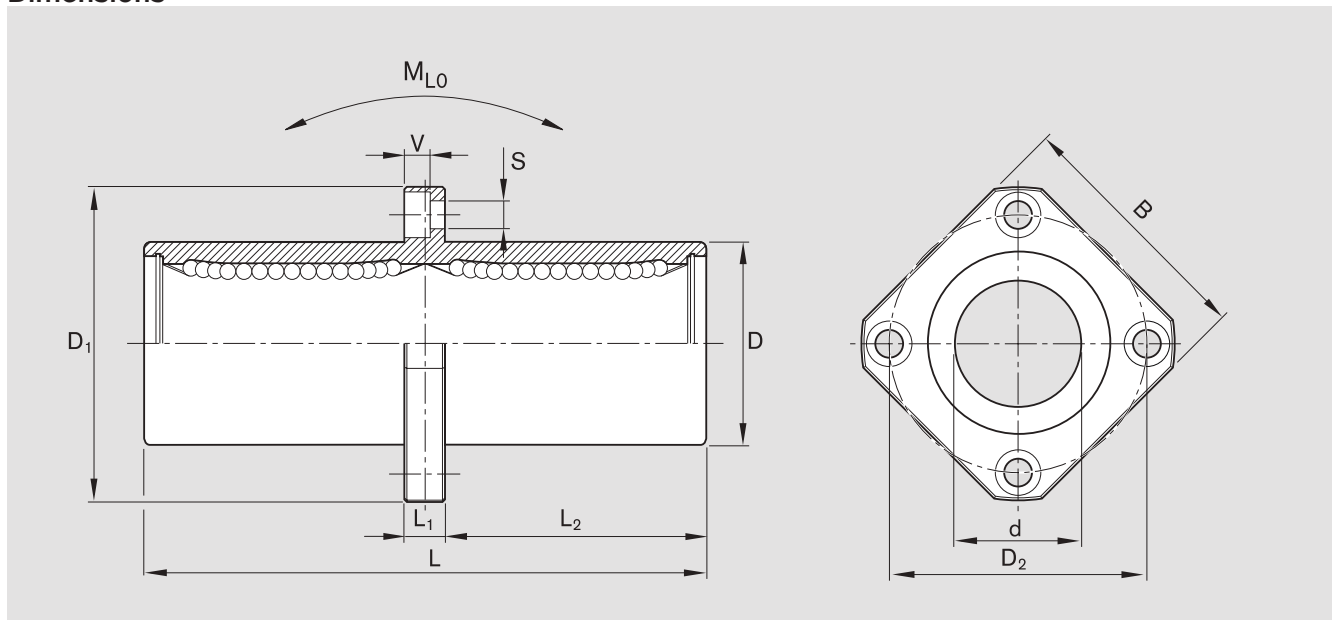

Ø d	Dimensions (mm)										Rows of balls	Working bore diameter tolerance (µm)	Radial clearance ¹⁾ h6 shaft (µm)	Load ratings (N)				Linear torque M_{L0} (Nm)
	D	D ₁	D ₂	B	L	L ₁	L ₂	V	S	dyn. C				stat. C ₀				
					±0.3								min.	max.	min.	max.		
8	16 _{-0.013}	32	24	25	46	5	20.5	3.1	3.5	4	+9 -1	+15 +2	340	390	470	660	4.5	
12	22 _{-0.016}	42	32	32	61	6	27.5	4.1	4.5	4	+9 -1	+17 +2	650	750	840	1,200	11	
16	26 _{-0.016}	46	36	35	68	6	31.0	4.1	4.5	4	+11 -1	+19 +2	750	860	880	1,260	13	
20	32 _{-0.019}	54	43	42	80	8	36.0	5.1	5.5	5	+11 -1	+20 +3	1,100	1,300	1,720	2,500	26	
25	40 _{-0.019}	62	51	50	112	8	52.0	5.1	5.5	6	+13 -2	+22 +2	1,250	1,350	3,240	4,200	61	
30	47 _{-0.019}	76	62	60	123	10	56.5	6.1	6.6	6	+13 -2	+22 +2	2,000	2,150	4,000	5,000	82	
40	62 _{-0.022}	98	80	75	151	13	69.0	8.1	9.0	6	+16 -4	+27 +1	2,800	3,000	6,600	8,400	165	

1) Determined from working bore diameter and shaft tolerance statistics. Recommended housing bore tolerance: H6 or H7.

The dynamic load ratings are based on a total travel of 100,000 m.
When based on 50,000 m, the C values in the table are multiplied by 1.26.



Linear sets with standard linear bushings

Overview

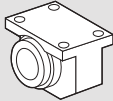
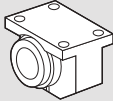
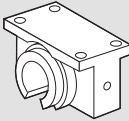
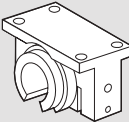
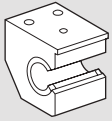
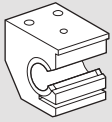
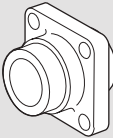
	Linear sets Standard linear bushings	
	Aluminum housing	Cast iron/steel housing
<p>Closed Standard version with fixed working bore diameter.</p>		<p>R1065</p> 
<p>Adjustable For zero-clearance or preloaded guides.</p>		<p>R1066</p> 
<p>Open For long guides requiring shaft support and high rigidity.</p>		<p>R1067</p> 
<p>Open, adjustable For zero-clearance or preloaded guides.</p>		<p>R1068</p> 
<p>Side opening Load exerted on the direction of opening of open linear bushings results in a reduction in load rating. In order to prevent this and facilitate the installation of specific linear bushings, the linear sets with side opening were developed.</p>	<p>R1071</p> 	
<p>Side opening, adjustable For zero-clearance or preloaded guides.</p>	<p>R1072</p> 	
<p>Flanged This modular unit complements the linear set series and is used for designs with a vertical shaft.</p>		<p>R1081</p> 

Benefits, technical data, installation

Benefits

- Thanks to its material and wall thickness, precision housings offer extreme rigidity regardless of load direction, even under full load.
- The housings can be aligned with ease during assembly to prevent distortive stress on the linear bushing.
- This high precision guarantees the functional reliability of our linear bushings and allows these units to be fully interchangeable with each other.
- Since the housings are manufactured in large quantities, the user saves significant costs over in-house designs while maintaining quality.

Technical data

Operating temperatures

-10 °C to 80 °C. Higher temperatures allowed in size 12 and higher without wiper seals, see “Temperaturfaktor” on page 16.

Installation

Radial clearance

The radial clearance values shown in the table have been determined from statistics and correspond to values expected in practice.
The R1066, R1068 and R1072 linear sets come clamped to an h5 shaft (lower limit) and set to zero clearance.

Vertical dimension

The tolerance values for the vertical dimension “H” for the linear sets shown in the table have been determined from statistics and correspond to values expected in practice.



Bolts

We recommend bolts in accordance with ISO 4762-8.8 for fastening the linear sets.

Initial lubrication

Linear sets with standard linear bushings do not have an initial lubrication. Grease linear bushings before use, see “Initial lubrication” Section “Lubrication” on page 21.
Service life data is based on initial lubrication and relubricated linear bushings.

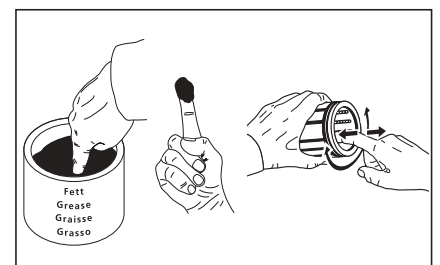

Linear sets with standard linear bushings

Linear sets, R1065 Closed

Linear sets, R1066 Adjustable

Design

- Precision housing (cast iron/steel)
- Standard linear bushing with wiper seals
- Two retaining rings



Shaft Ø d (mm)	Material number With two wiper seals LSG-M- ... -DD	Weight (kg)
8	R1065 208 00	0.09
12	R1065 212 00	0.16
16	R1065 216 00	0.27
20	R1065 220 00	0.45
25	R1065 225 00	0.89
30	R1065 230 00	1.33
40	R1065 240 00	2.51
50	R1065 250 00	3.68
60	R1065 260 00	6.73
80	R1065 280 00	15.32

R1065 1 ... 00 for higher temperatures (standard linear bushing without wiper seals)



Shaft Ø d (mm)	Material number With two wiper seals LSGE-M- ... -DD	Weight (kg)
8	R1066 208 00	0.09
12	R1066 212 00	0.16
16	R1066 216 00	0.27
20	R1066 220 00	0.45
25	R1066 225 00	0.89
30	R1066 230 00	1.33
40	R1066 240 00	2.51
50	R1066 250 00	3.68
60	R1066 260 00	6.73
80	R1066 280 00	15.32

The dynamic load ratings are based on a total travel of 100,000 m.
When based on 50,000 m, the C values in the table are multiplied by 1.26.

Explanation of sample short product name

LS	G	E	M	20	DD
Linear set	Cast iron	Adjustable	Standard linear bushing	Ø 20	With two seals

See page 96 for more information on short product names.

Dimensions

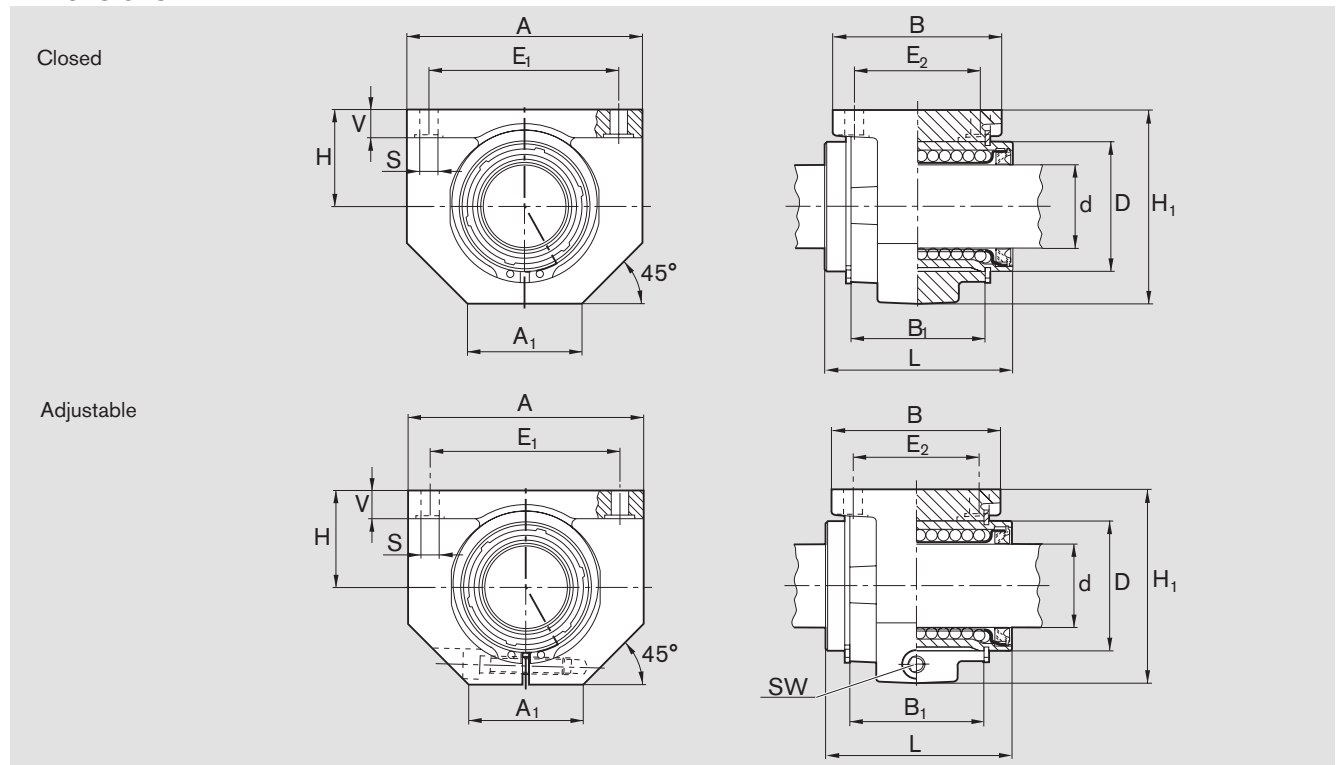

Dimensions (mm)														Radial clearance ²⁾ (μm)		Tolerance for dimension H ³⁾ (μm)		Load ratings ⁴⁾ (N)	
$\varnothing d$	D	H	H ₁ ¹⁾	L	A ¹⁾	A ₁ ¹⁾	B ¹⁾	B ₁	E ₁	E ₂	S	V ¹⁾	SW	R1065 h6 shaft	R1066	dyn. C	stat. C ₀		
8	16	15	28	25	32	16	28	14	25 ± 0.15	20 ± 0.15	3.4	5.0	2.0	+18 +5		320	240		
12	22	18	35	32	42	21	32	20	32 ± 0.15	23 ± 0.15	4.5	5.5	2.5	+20 +5		420	280		
16	26	22	42	36	50	26	35	22	40 ± 0.15	26 ± 0.15	4.5	6.5	3.0	+22 +5		580	440		
20	32	25	50	45	60	28	42	28	45 ± 0.15	32 ± 0.15	4.5	8.0	3.0	+23 +6		1,170	860		
25	40	30	60	58	74	38	54	40	60 ± 0.15	40 ± 0.15	5.5	9.0	5.0	+25 +6	Comes clamped to h5 shaft (lower limit) and set to zero tolerance	2,080	1,560		
30	47	35	70	68	84	41	60	48	68 ± 0.20	45 ± 0.20	6.6	10.0	5.0	+25 +6		+5 -19	2,820	2,230	
40	62	45	90	80	108	51	78	56	86 ± 0.20	58 ± 0.20	9.0	12.0	6.0	+30 +7		+4 -21	5,170	3,810	
50	75	50	105	100	130	57	70	72	108 ± 0.20	50 ± 0.20	9.0	14.0	8.0	+30 +7		+8 -25	8,260	6,470	
60	90	60	125	125	160	70	92	95	132 ± 0.25	65 ± 0.25	11.0	15.0	10.0	+33 +7		+8 -26	11,500	9,160	
80	120	80	170	165	200	85	122	125	170 ± 0.50	90 ± 0.50	13.5	22.0	14.0	+37 +8		+7 -28	21,000	16,300	

1) ISO 8062-3 - DCTG 9 tolerance.

2) Determined from working bore diameter and shaft tolerance statistics. When factoring in the outer diameter of the linear bushings and the housing bore, an h6 shaft produces similar radial clearance values as specified in the "H6H7" column under "Radial clearance" for the R0610 standard linear bushing.

3) Clamped (fastened) in relation to $\varnothing d$.

4) The load ratings indicated are minimal values as the orientation and direction of load cannot always be clearly defined.



Linear sets with standard linear bushings

Linear sets, R1067 Open

Linear sets, R1068 Open, adjustable

Design

- Precision housing (cast iron/steel)
- Secured with locating screw
- Standard linear bushing with wiper seals



Shaft Ø d (mm)	Material number With two wiper seals LSGO-M- ... -DD	Weight (kg)
20	R1067 220 00	0.39
25	R1067 225 00	0.74
30	R1067 230 00	1.14
40	R1067 240 00	2.25
50	R1067 250 00	3.13
60	R1067 260 00	5.78
80	R1067 280 00	13.15

R1067 1.. 00 for higher temperatures (standard linear bushing without wiper seals)



Shaft Ø d (mm)	Material number With two wiper seals LSGOE-M- ... -DD	Weight (kg)
20	R1068 220 00	0.38
25	R1068 225 00	0.74
30	R1068 230 00	1.12
40	R1068 240 00	2.20
50	R1068 250 00	3.11
60	R1068 260 00	5.72
80	R1068 280 00	13.09

Explanation of sample short product name

LS	G	O	M	20	DD
Linear set	Cast iron	Open	Standard linear bushing	Ø 20	With two seals

See page 96 for more information on short product names.

Dimensions

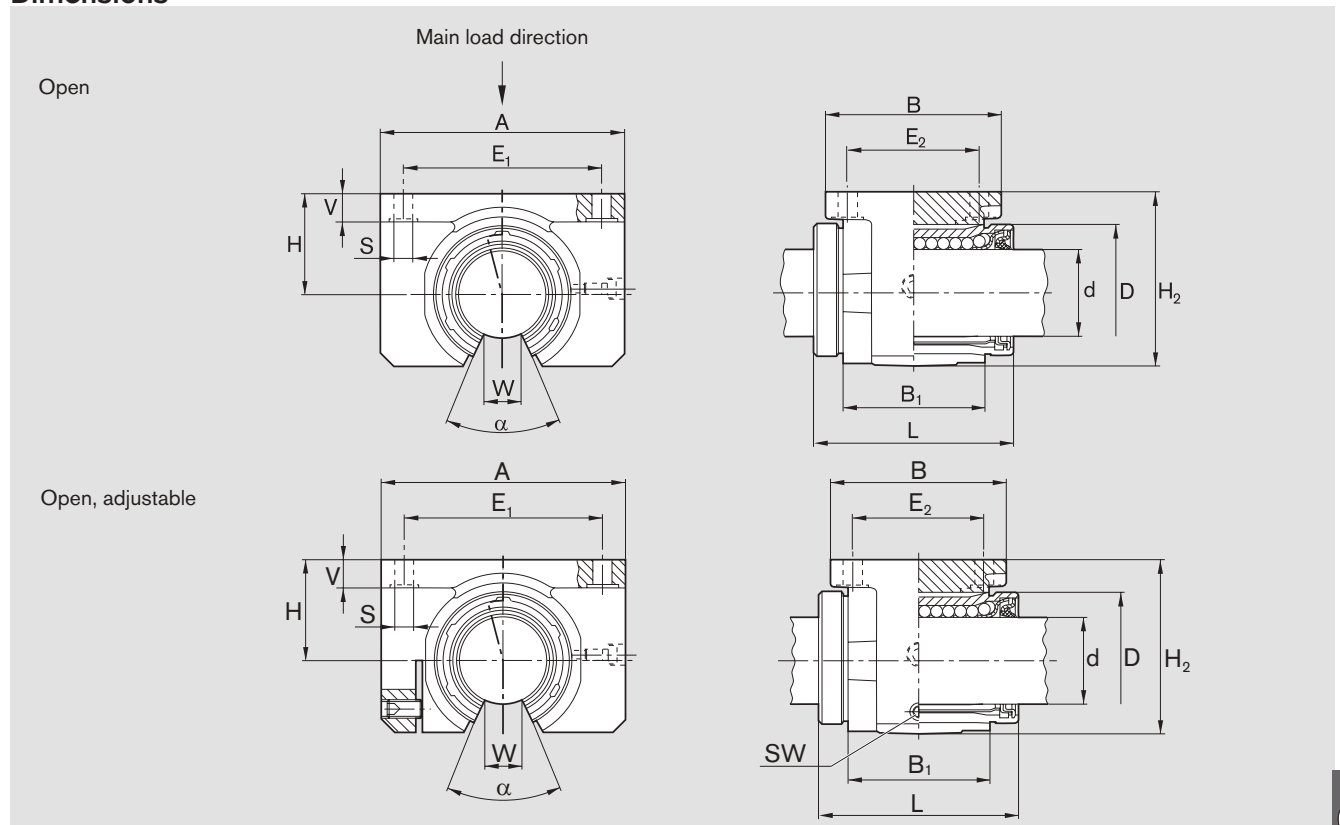

Dimensions (mm)															Angle α (°)	Radial clearance (μm)		Tolerance for dimension H^3 (μm)	Load ratings ⁴⁾ (N)	
$\varnothing d$	D	H	$H_2^{1)}$	L	$A^1)$	$B^1)$	B_1	E_1	E_2	S	$V^1)$	$W^2)$	SW	R1067 h6 shaft		R1068	dyn. C		stat. C_0	
20	32	25	42	45	60	42	28	45 ± 0.15	32 ± 0.15	4.5	8	10	2.5	60	+36 +4	Comes clamped to h5 shaft (lower limit) and set to zero clearance	+5 -19	1,280	970	
25	40	30	51	58	74	54	40	60 ± 0.15	40 ± 0.15	5.5	9	12.5	3	60	+38 +4		+5 -19	2,270	1,750	
30	47	35	60	68	84	60	48	68 ± 0.20	45 ± 0.20	6.6	10	12.5	3	50	+38 +4		+5 -19	2,890	2,390	
40	62	45	77	80	108	78	56	86 ± 0.20	58 ± 0.20	9.0	12	16.8	4	50	+45 +5		+4 -21	5,280	4,000	
50	75	50	88	100	130	70	72	108 ± 0.20	50 ± 0.20	9.0	14	21.0	5	50	+45 +5		+8 -25	8,470	6,900	
60	90	60	105	125	160	92	95	132 ± 0.25	65 ± 0.25	11.0	15	27.2	6	54	+50 +5		+8 -26	11,800	9,780	
80	120	80	140	165	200	122	125	170 ± 0.50	90 ± 0.25	13.5	22	36.3	8	54	+54 +6		+7 -28	21,500	17,400	

- 1) ISO 8062-3 - DCTG 9 tolerance.
- 2) Minimum size in relation to $\varnothing d$.
- 3) Clamped (fastened) in relation to $\varnothing d$.
- 4) The load ratings apply for the main load direction.

The dynamic load ratings are based on a total travel of 100,000 m.
When based on 50,000 m, the C values in the table are multiplied by 1.26.

⚠ Refer to the diagrams on page 99 for load in the direction of opening.



Linear sets with standard linear bushings

Linear sets, R1071 Side opening

Linear sets, R1072 Side opening, adjustable

Design

- Lightweight precision housing (aluminum)
- Secured by grooved taper pin
- Standard linear bushing
- Top wiper seals
- No lube port

Load exerted on the direction of opening of open linear bushings results in a considerable reduction in load rating. In order to prevent this and facilitate the installation of specific open linear bushings, the linear set with side opening was developed.



Shaft Ø d (mm)	Material number With two wiper seals LSAS-M- ... -DD	Weight (kg)
20	R1071 220 00	0.45
25	R1071 225 00	0.85
30	R1071 230 00	1.30
40	R1071 240 00	2.30
50	R1071 250 00	3.70



Shaft Ø d (mm)	Material number With two wiper seals LSASE-M- ... -DD	Weight (kg)
20	R1072 220 00	0.45
25	R1072 225 00	0.85
30	R1072 230 00	1.30
40	R1072 240 00	2.30
50	R1072 250 00	3.70

Explanation of sample short product name

LS	A	S	M	20	DD
Linear set	Aluminum	Side opening	Standard linear bushing	Ø 20	With two seals

See page 96 for more information on short product names.

Dimensions

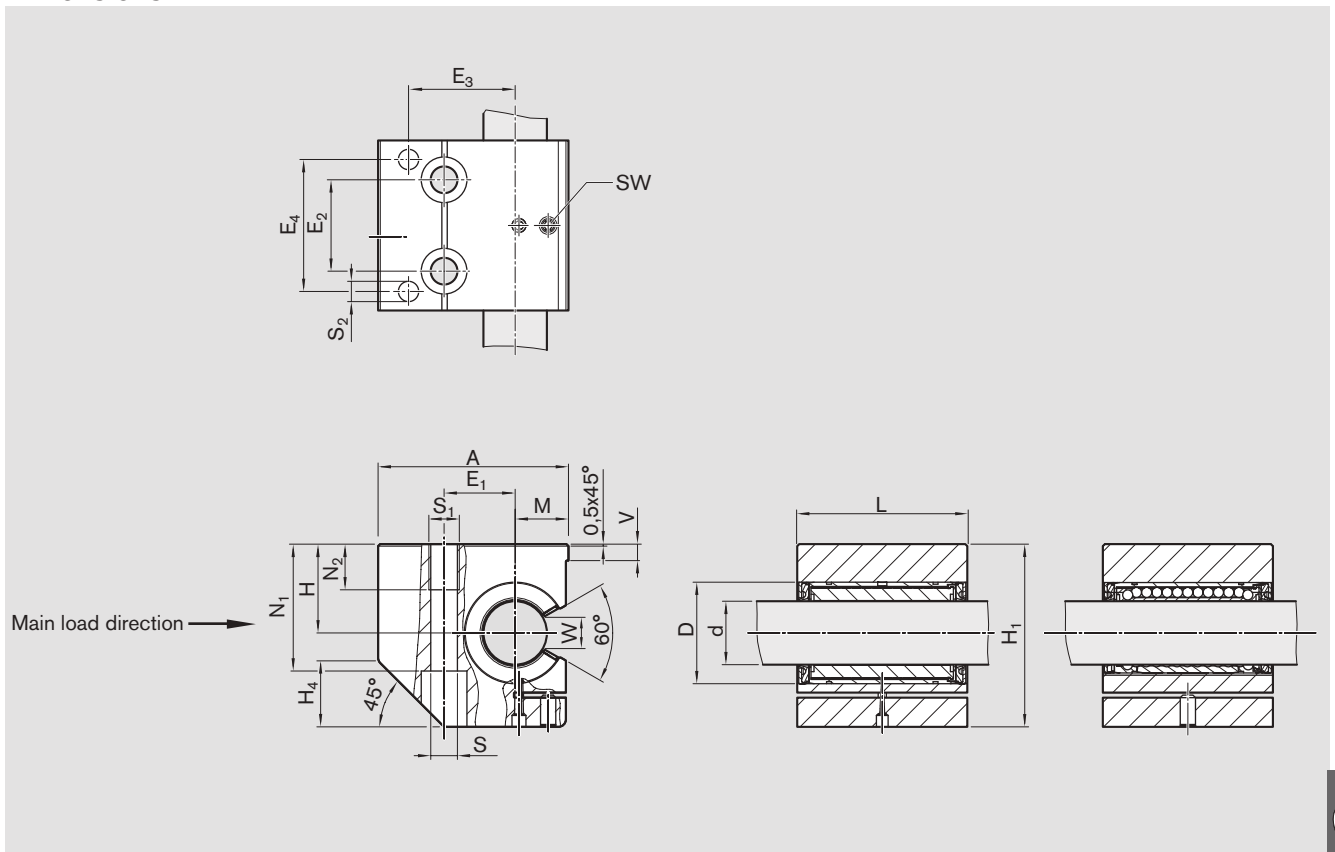

Dimensions (mm)

Ø d	D	A	E ₁ ±0.15	E ₂ ±0.15	E ₃	E ₄	H ¹⁾	H ₁	H ₄	L	M ¹⁾ ±0.01	N ₁	N ₂	S ²⁾	S ₁	S ₂ ²⁾	SW	V	W ⁴⁾	Radial clearance ⁵⁾ (µm)		Load ratings ⁶⁾ (N)	
																				R1071 h6 shaft	R1072	dyn. C	stat. C ₀
20	32	60	22	30	33	42	30 ^{+0.005 -0.019}	60	22	54	17	42	15	8.4	M10	6	2.5	5.0	10.0	+36 +4	Comes clamped to h5 shaft (lower limit) and set to zero clearance	1,280	970
25	40	75	28	36	42	52	35 ^{+0.005 -0.019}	72	26	67	21	50	18	10.5	M12	8	3.0	6.5	12.5	+38 +4		2,270	1,750
30	47	86	34	42	48	60	40 ^{+0.005 -0.019}	82	30	79	25	55	24	13.5	M16	10	3.0	8.0	12.5	+38 +4		2,890	2,390
40	62	110	43	48	62	68	45 ^{+0.004 -0.021}	100	38	91	32	67	30	15.5	M20	12	4.0	10.0	16.8	+45 +5		5,280	4,000
50	75	127	50	62	70	85	50 ^{+0.004 -0.021}	115	45	113	38	78	30	17.5	M20	12	5.0	12.0	21.0	+45 +5		8,470	6,900

- 1) Clamped (fastened), in relation to Ø d.
- 2) ISO 4762-8.8 socket head cap bolts.
- 3) Pin centering.
- 4) Minimum size in relation to Ø d.
- 5) Clamped (fastened).
- 6) The load ratings apply for the main load direction.

The dynamic load ratings are based on a total travel of 100,000 m.
When based on 50,000 m, the C values in the table are multiplied by 1.26.

See the notes on installing linear sets with side opening.

Refer to the diagrams on page 99 for load in the direction of opening.

Linear sets with standard linear bushings

Linear sets, R1081 Flanged

Design

- Flanged housing (lamellar graphite cast iron)
- Two retaining rings with additional two spacer rings (steel) for shaft diameters 12 to 40
- Standard linear bushing with wiper seals
- Radial clearance not adjustable



Shaft Ø d (mm)	Material number With two wiper seals LSGF-M- ... -DD	Weight (kg)
12	R1081 212 00	0.11
16	R1081 216 00	0.18
20	R1081 220 00	0.33
25	R1081 225 00	0.63
30	R1081 230 00	1.00
40	R1081 240 00	1.90
50	R1081 250 00	4.00
60	R1081 260 00	7.40
80	R1081 280 00	14.70

R1081 1.. 00 for higher temperatures (standard linear bushing without wiper seals)

Explanation of sample short product name

LS	G	F	M	20	DD
Linear set	Cast iron	Flanged	Standard linear bushing	Ø 20	With two seals

See page 96 for more information on short product names.

Dimensions

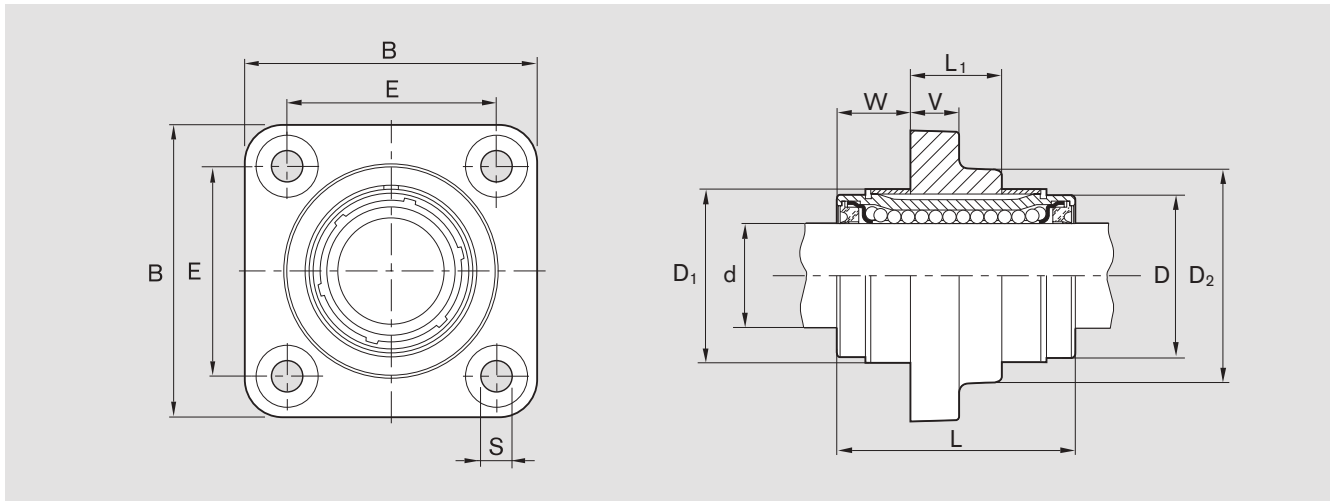

Dimensions (mm)											Radial clearance ²⁾		Load ratings ³⁾ (N)	
Ø d	B ¹⁾	L	L ₁	D	D ₁ +0.8	D ₂ ¹⁾	E	S H13	V ¹⁾	M	h6 shaft	(µm)	dyn. C	stat. C ₀
12	42	32	12	22	24	28	30±0.12	5.5	6	10		+20 +5	420	280
16	50	36	15	26	28.5	34	35±0.12	5.5	8	10.5		+22 +5	580	440
20	60	45	18	32	35	42	42±0.15	6.6	10	13.5		+23 +6	1,170	860
25	74	58	23	40	43	54	54±0.15	6.6	12	17.5		+25 +6	2,080	1,560
30	84	68	26	47	49.5	62	60±0.25	9.0	14	21		+25 +6	2,820	2,230
40	108	80	36	62	66.5	80	78±0.25	11	16	22		+30 +7	5,170	3,810
50	130	100	72	75	81	98	98±0.25	11	18	14		+30 +7	8,260	6,470
60	160	125	95	90	96	115	120±0.50	14	22	15		+33 +7	11,500	9,160
80	200	165	125	120	129	150	155±0.50	14	26	20		+37 +8	21,000	16,300

1) ISO 8062-3 - DCTG 9 dimensional tolerance.

2) Determined from working bore diameter and shaft tolerance statistics. When factoring in the outer diameter of the linear bushings and the housing bore, an h6 shaft produces similar radial clearance values as specified in the "H6H7" column under "Radial clearance" for the R0610 standard linear bushing.

3) The load ratings indicated are minimal values as the orientation and direction of load cannot always be clearly defined.

The dynamic load ratings are based on a total travel of 100,000 m.

When based on 50,000 m, the C values in the table are multiplied by 1.26.



Segmental linear bushings

Product overview

The benefits

- Lightweight, stable and low-cost linear set with reinforced plastic housing
- Designed especially for general requirements
- Also available in stainless steel for medical, chemistry and food industries
- Separate wiper seals optional

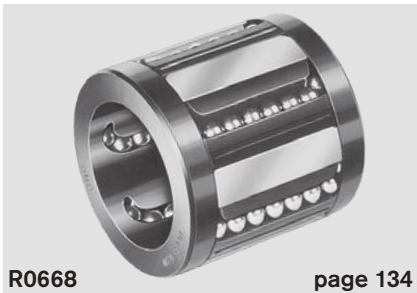

R0668 page 134

Segmental linear bushing

Explanation of short product name

Sample linear bushing:

Segmental linear bushing
KBSE-20-NR

Definition of codes		KB	SE	20	NR	
Type	Linear bushing = KB					NR = Stainless steel
Series	Segmental = SE					
Form	Closed =				NR = No seals	Linear bushing version
Shaft diameter	= 20					

Segmental linear bushings

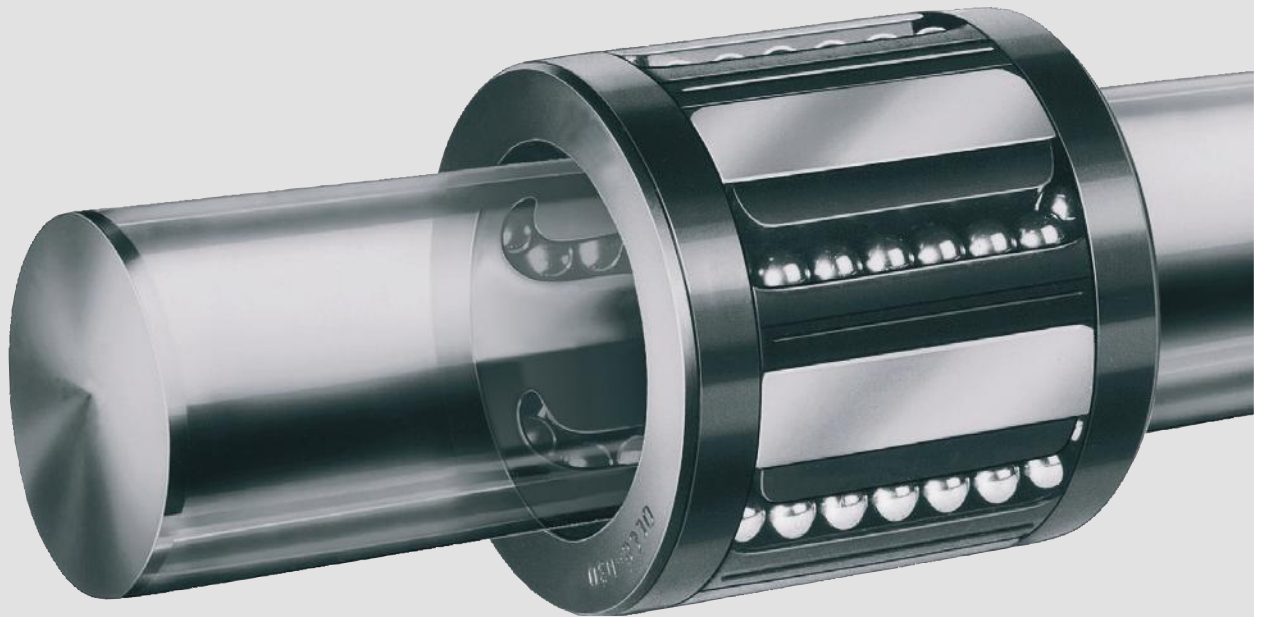

R1060

page 136

Adjustable



Sample linear set:

Linear set with segmental linear bushing
LSK-20-DD-NR

Definition of codes		LS	K	20	DD	NR
Type	Linear set	=	LS			
Material (housing) (linear set only)	Plastic (with segmental linear bushing)	=	K			
Form	Closed	=				
Shaft diameter		=		20		
Seals	With two seals	=			DD	
Linear bushing version	Stainless steel	=				NR
	Normal	=				

Segmental linear bushings

Technical data

Please observe general technical principles and follow the lubricating and installation instructions.

Friction

The friction coefficients μ of the unsealed segmental linear bushings are 0.001–0.004 when lubricated with oil. The friction coefficient is lowest under heavy load, but can still be above the specified value even under low load.

The table shows the friction generated by linear bushings with seals on both ends when not under radial load. They depend on speed and lubrication.

Shaft \varnothing d (mm)	Breakaway force Reference value (N)	Friction Reference value (N)
12	3.0	1.5
16	4.5	2.0
20	5.0	2.5
25	7.0	3.0
30	9.0	4.0
40	12.0	5.0

Speed

$$v_{\max} = 3 \text{ m/s}$$

Acceleration

$$a_{\max} = 150 \text{ m/s}^2$$

Operating temperature

-10 °C to 80 °C (normal version)

-10 °C to 65 °C (stainless steel version)

Effect of load direction on load rating

Depending on installation, the listed load ratings should be chosen at the minimum or maximum position and should be based on the calculations.

If the load direction is clearly defined and the segmental linear bushings can be installed at the maximum position, the load ratings C_{\max} (dynamic load rating) and $C_{0\max}$ (static load rating) can be used.

If directed installation is not possible or the load direction is not defined, the minimum load ratings must be used.

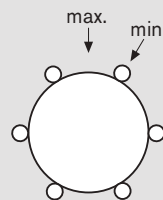

Initial lubrication

Segmental linear bushings do not have an initial lubrication. Grease linear bushings before use, see "Initial lubrication" Section "Lubrication" on page 21. Service life data is based on initial lubrication and relubricated linear bushings.

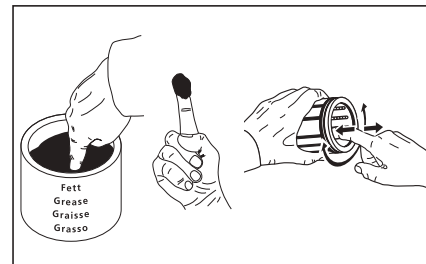

Installation, securing

Reduced load rating with short stroke

When short stroke is present, the service life of the shaft is less than that of the segmental linear bushing. The load ratings C in the tables must therefore be multiplied by the factor f_s .

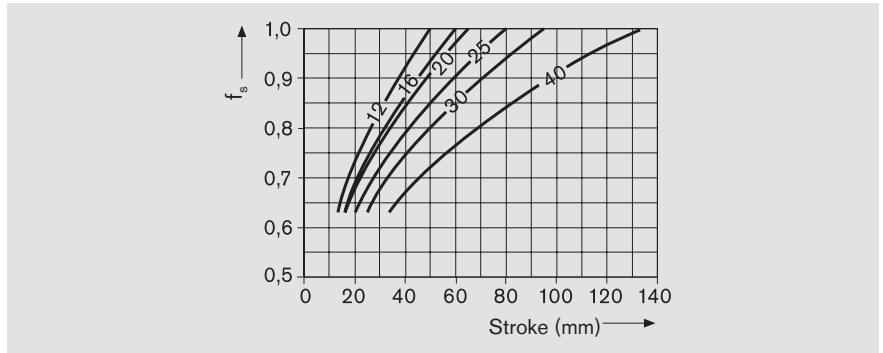

Operating under difficult conditions

For constantly humid or damp conditions caused, e.g., by water-based coolants/lubricants, we recommend the stainless steel linear bushing with parts made of steel in accordance with ISO 683-17/EN10088.

Installation

Install the segmental linear bushings using an arbor press (see Section Installation). In order to prevent contamination in the segmental linear bushing, we recommend making sure that a steel segment is covered by the slot when installing in slotted receivers.

Securing

Secured with wiper seal

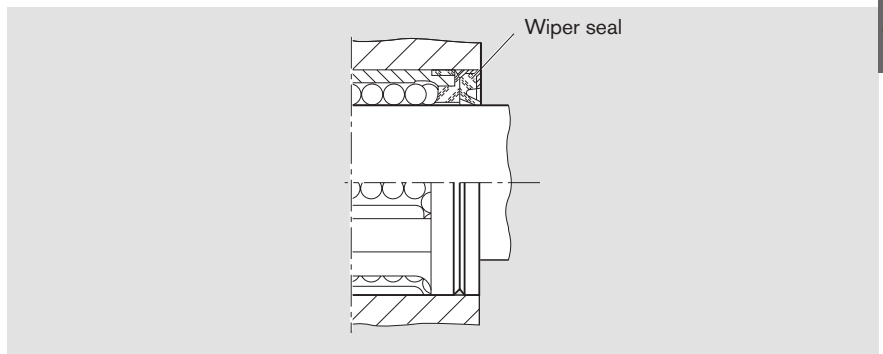

Secured with metal case

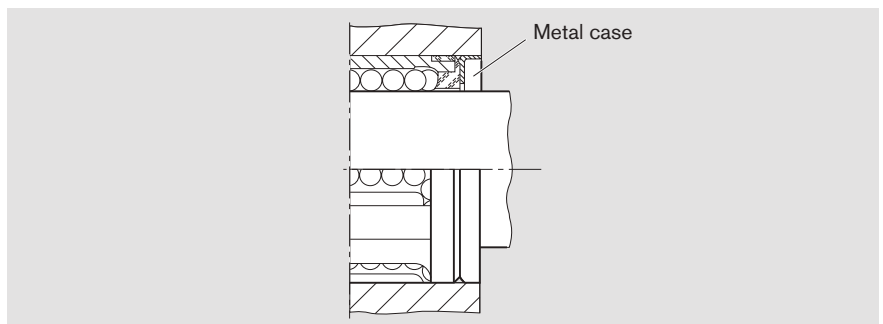

Segmental linear bushings

Segmental linear bushings,
R0668

Normal

Design

- Balls made of rolling bearing steel
- Hardened segmental steel plates
- Ball retainer and retaining rings made of PA 11

Stainless

Design

- Balls made of 1.3541 steel
- Segmental steel plates made of 1.4300 steel
- Ball retainer and retaining rings made of PA 11



Shaft Ø d (mm)	Material number		Weight (kg)
	Normal KBSE- ...	Stainless KBSE- ... -NR	
12	R0668 012 00	R0668 012 30	0.013
16	R0668 016 00	R0668 016 30	0.020
20	R0668 020 00	R0668 020 30	0.031
25	R0668 025 00	R0668 025 30	0.057
30	R0668 030 00	R0668 030 30	0.096
40	R0668 040 00	R0668 040 30	0.170

Wiper seal



Shaft Ø d (mm)	Material number		Weight (g)
	Wiper seal for normal version ¹⁾	Wiper seal for stainless steel version ¹⁾	
12	R1331 512 00	R1331 512 30	1.1
16	R1331 516 00	R1331 516 30	2.1
20	R1331 520 00	R1331 520 30	3.5
25	R1331 525 00	R1331 525 30	4.9
30	R1331 530 00	R1331 530 30	7.1
40	R1331 540 00	R1331 540 30	10.6

Metal case

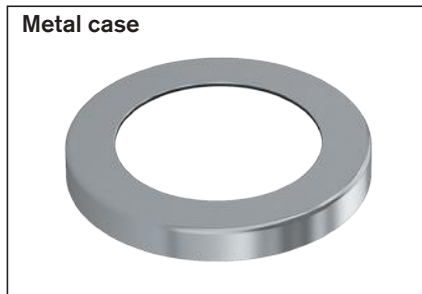

Ø d (mm)	Material number		Weight (g)
	Metal case for normal version ¹⁾	Metal case for stainless steel version ¹⁾	
12	R0901 043 00	R0901 043 30	0.6
16	R0901 044 00	R0901 044 30	1.6
20	R0901 045 00	R0901 045 30	2.5
25	R0901 046 00	R0901 046 30	3.4
30	R0901 047 00	R0901 047 30	4.4
40	R0901 048 00	R0901 048 30	6.7

1) For axial securing.

Explanation of sample short product name

KB	SE		12	NR
Linear bushing	Segmental	Closed	Ø 12	Stainless steel

See page 130 for more information on short product names.

Dimensions

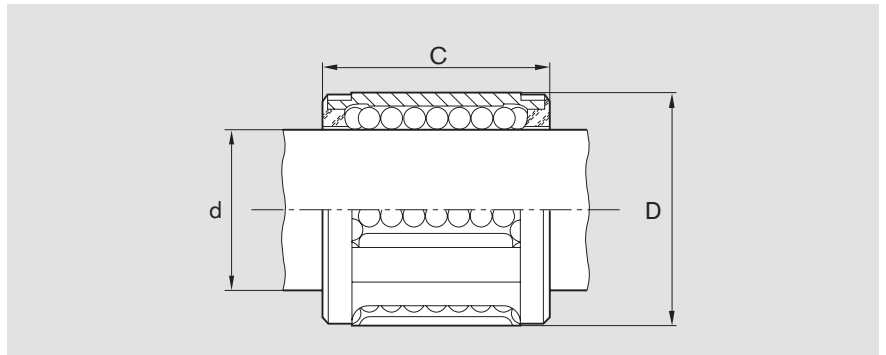

Dimensions (mm)			Rows of balls	Radial clearance (µm)		Load ratings (N)				Stainless			
Ø d	D	C js14		Shaft/bore		Normal		Stainless		Stainless		Stainless	
				h6/H7	h6/K7	min.	dyn. C max.	min.	stat. C ₀ max.	min.	dyn. C max.	min.	stat. C ₀ max.
12	20	24	5	+32 0	+17 -15	480	570	420	620	240	290	330	490
16	25	28	5	+32 0	+17 -15	720	860	620	910	360	430	490	730
20	30	30	6	+33 -1	+18 -16	1,020	1,080	870	1,120	510	540	690	890
25	37	37	6	+36 0	+18 -18	1,630	1,730	1,360	1,750	820	870	1,090	1,400
30	44	44	6	+36 0	+18 -18	2,390	2,530	1,960	2,510	1,200	1,270	1,570	2,000
40	56	56	6	+42 -1	+21 -22	3,870	4,100	3,270	4,180	1,940	2,050	2,610	3,340

The dynamic load ratings are based on a total travel of 100,000 m.
When based on 50,000 m, the C values in the table are multiplied by 1.26.



Wiper seal

Design:

- Metal case
- Elastomer wiper seal

Metal case

Material:

- Normal (galvanized)
- or stainless steel (1.4301).

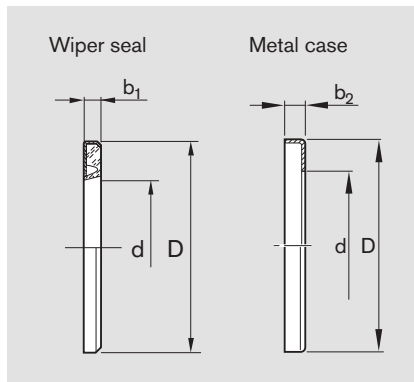

Dimensions (mm)			
Ø d	D ¹⁾	b ₁	b ₂
12	20	+0.3 3	+0.5 3
16	25	3	3
20	30	4	4
25	37	4	4
30	44	5	5
40	56	5	5

- 1) Outer diameter D is oversized by about 0.1 mm.
No additional securing is needed.

Linear sets with segmental linear bushings

Linear sets, R1060 Adjustable Normal or stainless

Design

- Pedestal bearing housing made of reinforced PA
- Lightweight, stable and affordable
- Segmental linear bushing
- Also available in stainless steel under KBSE-NR
- Two interchangeable wiper seals
- Radial clearance adjustable



Shaft Ø d (mm)	Material number		Weight (kg)
	Normal LSK-...-DD	Stainless ¹⁾ LSK-...-DD-NR	
12	R1060 212 00	R1060 212 20	0.041
16	R1060 216 00	R1060 216 20	0.063
20	R1060 220 00	R1060 220 20	0.077
25	R1060 225 00	R1060 225 20	0.158
30	R1060 230 00	R1060 230 20	0.277
40	R1060 240 00	R1060 240 20	0.470

1) A2 stainless steel bolt, washer and nut

Explanation of sample short product name

LS		K		12	DD	NR
Linear set	Plastic (with segmental linear bushing)	Closed		Ø 12	With two seals	Stainless steel

See page 131 for more information on short product names.

Dimensions

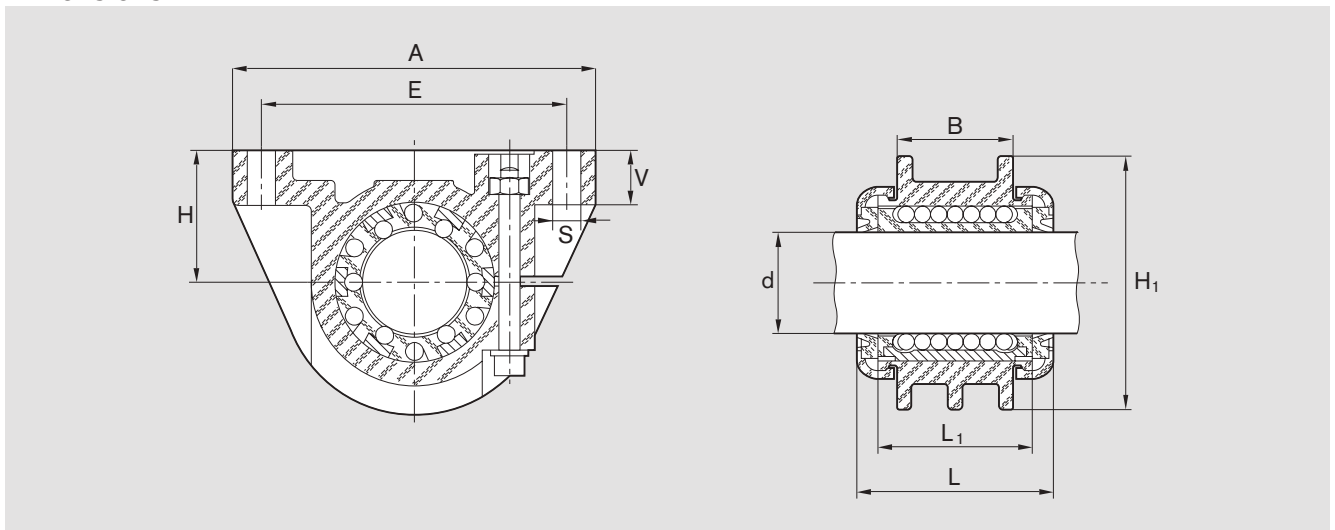

Dimensions (mm)										Radial clearance (µm)	Load ratings ²⁾ (N)			
Ø d	H ¹⁾	H ₁	L	L ₁	A	B	E	S	V		Normal dyn. C	Normal stat. C ₀	Stainless dyn. C	Stainless stat. C ₀
12	18 ^{±0.05}	35	31	24	55	20	43 ^{±0.15}	4.4	8.0	Comes clamped to h5 shaft (lower limit) and set to zero clearance	480	420	240	330
16	22 ^{±0.05}	42	35	28	66	22	53 ^{±0.20}	5.5	9.5		720	620	360	490
20	25 ^{±0.08}	50	38	30	69	23	58 ^{±0.25}	5.5	10.5		1,020	870	510	690
25	30 ^{±0.08}	60	46	37	87	30	72 ^{±0.25}	6.6	11.5		1,630	1,360	820	1,090
30	35 ^{±0.10}	70	55	44	97	36	80 ^{±0.30}	6.6	13.0		2,390	1,960	1,200	1,570
40	45 ^{±0.10}	90	67	56	124	48	103 ^{±0.30}	8.6	17.0		3,870	3,270	1,940	2,610

- 1) In relation to nominal shaft dimension d.
- 2) The load ratings indicated are minimal values as the orientation and direction of load cannot always be clearly defined.

The dynamic load ratings are based on a total travel of 100,000 m.
 When based on 50,000 m, the C values in the table are multiplied by 1.26.



Radial linear bushings

Product overview

The benefits

- High-precision linear bushing for moving very heavy loads
- Radial ball redirection allows numerous rows of balls and extremely high load ratings
- Very high rigidity
- Extra smooth running
- Fully sealed or without wiper seals
- **Heavy-duty guide with degrees of freedom in circumferential direction**
- For applications where other linear guides tend to warp due to imprecise substructures.
- Linear sets with steel housing
- Radial compact sets for highly compact designs



R0678 page 144

Radial linear bushing



R1613 page 154

Radial compact set, open, adjustable

Explanation of short product name

Sample linear bushing:

Radial linear bushing
KBR-30-VD

Radial compact set, open, adjustable
KB-RCS-E-30-VD

Definition of codes		KB	R	30	VD		
Type	Linear bushing	= KB				VD = Fully sealed	Seals
Series	Radial	= R				DD = With two seals	
	Compact set	= CS				= No seals	
	Adjustable	= E					
Shaft diameter		= 30					

Radial linear bushings



R1076 page 146
Linear set, open, adjustable

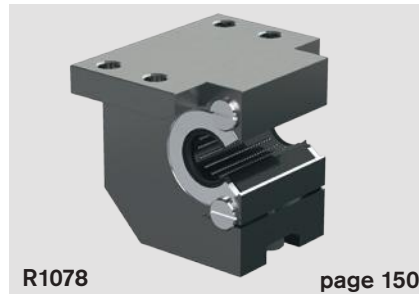

R1078 page 150
Linear set, side opening, adjustable

Sample linear set:

Linear set with radial linear bushing (side opening, adjustable)
LSRSE-30-DD

Definition of codes		LS	R	E	30	DD
Type	Linear set	= LS				
Series	Radial, open	= R				
	Radial, side opening	= S				
Housing	Adjustable	= E				
Shaft diameter		= 30				
Seal	Two seals	= DD				



Radial linear bushings

Technical data

Please observe general technical principles and follow the installation instructions at the beginning of this catalog as well as the following additional technical specifications.

Seal Radial linear bushings come either
 – fully sealed with integrated wiper seals and linear seal, or
 – with separate wiper seals

Friction The friction coefficients μ of unsealed radial linear bushings are 0.001 – 0.002 when lubricated with oil.
 Radial linear bushings either fully sealed or with separate wiper seals produce the following friction coefficients:

Shaft $\varnothing d$ (mm)	Separate wiper seals		Fully sealed	
	Breakaway force Reference value (N)	Friction Reference value (N)	Breakaway force Reference value (N)	Friction Reference value (N)
30	24	8	24	12
40	32	11	32	16
50	40	14	40	20
60	48	16	48	24
80	60	20	60	30

Speed $v_{max} = 2 \text{ m/s}$

Acceleration $a_{max} = 50 \text{ m/s}^2$

Operating temperature -20 °C to 100 °C
 Separate wiper seals: -20 °C to 80 °C, 100 °C temporarily

Rigidity Combine a radial linear bushing with a continuously supported guide shaft for a precise, rigid design.
 The following figure shows load-dependent spring. The diagram applies for installation:
 – Without preload
 – With zero clearance (no preload)
 – For load direction $\rho = 0^\circ$ to 90° and 270° to 360°

Radial linear bushing rigidity

Installing with preload reduces spring. Additional spring in all parts of a linear guide (housing, shaft, shaft support rail) depends on the load direction. Reference values for total spring with R1076 and R1010 elements: load direction factor multiplied by spring δ (from right diagram).

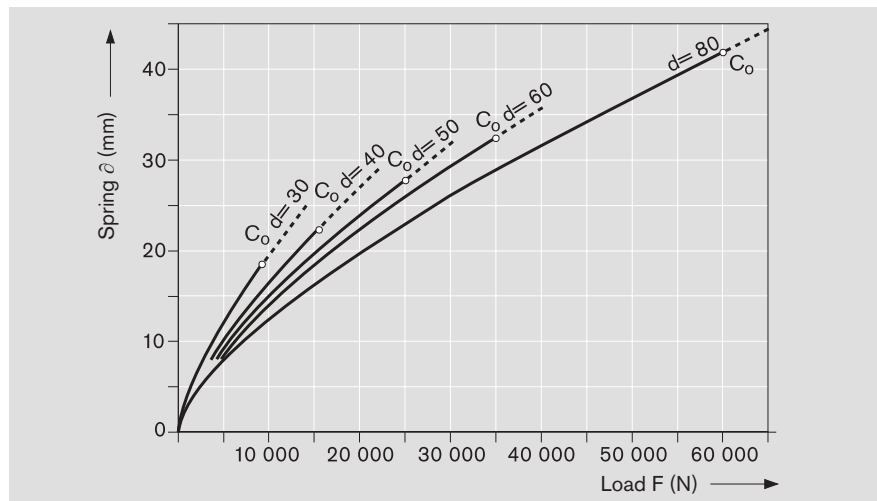

Load direction ρ	0°	90°	180°	270°
Total spring	1 x δ	1.8 x δ	3.5 x δ	1.8 x δ

Effect of load direction on load rating

The load ratings C and C_0 specified for radial linear bushings apply for load direction $\varrho = 0^\circ$. If the external load is at an angle $\varrho = 90^\circ$ to 270° , a reduced load rating must be factored in.

The load rating is then determined by multiplying the indicated load rating C or C_0 by the load direction factors f_ϱ or $f_{\varrho 0}$. This reduced load rating can be avoided by careful installation of the radial linear bushings.

Load direction factors

Radial linear bushings, R0678

Linear sets, R1076 Open, adjustable

Radial compact sets, R1613 Open, adjustable

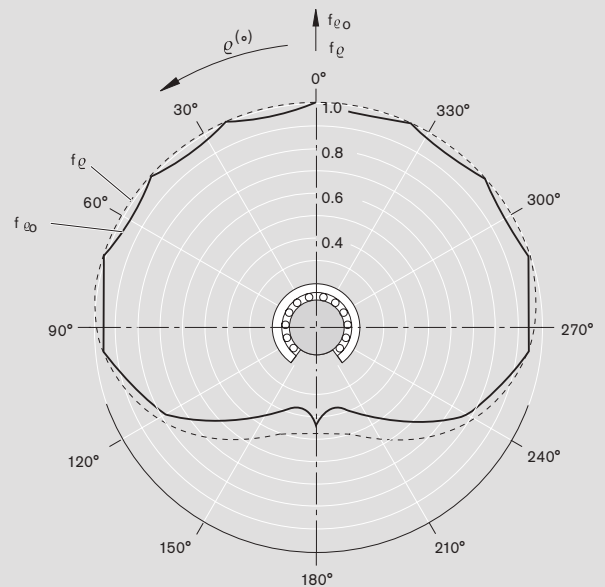

Linear sets, R1078 Side opening, adjustable

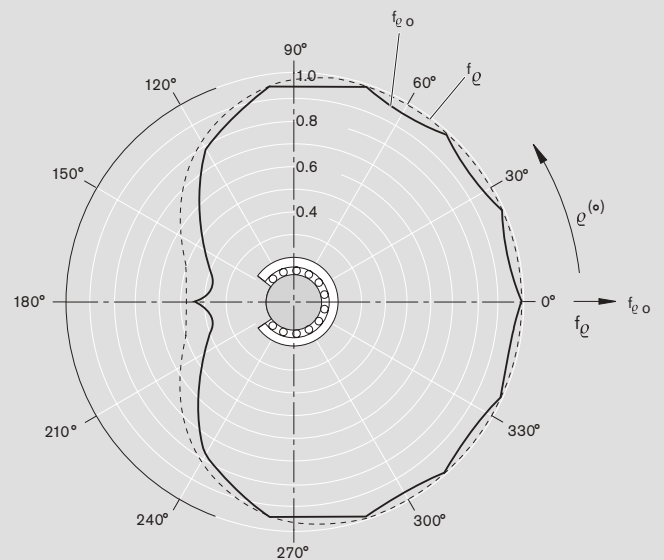

Radial linear bushings

Installation, securing

Notes on installation, securing

The shaft must be continuously supported to avoid deflection. See Section “Steel shafts with ready-mounted shaft support rails for radial linear bushings”.

The radial linear bushing is pressed into the housing as shown in the installation instructions.

Additional securing is required when vibrations or higher acceleration are present, specifically when installed vertically.

During installation, make sure the shafts are first fastened to the shaft support rails, then align the housing with the radial linear bushings to the shafts and then fasten it to the table.

Recommended installation tolerances

See the dimension table for radial linear bushings for bore tolerances. The housing is available with a slot and adjusting screw on one side in order to set the housing to zero clearance or a specific preload. Radial linear bushings are also available as complete linear sets with housing. See “General technical principles and installation instructions” at the beginning of this catalog for parallelism offsets.

Initial lubrication

Radial linear bushings do not have an initial lubrication. Grease linear bushings before use, see “Initial lubrication” Section “Lubrication” on page 21.

Service life data is based on initial lubrication and relubricated linear bushings.

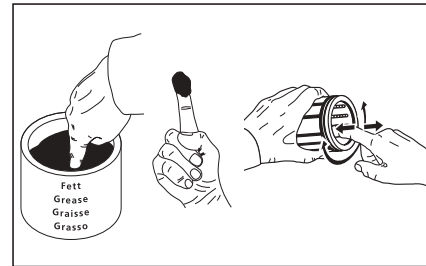

Note on lubrication

On-shaft lubrication only via lubricating hole until lubricant comes out.

Installation instructions for radial linear bushings

To avoid damage during installation, only press the radial linear bushing into the housing bore using a press or puller. Follow the figures and instructions below during installation. Before installation, make sure there is no oil on the outer sheath of the radial linear bushing or in the housing bore.

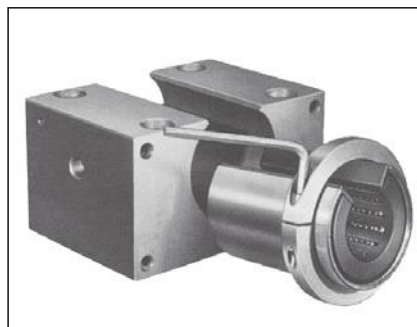

Place the mounting ring¹⁾ on as shown in the figure and use the adjusting screw to compress the radial linear bushing until it can be easily inserted into the housing bore by hand. The mounting ring hole must be about 0.5 mm larger than the outer diameter D of the radial linear bushing.

1) Mounting ring material number: R0940 0...00

Shaft diameter d

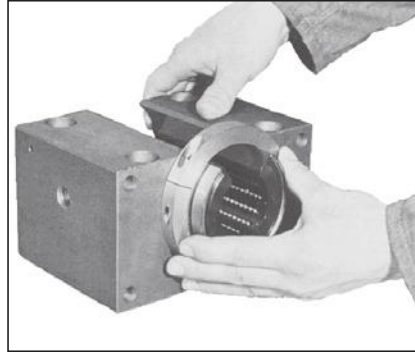

Once inserted, align the opening in the radial linear bushing with the opening in the housing and remove the mounting ring.

Press the preassembled radial linear bushing into the housing with a press.

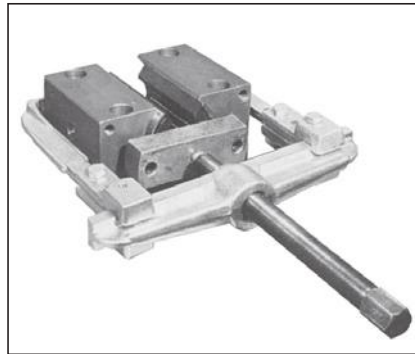

The preassembled radial linear bushing can also be pressed in with a puller. The pressure fitting must be on the ball bearings in the push rod (arrow). If this is not the case, an axial bearing must be placed on top of the push rod in order to prevent the torque that occurs from rotating the radial linear bushing in the housing.

Notes

- If the radial linear bushing and housing openings are not aligned when installed:
 - Push out the radial linear bushing (press or puller)
 - Set the mounting ring on
 - Correct the position of the opening
 - Install as shown in the figures
- The ends of the shaft must be chamfered.
- Make sure the radial linear bearing is not skewed when pressing it onto the shaft.
- The radial linear bushing may not rotate on the shaft.
- Top wiper seals must be aligned with the radial linear bushing during installation and pressed on with a press or puller.



Radial linear bushings

Radial linear bushings, R0678

No wiper seal or fully sealed

Design

- Hardened and machined steel sleeve
- Ball retainer made of reinforced PA
- Balls made of rolling bearing steel
- Two retaining rings
- No wiper seal
- Fully sealed
- Separate wiper seals
- Relubricatable



Shaft Ø d (mm)	Material number		Weight (kg)
	No wiper seal KBR-...	Fully sealed KBR-...-VD	
30	R0678 030 00	R0678 230 45	0.7
40	R0678 040 00	R0678 240 45	1.4
50	R0678 050 00	R0678 250 45	2.5
60	R0678 060 00	R0678 260 45	4.9
80	R0678 080 00	R0678 280 45	10.4

Wiper seals



Shaft Ø d (mm)	Material number		Weight (kg)
	Wiper seals		
30	R1331 930 00 ¹⁾		0.050
40	R1331 940 00 ¹⁾		0.075
50	R1331 950 00 ¹⁾		0.145
60	R1331 960 00 ¹⁾		0.230
80	R1331 980 00 ¹⁾		0.400

1) Please inquire about delivery time

Explanation of sample short product name

KB	R	30	VD
Linear bushing	Radial	Ø 30	Fully sealed

See page 138 for more information on short product names.

Dimensions

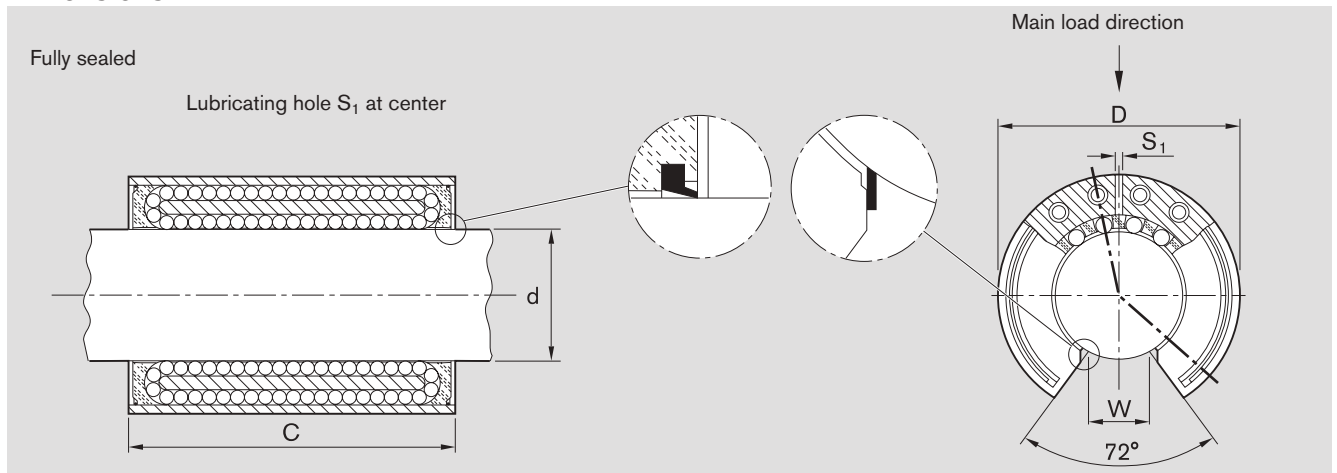

Dimensions (mm)				S1	Rows of balls	Radial clearance (µm)			Load ratings ³⁾ (N)	
Ø d	D	C h11	W ¹⁾			h6/H6	h6/JS6 ²⁾	h6/K6 ²⁾	dyn. C	stat. C ₀
30	60	75	14.0	3	12	+21 -10	+12 -20	+6 -25	8,500	9,520
40	75	100	19.5	3	12	+23 -13	+13 -22	+8 -28	13,900	16,000
50	90	125	24.5	3	12	+25 -12	+14 -23	+7 -30	20,800	24,400
60	110	150	29.0	4	12	+26 -15	+15 -26	+8 -33	29,500	34,100
80	145	200	39.0	4	12	+29 -15	+16 -27	+8 -36	54,800	61,500

1) Minimum size in relation to shaft diameter d.

2) Note reduction in service life due to high preload (see tables TB-06-052-05 und TB-06-052-06).

3) The load ratings apply for the main load direction $\rho = 0^\circ$.

The dynamic load ratings are based on a total travel of 100,000 m.

When based on 50,000 m, the C values in the table are multiplied by 1.26.

Wiper seals

Design

- Steel retaining ring
- Elastomer wiper seal

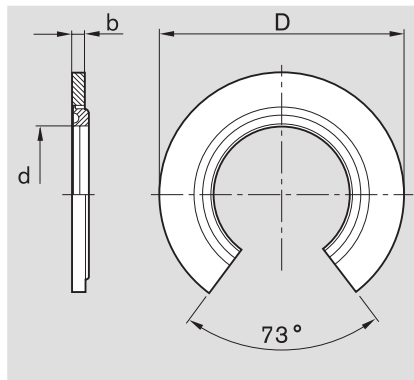

Dimensions (mm)		
Ø d	D ⁴⁾	b
30	60	5
40	75	5
50	90	7
60	110	7
80	145	7

4) Outer diameter D is oversized by about 0.1 mm. Additional securing is not required except where vibrations or high acceleration are present.



Linear sets with radial linear bushings

Linear sets, R1076 Open, adjustable

Design

- Precision housing (steel)
- Radial linear bushing
- Two wiper seals
- Relubricatable

When combined with precision steel shafts and shaft support rails, these linear sets can be used to create heavy-duty guides with extremely high rigidity.



Shaft Ø d (mm)	Material number with two wiper seals LSRE-...-DD	Weight (kg)
30	R1076 230 20 ¹⁾	6.1
40	R1076 240 20 ¹⁾	11.8
50	R1076 250 20 ¹⁾	19.7
60	R1076 260 20 ¹⁾	38.4
80	R1076 280 20 ¹⁾	76.1

1) Please inquire about delivery time

Explanation of sample short product name

LS	R	E	30	DD
Linear set	Radial, open	Adjustable	Ø 30	With two seals

See page 138 for more information on short product names.

Dimensions

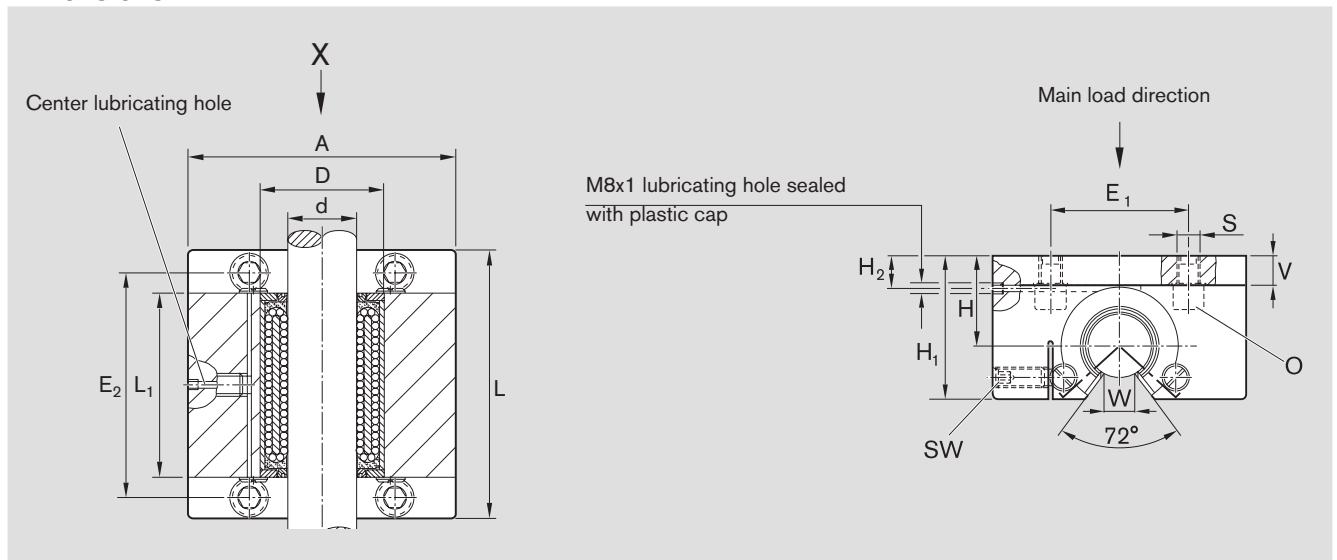

Dimensions (mm)															Radial clearance (µm)	Tolerance For dimension H ⁴⁾ (µm)	Load ratings ⁵⁾ (N)	
Ø d	D	A ¹⁾	L ¹⁾	L ₁ +0.5	H	H ₁ ¹⁾	H ₂	V ¹⁾	E ₁ ±0.5	E ₂ ±0.5	S H13	W ²⁾	O ³⁾	SW			dyn. C	stat. C ₀
30	60	140	130	84	48	75	18.0	16	75	108	11.0	14.0	M10x30	5	+15 -5	8,500	9,520	
40	75	170	160	109	60	94	22.5	20	90	135	13.5	19.5	M12x40	6	+17 -4	13,900	16,000	
50	90	200	200	138	70	110	25.0	23	110	170	17.5	24.5	M16x50	8	+18 -5	20,800	24,400	
60	110	240	240	163	85	135	30.0	28	130	200	22.0	29.0	M20x60	10	+23 -4	29,500	34,100	
80	145	310	310	213	110	175	37.5	35	170	260	26	39.0	M24x80	12	+22 -5	54,800	61,500	

- 1) Tolerance: js16.
- 2) Minimum size in relation to shaft diameter d.
- 3) ISO 4762-8.8 socket head cap bolts. Recommendation applies for bolting in steel or cast iron threads.
- 4) Clamped (fastened), in relation to nominal shaft dimension d.
- 5) The load ratings apply for the main load direction $\rho = 0^\circ$.

The dynamic load ratings are based on a total travel of 100,000 m.
When based on 50,000 m, the C values in the table are multiplied by 1.26.



Steel shafts with ready-mounted shaft support rails for radial linear bushings

R1018 steel shaft with ready-mounted shaft support rail

Material

– Shaft support rail: Steel

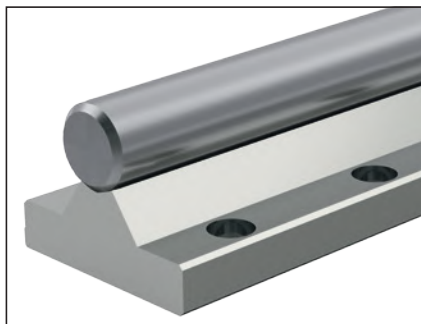

Shaft Ø d (mm)	Material number	Weight (kg/m)
30	R1018 030 .. ¹⁾	20.5
40	R1018 040 .. ¹⁾	31.0
50	R1018 050 .. ¹⁾	50.0
60	R1018 060 .. ¹⁾	70.0
80	R1018 080 .. ¹⁾	121.0

Shafts:

— 00 = h6 heat-treated steel

— 30 = h6 stainless steel

— 60 = h6 hard chrome-plated heat-treated steel

1) Please inquire about delivery time

Ordering example:

Shaft diameter 30 mm, h6, heat-treated steel, 1,200 mm long, ready-mounted shaft support rail R1052 1300 00 is ordered as:

R1018 030 00/1200 mm.

R1052 shaft support rails, length (mm) 600^{-0.5}_{-1.5}



Shaft Ø d (mm)	Material number	Weight (kg)
30	R1052 130 00 ¹⁾	9.0
40	R1052 140 00 ¹⁾	12.7
50	R1052 150 00 ¹⁾	20.7
60	R1052 160 00 ¹⁾	29.0
80	R1052 180 00 ¹⁾	48.9

1) Please inquire about delivery time

Dimensions

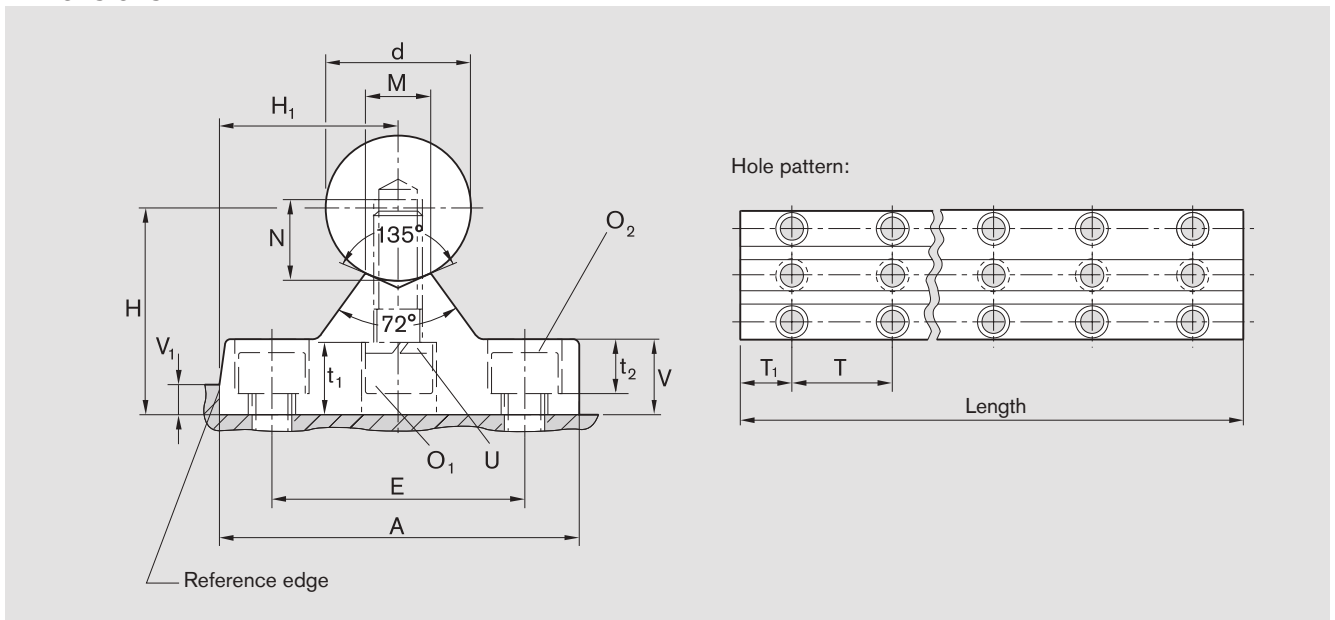

Dimensions (mm)														
Ø d	A	H ¹⁾ js7	H ₁ js7	V	V ₁ ²⁾	M -0.5	E	T	t ₁	t ₂	N	O ₁ ISO 4762-8.8	O ₂ ISO 4762-8.8	U DIN7980 ³⁾
30	80	50	40.0	19	7.0	13	55	60	22.0	13.5	17	M10x30	M10	10
40	100	60	50.0	22	8.5	18	70	75	22.0	16.0	21	M12x40	M12	12
50	125	75	62.5	30	9.0	23	90	100	28.0	21.0	28	M16x50	M16	16
60	150	90	75.0	34	13.0	27	110	120	34.0	25.5	32	M20x60	M20	20
80	200	115	100.0	42	18.0	37	140	150	38.5	30.5	40	M24x80	M24	24

- 1) Measured with gauging shaft, nominal dimension d and length about 50 mm.
- 2) Recommended design; no reference edge on opposite side (V₁) and align parallel over shafts.
- 3) DIN 7980 discontinued. Spring washer commercially available.



Linear sets with radial linear bushings

Linear sets, R1078 Side opening, adjustable

Design

- Precision housing with side opening (steel)
- Radial linear bushing
- Two wiper seals
- Relubricatable

Significant reduction in load rating must be factored in if open linear bushings are under load opposite the direction of opening.

This linear set allows a radial linear bushing to be installed on the side to ensure total utilization of the high load ratings.

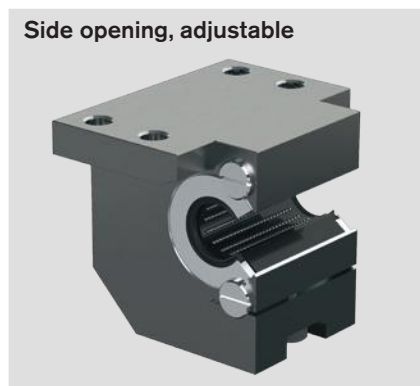

Shaft Ø d (mm)	Material number with two wiper seals LSRSE-...-DD	Weight (kg)
30	R1078 230 20 ¹⁾	7.8
40	R1078 240 20 ¹⁾	15.0
50	R1078 250 20 ¹⁾	27.5
60	R1078 260 20 ¹⁾	48.0
80	R1078 280 20 ¹⁾	105.0

1) Please inquire about delivery time

Explanation of sample short product name

LS	RS	E	30	DD
Linear set	Radial, side opening	Adjustable	Ø 30	With two seals

See page 138 for more information on short product names.

Dimensions

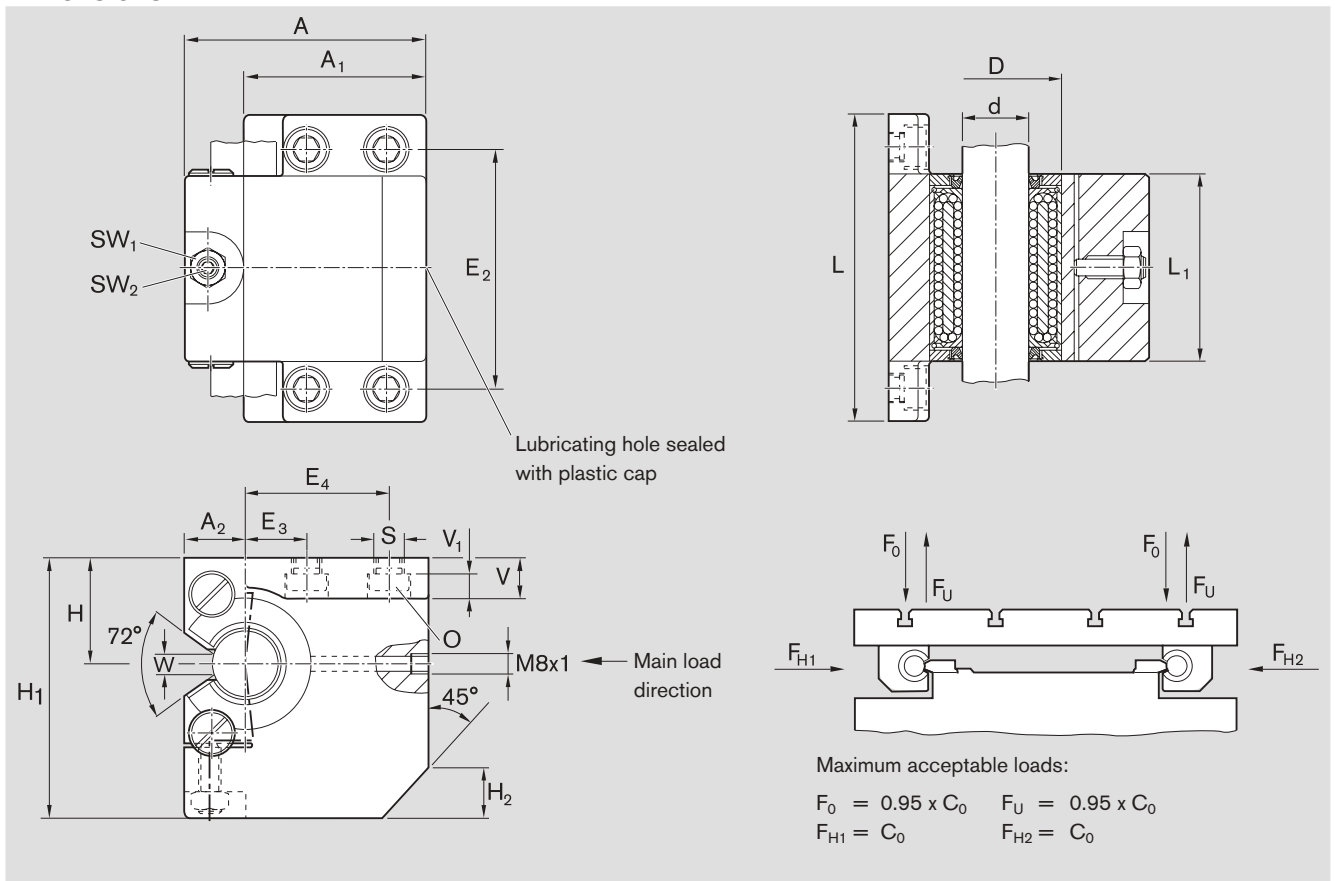

Dimensions (mm)																			
Ø d	D	A1)	A11)	A21)	L ¹⁾	L1 +0.5	H2 ¹⁾	H	H1 ¹⁾	V ¹⁾	V1	E2	E3	E4	S	W ²⁾	SW1	SW2	O ³⁾
30	60	110	83	27	140	84	30	48	118	18	11.0	110	28	65	13.5	14.0	17	5	M12x30
40	75	135	100	35	180	109	35	60	145	25	15.0	142	40	76	17.5	19.5	19	6	M16x40
50	90	165	125	40	230	138	45	70	170	30	17.5	180	50	95	22.0	24.5	24	8	M20x50
60	110	200	150	50	275	163	55	85	205	35	20.5	215	60	115	26.0	29.0	30	10	M24x60
80	145	265	200	65	345	213	70	110	265	45	25.5	275	75	155	33.0	39.0	36	12	M30x80

The dynamic load ratings are based on a total travel of 100,000 m.
 When based on 50,000 m, the C values in the table are multiplied by 1.26.

Shaft Ø d	Radial clearance (µm)	Tolerance For dimension H ⁴⁾ (µm)	Load ratings ⁵⁾ (N)	
			dyn. C	stat. C ₀
30	Comes with an h5 shaft (lower limit) and set to zero clearance	+15	8,500	9,520
		-5		
40		+17	13,900	16,000
		-4		
50		+18	20,800	24,400
		-5		
60		+23	29,500	34,100
		-4		
80		+22	54,800	61,500
		-5		

- 1) Tolerance: js16.
- 2) Minimum size in relation to shaft diameter d.
- 3) DIN 6912-8.8 socket head cap bolts. Recommendation applies for bolting in steel or cast iron threads.
- 4) Clamped (fastened), in relation to nominal shaft dimension d.
- 5) The load ratings apply for the main load direction in the arrow direction F_{H1} or F_{H2} .



Radial compact sets

Technical data, installation

Friction, speed, acceleration, operating temperature, impact of load direction on load rating and rigidity

The values that apply for the radial linear bushing can be used for this design.

Seal friction without radial load

Shaft $\varnothing d$ (mm)	Breakaway force (N) about	Friction (N) about
30	24	12
40	32	16
50	40	20
60	48	24
80	60	30

Installation

Before installation

Make sure the contact surface for the radial compact set is level. Variations impact radial clearance. The shafts must be chamfered. Do not skew the radial compact sets when pushing them onto the shaft.

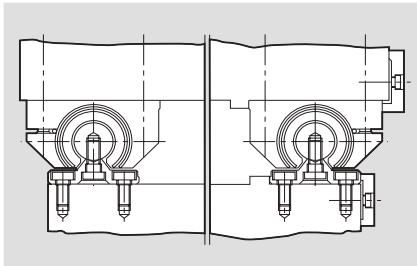

Shaft support rails

See Section "Steel shafts with ready-mounted shaft support rails".

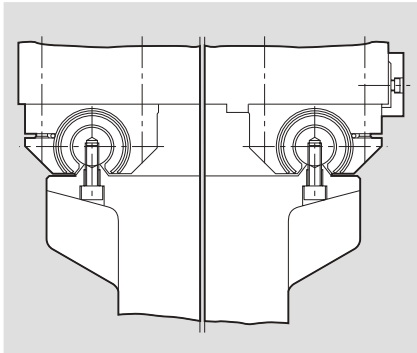

Shaft support rails machined at the machine bed (low height)

- Manufacture shaft support rails according to parallelism requirements (see "Parallelism" under general technical specifications and installation instructions).
- Screw on shafts.
- Install radial compact sets (see Section "Steel shafts with ready-mounted shaft support rails").

Recommended bolts for fastening the shafts

$\varnothing d$ (mm)	ISO 4762-8.8
30	M10x30
40	M12x40
50	M16x50
60	M20x60
80	M24x80

Corner radii, reference edges and bolting

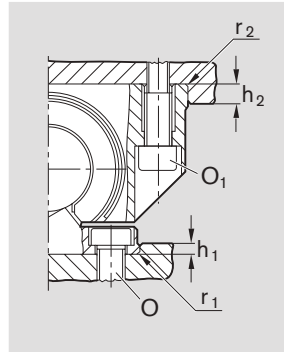

Dimensions (mm)							Tightening torque (Nm)	
Ø d	r ₁ max.	h ₁	r ₂ max.	h ₂	O DIN 7984-8.8	O ₁ ISO 4762-8.8	O	O ₁
30	0.6	6	0.6	6	M10x20	M10x40	32	46
40	0.6	6	0.6	6	M12x25	M12x45	56	80
50	1.2	8	0.6	8	M16x30	M16x60	136	195
60	1.2	8	0.6	16	M20x40	M20x80	270	385
80	1.2	10	0.6	20	M24x50	M24x100	460	660

Radial compact set bolting from bottom

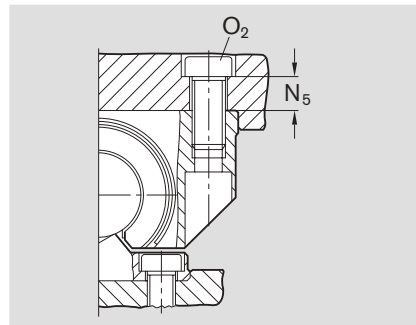

Dimensions (mm)			Tightening torque (Nm)
Ø d	N ₅	O ₂ ISO 4762-8.8	
30	17	M12x30	55
40	24	M16x40	100
50	28	M20x50	240
60	30	M27x60	500
80	45	M30x80	800

Pinned fitting

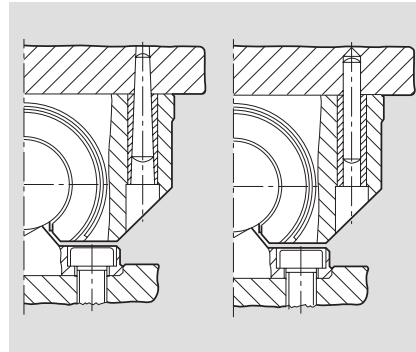

Ø d (mm)	Tapered pin/straight pin (hardened)
30	8x60
40	10x80
50	12x100
60	14x120
80	16x160

Radial clearance

The adjustable radial compact sets come with an h5 shaft (lower limit) and set to zero clearance. If **preload** is desired, proceed as follows:

- Determine the diameter of the guide shaft
- Find and insert an adjusting shaft that is smaller by the degree of preload
- Adjust with the adjusting screw until there is slight resistance when rotating the shaft

Note on lubrication

On-shaft lubrication only until lubricant comes out.



Radial compact sets

Radial compact sets, R1613 Open, adjustable

Design

- Hardened and machined bearing pedestal made of rolling bearing steel
- Ball retainer made of reinforced PA
- Balls made of rolling bearing steel
- Two retaining rings
- Fully sealed (with integrated wiper seals and linear seals)

Open, adjustable



Shaft Ø d (mm)	Material numbers KB-RCS-E-...-VD	Weight (kg)
30	R1613 300 00	1.75
40	R1613 400 00	3.50
50	R1613 500 00	7.10
60	R1613 600 00 ¹⁾	11.90
80	R1613 800 00 ¹⁾	29.60

1) Please inquire about delivery time

Explanation of sample short product name

KB	RCS	E	30	VD
Linear bushing	Radial compact set	Adjustable	Ø 30	Fully sealed

See page 138 for more information on short product names.

Dimensions

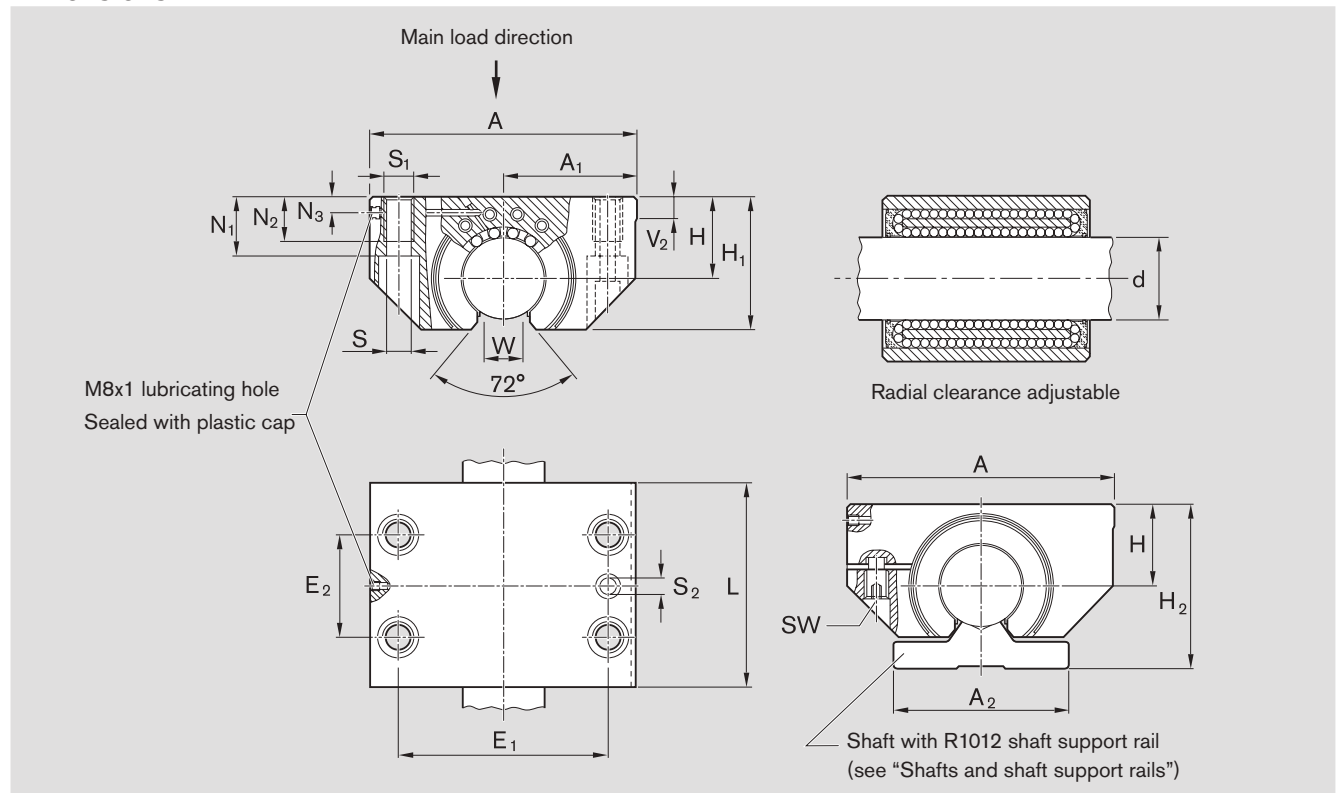

Dimensions (mm)																			Radial clearance (µm)	Load ratings ⁴⁾ (N)	
Ø d	A	A ₁ ±0.008	A ₂	H ¹⁾ ±0.008	H ₁	H ₂	L	E ₁	E ₂	S	S ₁	S ₂ ²⁾	N ₁	N ₂	N ₃	V ₂	W ³⁾	SW		dyn. C	stat. C ₀
30	100	50.0	68	32	53.0	65	75	76	40	10.5	M12	7.7	21	15	9	6	14.0	5	Comes with an h5 shaft (lower limit) and set to zero clearance	8,500	9,520
40	125	62.5	85	40	66.0	80	100	94	50	14.0	M16	9.7	27	18	11	6	19.5	6		13,900	16,000
50	160	80.0	105	50	81.5	100	125	122	65	17.5	M20	11.7	35	24	12	8	24.5	8		20,800	24,400
60	190	95.0	130	60	97.0	120	150	150	75	22.0	M27	13.7	42	32	13	16	29.0	10		29,500	34,100
80	260	130.0	170	80	130.0	160	200	205	100	26.0	M30	15.7	57	36	15	16	39.0	12		54,800	61,500

1) Clamped (fastened), in relation to nominal shaft dimension d.

2) Pre-drilled hole for pinned fitting.

3) Minimum size in relation to shaft diameter d.

4) The load ratings apply for the main load direction $\rho = 0^\circ$.

The dynamic load ratings are based on a total travel of 100,000 m.

When based on 50,000 m, the C values in the table are multiplied by 1.26.



Steel shafts with ready-mounted shaft support rails for radial compact sets

R1012 steel shafts with ready-mounted shaft support rail

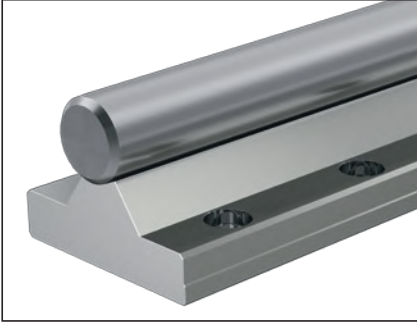

Shaft Ø d (mm)	Material number	Weight (kg/m)
30	R1012 030 ..	12.3
40	R1012 040 ..	19.6
50	R1012 050 ..	31.0
60	R1012 060 .. ¹⁾	45.6
80	R1012 080 .. ¹⁾	79.2

Shafts:

00 = h6 heat-treated steel

30 = h6 stainless steel

60 = h6 hard chrome-plated heat-treated steel

Material

– Shaft support rail: Steel

1) Please inquire about delivery time

Ordering example:

Shaft diameter 40 mm, h6, heat-treated steel, 1,500 mm long, ready-mounted shaft support rail is ordered as:

R1012 040 00/1500 mm.

Dimensions

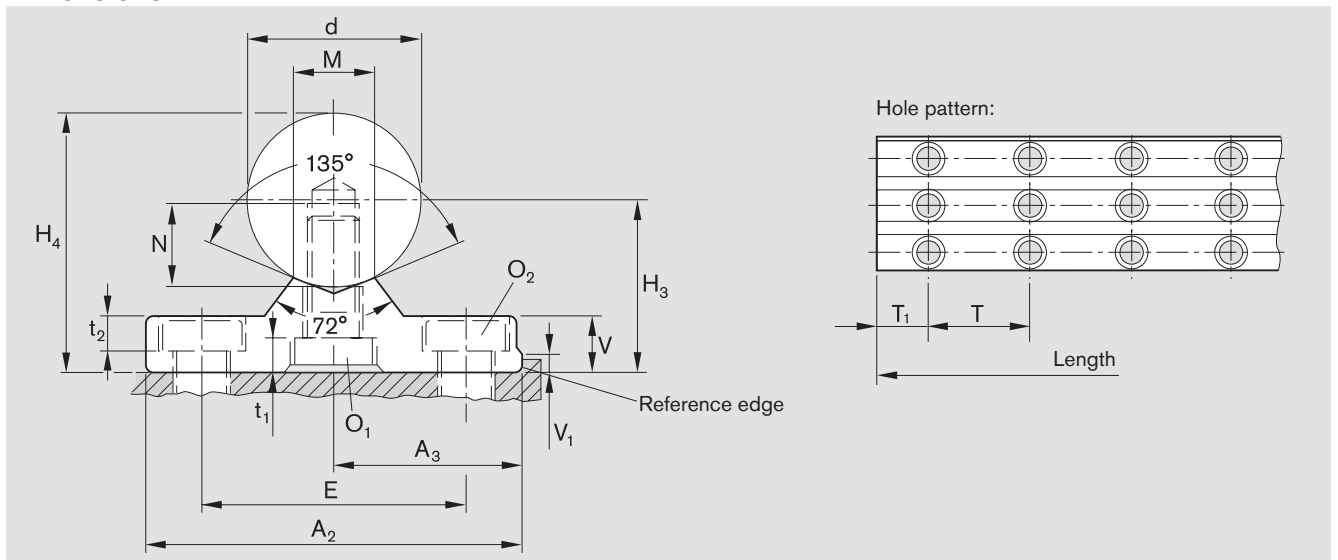

Dimensions (mm)															Grading tolerances (µm)	
Ø d	A ₂	A ₃ ±0.02	H ₃ ¹⁾	H ₄	V	V ₁	M -0.5	E	O ₁ DIN 6912-8.8	t ₁	N	O ₂ DIN 7984-8.8	t ₂	T	H ₃ ²⁾	h6 shaft H ₄ ³⁾
30	68	34.0	33	48	11	6	13	46	M10x25	9.0	17	M10	6.8	60	20 ⁴⁾	29
40	85	42.5	40	60	13	6	18	58	M12x30	10.0	21	M12	8.4	75	20 ⁴⁾	31
50	105	52.5	50	75	17	8	23	74	M16x40	10.8	28	M16	10.5	100	20 ⁴⁾	31
60	130	65.0	60	90	20	8	27	90	M20x40	16.0	32	M20	12.5	120	20	33
80	170	85.0	80	120	26	10	37	120	M24x60	16.0	40	M24	16.0	150	20	33

- 1) Tolerance: ±0.02 mm; comes with a height grade of 20 µm.
- 2) Measured with gauging shaft, nominal dimension d and length about 50 mm.
- 3) Includes shaft tolerance (determined from statistics).
- 4) Up to 1,800 mm length with parallelism of 10 µm available upon request.



Torque-resistant linear bushings

Product overview

The benefits

- For self-supporting, torsion-resistant guides with only one shaft
- 1, 2 or 4 ball guide grooves for transferring torque
- Large variety of forms
- Torque-resistant linear bushings with adjusting screw come set to zero clearance
- Matching shaft profiles with machined ball guide grooves
- Shafts machined to customer specification
- Optional separate wiper seals
- Various flanged versions
- Various steel or aluminum housing versions

Torque-resistant linear bushings

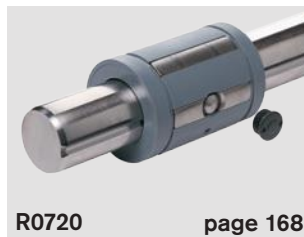
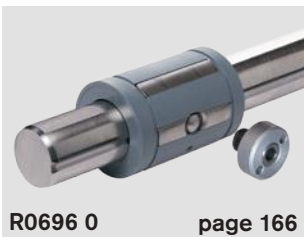
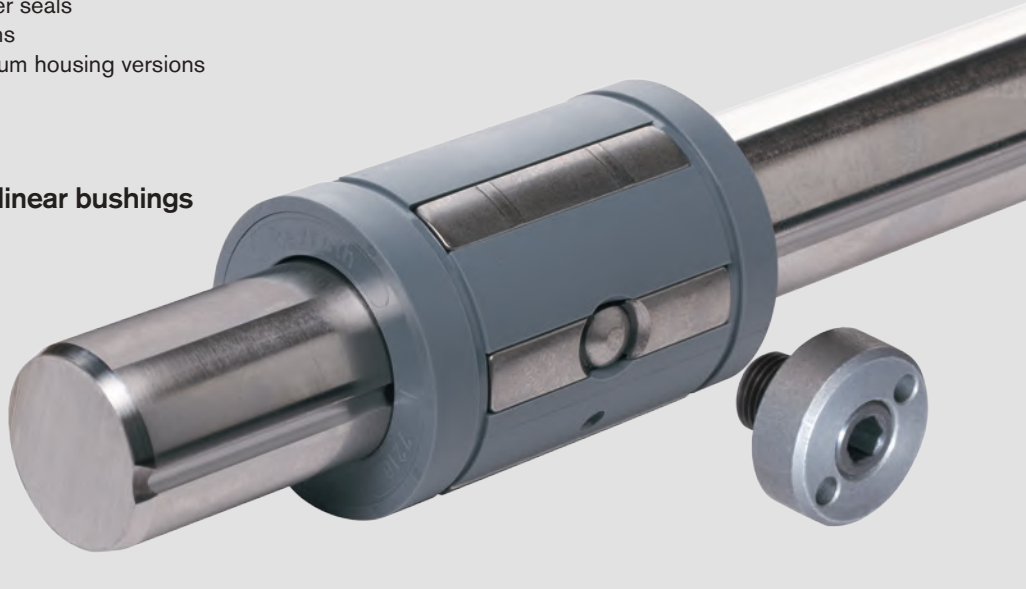

Torque-resistant linear bushing type 1, one ball guide groove

Torque-resistant linear bushing type 2, two ball guide grooves

Torque-resistant compact linear bushing

Explanation of short product name

Sample linear bushing:

Torque-resistant linear bushing with shaft
KBDRC2-20-WV-X90-1200

Definition of codes		KB	DR	C	2	20	WV-X90	1200	
Type	Linear bushing = KB							1200 = Standard length as per table	Shaft length (mm)
Series	Torque = DR							Special = Customized shaft	
	Compact = C							K = Shaft length cut to size	
Track	One ball guide groove = 1							X90 = X90 stainless steel shaft	Shaft
	Two ball guide grooves = 2							WO = Hollow shaft	
Shaft diameter	= 20							WV = Shaft included	

Aluminum housing



R1098 2.. page 170

Type 1: One ball guide groove



R1099 2.. page 172



R1098 5.. page 170

Type 2: Two ball guide grooves



R1099 5.. page 172

Steel housing



R1096 2.. page 174

Type 1: One ball guide groove



R1097 2.. page 176

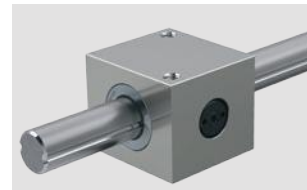

R1096 5.. page 174

Type 2: Two ball guide grooves



R1097 5.. page 176



R0721 page 180



R0722 page 182



R0723 page 184

Installation

⚠ The linear sets come preassembled and set to zero clearance. When pulling out the shaft, the set screws must be loosened and the torque-resistant linear bushing reset.

Sample linear set:

Linear set with torque-resistant linear bushing
LSHDR1T-20-WV-X90-1200

Definition of codes		LS	H	DR	1	T	20	WV-X90	1200	
Type	Linear set	=	LS							
Material (housing)	Steel	=								
	Aluminum	=	A							
Form	Sleeve design	=	H							
	Flanged	=	F							
Series	Torque-resistant linear bushing	=	DR							
Track	One ball guide groove	=	1							
	Two ball guide grooves	=	2							
Housing	Normal	=								
	Tandem	=	T							
Shaft diameter		=	20							
								1200	= Standard length as per table	Shaft length (mm)
								Special	= Customized shaft	
								K	= Shaft length cut to size	Shaft
								X90	= X90 stainless steel shaft	
								WO	= Hollow shaft	
								WV	= Shaft included	



Torque-resistant linear bushings

Product overview

The benefits

- For self-supporting, torsion-resistant guides with only one shaft
- 4 ball guide grooves for transferring torque
- Matching shaft profiles with machined ball guide grooves
- Shafts machined to customer specification
- Various flanged versions

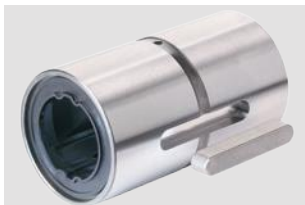

R0724 page 186

Torque-resistant linear bushing Four ball guide grooves

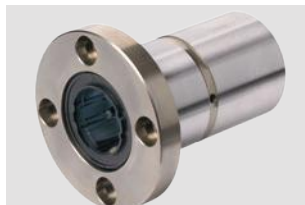

R0725 page 188

Torque-resistant linear bushing Flanged, with four ball guide grooves



R0726 page 188

Torque-resistant linear bushing Miniature flanged, with four ball guide grooves



R0727 page 190

Torque-resistant linear bushing Rotary flanged Four ball guide grooves

Installation

 Linear bushing and shaft for torque-resistant linear bushings with four ball guide grooves come separately. Align the tracks when inserting the shaft and make sure they are not skewed.

Sample linear bushing:

Torque-resistant linear bushing

KBDR4-H-20DD

Definition of codes

Type	Linear bushing	= KB
Series	Torque	= DR
Track	4 ball guide grooves	= 4
	Sleeve design	= H
	Flanged	= F
	Miniature flanged	= FM
	Rotary bearing	= LR

DD	= Two seals	Seal
D	= 1 seal	
	= 20	Size¹

1) Shaft diameter varies (see dimension table)

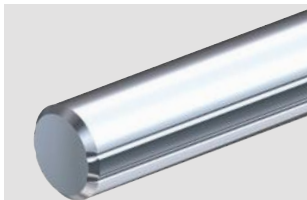

R0724 page 186
Precision steel shaft with four ball guide grooves

Sample shaft:

Shaft, torque-resistant linear bushing

WVDR4-20-1200

Definition of codes

Type	Shaft	= WV	WV	DR	4	20	1200
	Hollow shaft	= WO					
Series	Torque	= DR					
Track	4 ball guide grooves	= 4					
Size¹		= 20					
Shaft length (mm)		= 1200					

1) Shaft diameter varies (see dimension table)



Torque-resistant linear bushings

Technical data

Initial lubrication

Torque-resistant linear bushings do not have an initial lubrication. Grease linear bushings before use, see "Initial lubrication" Section "Lubrication" on page 21. Service life data is based on initial lubrication and relubricated linear bushings.

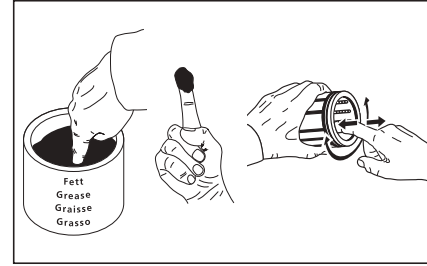

Please observe general technical principles and follow the lubricating and installation instructions.

Speed

$$v_{\max} = 3 \text{ m/s}$$

Acceleration

$$a_{\max} = 150 \text{ m/s}^2$$

Operating temperature

-10 °C to 80 °C

Reduced load rating with short stroke

When short stroke is present, the service life of the shaft is less than that of the torque-resistant linear bushing. The load ratings C in the tables must therefore be multiplied by the factor f_s .

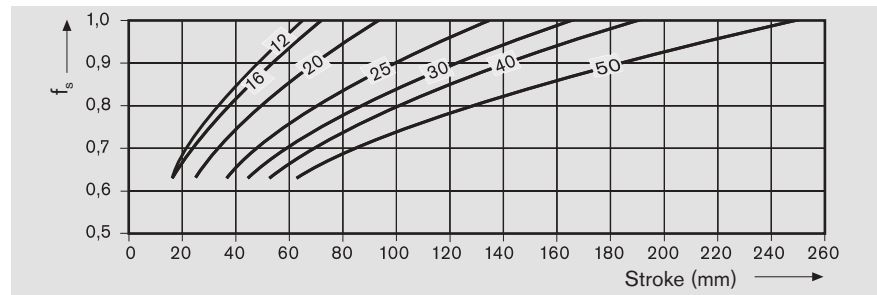

Load rating and service life

When radial load and torque produce the same load, the equivalent total load must be determined for the life expectancy calculation.

$$F_{comb} = F_{res} + C \times \frac{M_x}{M_t}$$

$$L = \left(\frac{C}{F_{comb}} \right)^3 \times 10^5 \text{ m}$$

- F_{comb} = Combined equivalent (N) load
- F_{res} = Resulting radial load (N)
- C = Dynamic load rating (N)
- M_x = Dynamic torque (Nm) around X-axis
- M_t = Dynamic torsional load (Nm) moment
- L = Nominal service life (m)

Service life is calculated as follows under torque load only:

$$M_m = \sqrt[3]{|M_1|^3 \times \frac{q_{s1}}{100\%} + |M_2|^3 \times \frac{q_{s2}}{100\%} + \dots + |M_n|^3 \times \frac{q_{sn}}{100\%}}$$

$$L = \left(\frac{M_t}{M_m} \right)^3 \times 10^5 \text{ m}$$

- $q_1, q_2 \dots q_n$ = Travel ratios for $M_1, M_2, \dots M_n$ (%)
- $M_1, M_2 \dots M_n$ = Stepped individual dynamic loads in stages (Nm)
- M_n = 1 to n (Nm)
- M_t = Dynamic torsional load moment (Nm)
- M_m = equivalent dynamic torque (Nm)
- n = No. stages (-)
- L = Nominal service life (m)

Shaft straightness

- up to 1,200 mm: 0.1 mm
- 2,000 mm: 0.2 mm

Stabilized installation

A fixed mount requires two torque-resistant linear bushings. We recommend the tandem version (with two torque-resistant linear bushings) for the linear sets.



Torque-resistant linear bushings

Installing torque-resistant linear bushings

Installation

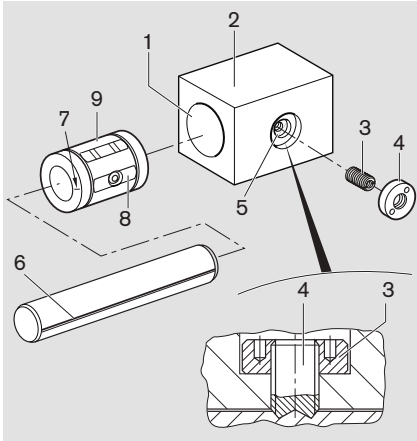

⚠ The linear sets come preassembled and set to zero clearance. When pulling out the shaft, the set screws must be loosened and the torque-resistant linear bushing reset.

- Chamfer and clean the hole (1) in the housing (2).
- Oil the set screw (3).
- Make sure the lock nut (4) can move freely on the set screw (3).
- Make sure the set screw (3) can move freely in the thread (5). Deburr the thread runout if necessary.
- Remove the transport packing from the linear bushing.

⚠ Do not strike the linear bushings with a hammer.

- Place the linear bushing (9) in the housing (2) by hand.
- Align the countersunk steel bearing plate (8) to the thread (5) in the housing.
- Align one ball guide groove (6) to the mark (7) on the labeling field of the linear bushing.
- Insert the shaft **without skewing it**.

Adjusting the set screws

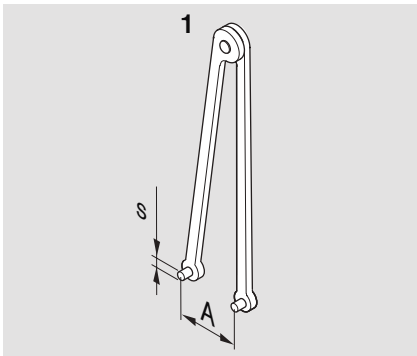

- Tighten the set screw until there is resistance.
- Move the shaft back and forth. While doing so, attempt to turn it in both directions. Use a hexagon screwdriver to tighten the set screw.
- Tighten the set screw to M_{GA} for type 1 (one ball guide groove).
- For type 2 (two ball guide grooves), tighten one set screw to $0.5 \times M_{GA}$, then the other to M_{GA} .
- Secure the set screw with the lock nut. Use a face wrench (1) to do so. Make sure the set screw does not move while tightening the lock nut. Tightening torque = M_{GK} .
- After installation, the friction should be F_R . If the friction is considerably different, loosen and readjust the set screws.
- **Do not attempt to pull the shaft out.**

Shaft Ø d (mm)	Face wrench (1) (mm)		Tightening torque (Ncm) ¹⁾			Friction F_R about (one linear bushing) (N)
	s	A	Set screw M_{GA}	Lock nut M_{GK}		
12	2.5	10.0	8	400	1.5	
16	2.5	10.0	11	400	2.0	
20	3.0	15.0	30	1,500	3.0	
25	3.0	15.0	45	1,500	4.5	
30	3.0	19.5	70	2,000	6.0	
40	3.0	19.5	100	2,000	8.0	
50	3.0	25.0	180	3,000	12.0	

1) Tightening torque at friction factor 0.125

Installing the seal

- Insert the seal onto the shaft and align the lip in the groove.
- Press the seal into the locating hole.

Each installed seal increases the friction above F_R . Two installed seals increases the table value by roughly three times.

Installing torque-resistant compact linear bushings

Installation

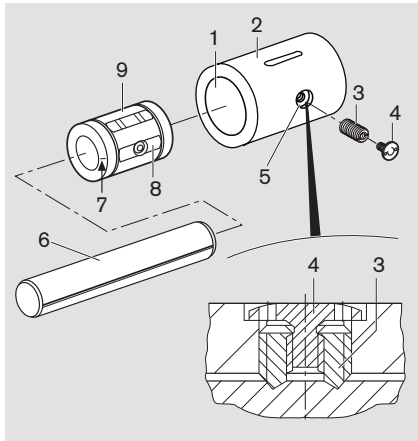

⚠ The linear sets come preassembled and set to zero clearance. When pulling out the shaft, the set screws must be loosened and the torque-resistant linear bushing reset.

- Chamfer and clean the hole (1) in the housing (2).
- Oil set screw (3) and lock screw (4).
- Make sure the lock screw (4) can move freely on the set screw (3).
- Make sure the set screw (3) can move freely in the thread (5). Deburr the thread runout if necessary.
- Remove the transport packing from the linear bushing.

⚠ Do not strike the linear bushings with a hammer.

- Place the linear bushing (9) in the housing (2) by hand.
- Align the countersunk steel bearing plate (8) to the thread (5) in the housing.
- Align one ball guide groove (6) to the mark (7) on the labeling field of the linear bushing.
- Insert the shaft **without skewing it**.

Adjusting the set screws

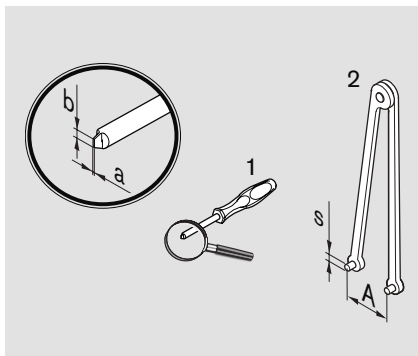

- Tighten the set screw until there is resistance.
- Move the shaft back and forth. While doing so, attempt to turn it in both directions. Use a screwdriver (1) to tighten the set screw.
- Tighten the set screw to M_{GA} for shaft diameters 12 and 16.
- For shaft diameters 20 to 50, tighten one set screw to $0.5 \times M_{GA}$, then the other to M_{GA} .
- Use a face wrench (2) to insert the lock screw into the set screw and tighten it to M_{GK} .
- After installation, the friction should be F_R . If the friction is considerably different, loosen and readjust the set screws.
- **Do not attempt to pull the shaft out.**

Shaft Ø d (mm)	Screwdriver (1) (mm)		Face wrench (2) (mm)		Tightening torque (Ncm) ¹⁾			Friction F_R about (one linear bushing) (N)
	a	b	s	A	Set screw M_{GA}	Lock screw M_{GK}		
12	0.8	5	1.5	5.5	8	110	1.5	
16	0.8	5	1.5	5.5	11	110	2.0	
20	1.0	8	2.0	8.0	30	180	3.8	
25	1.0	8	2.0	8.0	45	380	5.6	
30	1.2	10	2.5	10.0	70	800	7.5	
40	1.2	10	2.5	10.0	100	800	10.0	
50	1.6	14	3.0	13.0	180	1,300	15.0	

1) Tightening torque at friction factor 0.125

Installing the seal

- Insert the seal onto the shaft and align the lip in the groove.
 - Press the seal into the locating hole.
- Each installed seal increases the friction above F_R . Two installed seals increases the table value by roughly three times.



Torque-resistant linear bushings

Torque-resistant linear bushings, R0696 0..
Type 1: One ball guide groove

Torque-resistant linear bushings, R0696 3..
Type 2: Two ball guide grooves

Design

- Ball retainer and outer sleeve made of PA or POM
- Hardened steel bearing plates

- Balls made of rolling bearing steel
- Precision steel shaft with ball guide groove
- Hardened steel set screw
- Steel lock nut



Shaft Ø d (mm)	Material number for torque-resistant linear bushing with shaft		
	Standard length as per table	Shaft length cut to size ¹	Customized shaft
	KBDR1- ... -WV- ...	KBDR1- ... -K	KBDR1- ... -SPECIAL
12	R0696 012 80	R0696 012 89	R0696 012 86
16	R0696 016 80	R0696 016 89	R0696 016 86
20	R0696 020 80	R0696 020 89	R0696 020 86
25	R0696 025 80	R0696 025 89	R0696 025 86
30	R0696 030 80	R0696 030 89	R0696 030 86
40	R0696 040 80	R0696 040 89	R0696 040 86
50	R0696 050 80	R0696 050 89	R0696 050 86

- 85 Shaft length 900 mm
- 87 Shaft length 1,200 mm
- 88 Shaft length 2,000 mm

Material number for torque-resistant linear bushing without shaft: R0696 0.. 00



Shaft Ø d (mm)	Material number for torque-resistant linear bushing with shaft		
	Standard length as per table	Shaft length cut to size ¹	Customized shaft
	KBDR2- ... -WV- ...	KBDR2- ... -K	KBDR2- ... -SPECIAL
20	R0696 320 80	R0696 320 89	R0696 320 86
25	R0696 325 80	R0696 325 89	R0696 325 86
30	R0696 330 80	R0696 330 89	R0696 330 86
40	R0696 340 80	R0696 340 89	R0696 340 86
50	R0696 350 80	R0696 350 89	R0696 350 86

- 85 Shaft length 900 mm
- 87 Shaft length 1,200 mm
- 88 Shaft length 2,000 mm

Material number for torque-resistant linear bushing without shaft: R0696 3.. 00

1) Also available with hollow shaft for shaft diameters 25 and higher: R0696 ... 69 or with ISO 683-17/EN 10088 stainless steel solid shaft: R0696 ... 79.



Shaft Ø d (mm)	Material number		Weight (g)
	Type 1	Type 2	
12	R1331 112 00	-	1.6
16	R1331 116 00	-	2.0
20	R1331 120 00	R1331 320 00	4.5
25	R1331 125 00	R1331 325 00	6.6
30	R1331 130 00	R1331 330 00	9.3
40	R1331 140 00	R1331 340 00	17.0
50	R1331 150 00	R1331 350 00	24.0

Wiper seal must be ordered separately.

Explanation of sample short product name

KB	DR	2	25	WV	2000
Linear bushing	Torque	Two ball guide grooves	Ø 25	Shaft included	2000

See page 158 for more information on short product names.

Dimensions

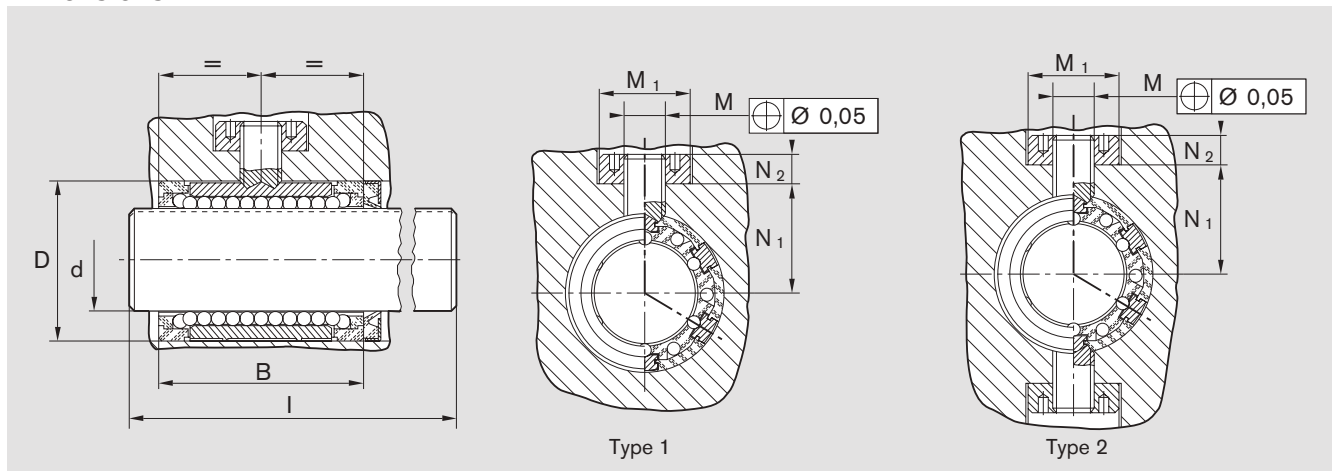

Dimensions (mm)								Standard length (mm)	Torsional load moment M_t (Nm)		Load ratings ² (N)		Weight	
Type 1	Type 2	$D^{1)}$	B	M	M_1 +0.1	N_1	N_2		Type 1	Type 2	dyn. C	stat. C_0	Linear bushing (kg)	Shaft (kg/m)
12	-	22	32	M6x0.5	14	15.5	5.0	400	2.0	-	640	420	0.026	0.89
16	-	26	36	M6x0.5	14	19.5	5.0	400	3.3	-	780	530	0.032	1.57
20	20	32	45	M10x1	22	21.5	8.0	500	7.5	12	1,550	1,050	0.064	2.45
25	25	40	58	M10x1	22	28.5	8.0	500	15.0	24	3,030	2,180	0.135	3.80
30	30	47	68	M12x1	26	32.0	9.5	600	23.0	37	3,680	2,790	0.210	5.50
40	40	62	80	M12x1	26	44.0	9.5	600	53.0	86	6,320	4,350	0.390	9.80
50	50	75	100	M16x1.5	34	52.0	12.5	600	103.0	167	9,250	6,470	0.680	15.30

1) Recommended installation bore: D^{JS7} .

2) The load ratings indicated are minimal values as the load direction cannot be clearly defined.

The dynamic load ratings are based on a total travel of 100,000 m.

When based on 50,000 m, the C values in the table are multiplied by 1.26.

Wiper seal

Design

- Galvanized metal case
- Elastomer wiper seal

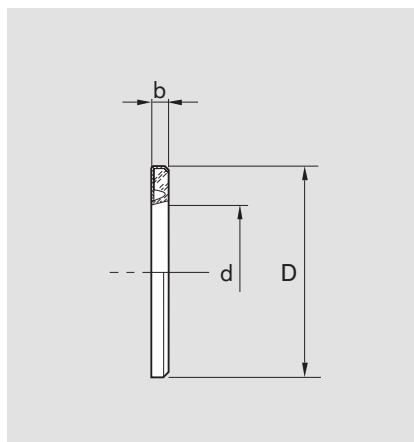

Dimensions (mm)		
$\varnothing d$	$D^{3)}$	b +0.3
12	22	3
16	26	3
20	32	4
25	40	4
30	47	5
40	62	5
50	75	6

3) Outer diameter D is oversized by about 0.1 mm.

No additional securing is needed.

Torque-resistant compact linear bushings

Torque-resistant compact linear bushings, R0720

Design

- Ball retainer and outer sleeve made of PA or POM
 - Hardened steel bearing plates
 - Balls made of rolling bearing steel
 - Precision steel shaft with ball guide groove
 - Hardened steel set screw
 - Steel lock nut
- **One ball guide groove for diameter shafts 12 and 16 mm**
 - **Two ball guide grooves for diameter shafts 20 mm and higher**



Shaft Ø d (mm)	Material number for torque-resistant linear bushing with shaft		
	Standard length as per table KBDRC.- ... -WV- ...	Shaft length cut to size ¹ KBDRC.- ... -WV-K	Customized shaft KBDRC.- ... -SPECIAL
12	R0720 012 80	R0720 012 89	R0720 012 86
16	R0720 016 80	R0720 016 89	R0720 016 86
20	R0720 320 80	R0720 320 89	R0720 320 86
25	R0720 325 80	R0720 325 89	R0720 325 86
30	R0720 330 80	R0720 330 89	R0720 330 86
40	R0720 340 80	R0720 340 89	R0720 340 86
50	R0720 350 80	R0720 350 89	R0720 350 86

- 85 Shaft length 900 mm
- 87 Shaft length 1,200 mm
- 88 Shaft length 2,000 mm

Material number for torque-resistant compact linear bushing without shaft:

Shaft diameters 12 and 16: R0720 0.. 00

Shaft diameters 20 to 50: R0720 3.. 00

1) Also available with hollow shaft for shaft diameters 25 and higher: R0720 ... 69 or with ISO 683-17/EN 10088 stainless steel solid shaft: R0720 ... 79.



Wiper seals

Shaft Ø d (mm)	Material number Wiper seals	Weight (g)
12	R1331 112 00	1.6
16	R1331 116 00	2.0
20	R1331 320 00	4.5
25	R1331 325 00	6.6
30	R1331 330 00	9.3
40	R1331 340 00	17.0
50	R1331 350 00	24.0

Wiper seal must be ordered separately.

Explanation of sample short product name

KB	DR	C	2	20	WV	1200
Linear bushing	Torque	Compact	Two ball guide grooves	Ø 20	Shaft included	1,200 mm

See page 158 for more information on short product names.

Dimensions

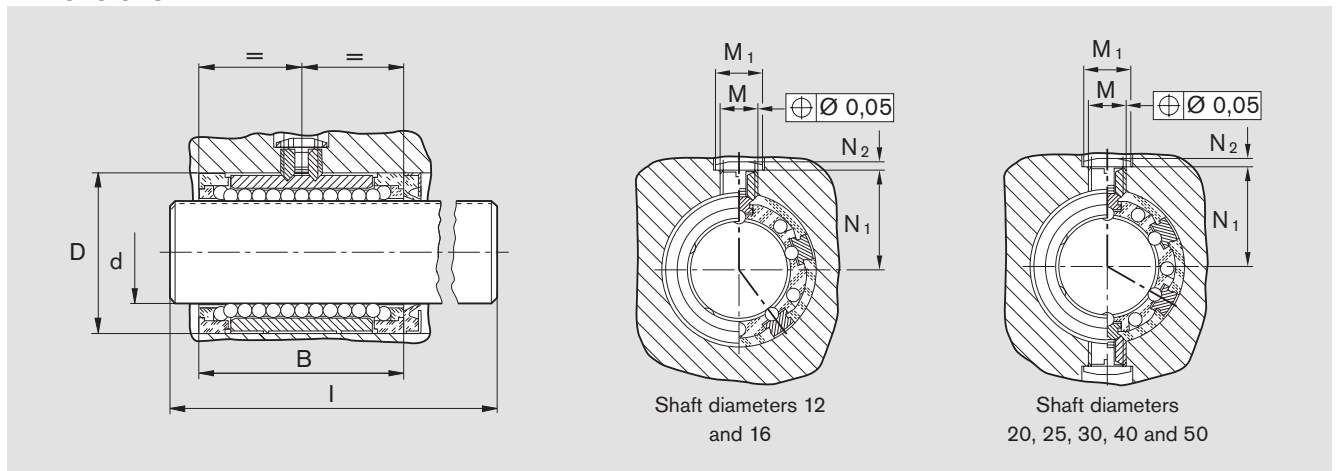

Dimensions (mm)							Standard length l (mm)	Torsional load moment M_t (Nm)	Load ratings ² (N)		Weight	
$\varnothing d$	D ¹⁾	B	M	M ₁	N ₁ +0.1	N ₂			dyn. C	stat. C ₀	Linear bushing (kg)	Shaft (kg/m)
12	22	32	M6x0.5	8.0	14.4	1.3	400	2.0	640	420	0.026	0.89
16	26	36	M6x0.5	8.0	16.4	1.3	400	3.3	780	530	0.032	1.57
20	32	45	M10x1	12.5	21.8	1.9	500	12.0	1,550	1,050	0.071	2.45
25	40	58	M10x1	12.5	25.8	1.9	500	24.0	3,030	2,180	0.130	3.80
30	47	68	M12x1	15.0	29.7	2.5	600	37.0	3,680	2,790	0.200	5.50
40	62	80	M12x1	15.0	37.2	2.5	600	86.0	6,320	4,350	0.380	9.80
50	75	100	M16x1.5	20.0	46.7	3.0	600	167.0	9,250	6,470	0.620	15.30

1) Recommended installation bore: D^{K6}.

2) The load ratings indicated are minimal values as the load direction cannot always be clearly defined.

The dynamic load ratings are based on a total travel of 100,000 m.

When based on 50,000 m, the C values in the table are multiplied by 1.26.

Wiper seal

Design

- Galvanized metal case
- Elastomer wiper seal

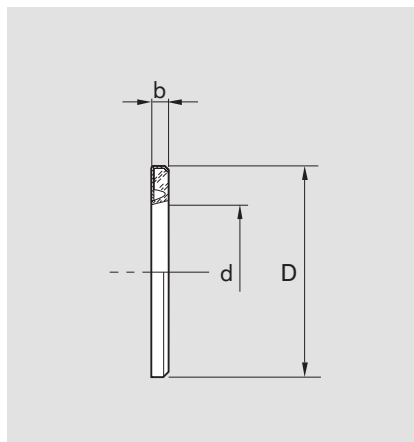

Dimensions (mm)		
$\varnothing d$	D ³⁾	b +0.3
12	22	3
16	26	3
20	32	4
25	40	4
30	47	5
40	62	5
50	75	6

3 Outer diameter D is oversized by about 0.1 mm.

No additional securing is needed.

Linear sets with torque-resistant linear bushings aluminum housing

Linear sets, R1098 2..

Type 1: One ball guide groove

Linear sets, R1098 5..

Type 2: Two ball guide grooves

Design

- Lightweight precision housing (aluminum)
- Torque-resistant linear bushing
- Precision steel shaft with ball guide groove
- Torque-transmitting, hardened steel bearing plates come set to zero clearance
- Top wiper seals
- Stabilized version: see Linear sets, tandem
- Relubricatable

Type 1: One ball guide groove



Shaft Ø d (mm)	Material number for linear set with shaft		
	Standard length as per table	Shaft length cut to size ¹	Customized shaft
	LSADR1- ... -WV- ...	LSADR1- ... -WV-K	LSADR1- ... -SPECIAL
12	R1098 212 80	R1098 212 89	R1098 212 86
16	R1098 216 80	R1098 216 89	R1098 216 86
20	R1098 220 80	R1098 220 89	R1098 220 86
25	R1098 225 80	R1098 225 89	R1098 225 86
30	R1098 230 80	R1098 230 89	R1098 230 86
40	R1098 240 80	R1098 240 89	R1098 240 86
50	R1098 250 80	R1098 250 89	R1098 250 86

- 85 Shaft length 900 mm
- 87 Shaft length 1,200 mm
- 88 Shaft length 2,000 mm

Type 2: Two ball guide grooves



Shaft Ø d (mm)	Material number for linear set with shaft		
	Standard length as per table	Shaft length cut to size ¹	Customized shaft
	LSADR2- ... -WV- ...	LSADR2- ... -WV-K	LSADR2- ... -SPECIAL
20	R1098 520 80	R1098 520 89	R1098 520 86
25	R1098 525 80	R1098 525 89	R1098 525 86
30	R1098 530 80	R1098 530 89	R1098 530 86
40	R1098 540 80	R1098 540 89	R1098 540 86
50	R1098 550 80	R1098 550 89	R1098 550 86

- 85 Shaft length 900 mm
- 87 Shaft length 1,200 mm
- 88 Shaft length 2,000 mm

1) Also available with hollow shaft for shaft diameters 25 and higher: R1098 ... 69 or with ISO 683-17/EN 10088 stainless steel solid shaft: R1098 ... 79.

Explanation of sample short product name

LS	A	DR	1	12	WV	1200
Linear set	Aluminum	Torque	One ball guide groove	Ø 12	Shaft included	1,200 mm

See page 159 for more information on short product names.

Dimensions

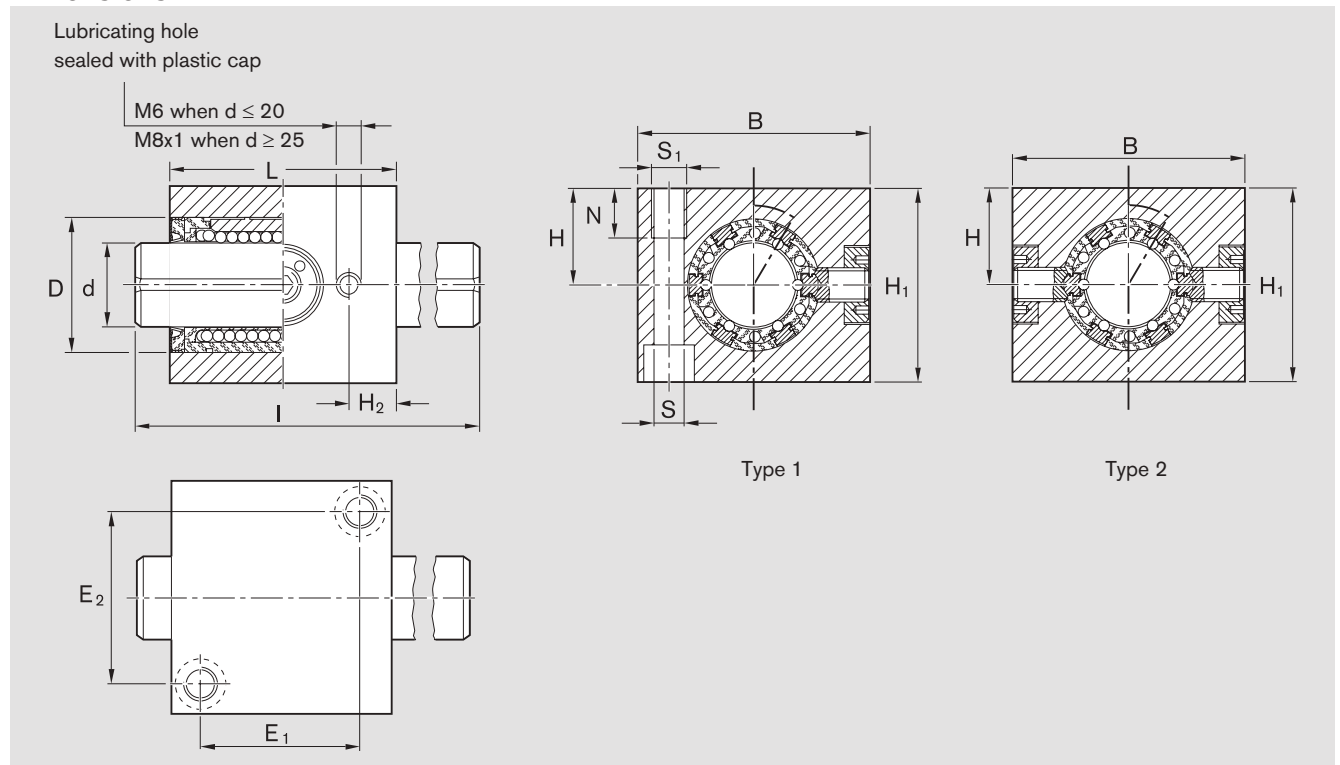

Dimensions (mm)													Standard length I (mm)	Torsional load moment M_t (Nm)		Load ratings ³⁾ (N)		Weight Linear set (kg)	Shaft (kg/m)
Type 1	Type 2	B	H ₁	H ¹⁾ +0.013 -0.022	H ₂	L	D	E ₁	E ₂	S ²⁾	S ₁	N		Type 1	Type 2	dyn. C	stat. C ₀		
12	-	42	35	18	8.5	40	22	28	30	5.3	M6	12	400	2.0	-	640	420	0.15	0.89
16	-	50	42	22	10.0	44	26	30	36	5.3	M6	12	400	3.3	-	780	530	0.22	1.57
20	20	60	50	25	11.0	55	32	39	44	6.6	M8	12	500	7.5	12	1,550	1,050	0.42	2.45
25	25	74	60	30	15.5	68	40	48	54	8.4	M10	15	500	15.0	24	3,030	2,180	0.70	3.80
30	30	84	70	35	16.5	80	47	58	62	10.5	M12	18	600	23.0	37	3,680	2,790	1.10	5.50
40	40	108	90	45	18.5	92	62	64	80	13.5	M16	20	600	53.0	86	6,320	4,350	2.10	9.80
50	50	130	105	50	22.5	114	75	84	100	13.5	M16	20	600	103.0	167	9,250	6,470	3.50	15.30

- 1) Two or more linear sets on one shaft are machined to the same dimension H while installed. Dimension H is reduced by 0.5 mm.
- 2) ISO 4762-8.8 fastening bolts.
- 3) The load ratings indicated are minimal values as the load direction cannot always be clearly defined.

The dynamic load ratings are based on a total travel of 100,000 m.
When based on 50,000 m, the C values in the table are multiplied by 1.26.

Note on lubrication: On-shaft lubrication via lubricating hole until lubricant comes out.



Linear sets with torque-resistant linear bushings, aluminum housing

Tandem

Linear sets, R1099 2..

Type 1: One ball guide groove

Linear sets, R1099 5..

Type 2: Two ball guide grooves

Design

- Lightweight precision tandem housing (aluminum)
- Two torque-resistant linear bushings
- Precision steel shaft with ball guide groove
- Torque-transmitting, hardened steel bearing plates come set to zero clearance
- Top wiper seals
- Stabilized version
- Relubricatable



Shaft Ø d (mm)	Material number for linear set with shaft		
	Standard length as per table	Shaft length cut to size ¹	Customized shaft
	LSADR1T- ... -WV- ...	LSADR1T- ... -WV-K	LSADR1T- ... -SPECIAL
12	R1099 212 80	R1099 212 89	R1099 212 86
16	R1099 216 80	R1099 216 89	R1099 216 86
20	R1099 220 80	R1099 220 89	R1099 220 86
25	R1099 225 80	R1099 225 89	R1099 225 86
30	R1099 230 80	R1099 230 89	R1099 230 86
40	R1099 240 80	R1099 240 89	R1099 240 86
50	R1099 250 80	R1099 250 89	R1099 250 86

- 85 Shaft length 900 mm
- 87 Shaft length 1,200 mm
- 88 Shaft length 2,000 mm



Shaft Ø d (mm)	Material number for linear set with shaft		
	Standard length as per table	Shaft length cut to size ¹	Customized shaft
	LSADR2T- ... -WV- ...	LSADR2T- ... -WV-K	LSADR2T- ... -SPECIAL
20	R1099 520 80	R1099 520 89	R1099 520 86
25	R1099 525 80	R1099 525 89	R1099 525 86
30	R1099 530 80	R1099 530 89	R1099 530 86
40	R1099 540 80	R1099 540 89	R1099 540 86
50	R1099 550 80	R1099 550 89	R1099 550 86

- 85 Shaft length 900 mm
- 87 Shaft length 1,200 mm
- 88 Shaft length 2,000 mm

1) Also available with hollow shaft for shaft diameters 25 and higher: R1099 ... 69 or with ISO 683-17/EN 10088 stainless steel solid shaft: R1099 ... 79.

Explanation of sample short product name

LS	A	DR	2	T	20	WV	2000
Linear set	Aluminum	Torque	Two ball guide grooves	Tandem	Ø 20	Shaft included	2,000 mm

See page 159 for more information on short product names.

Dimensions

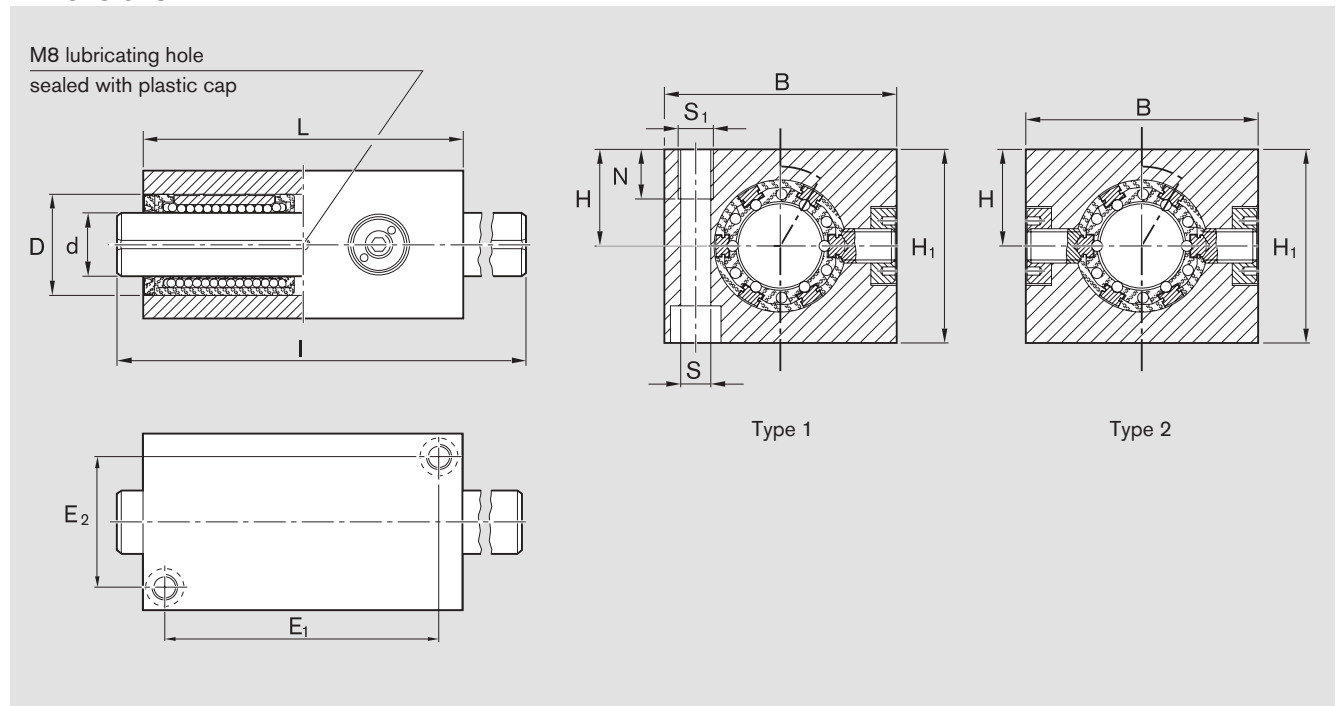

Dimensions (mm)												Standard length I (mm)	Torsional load moment M_t (Nm)		Load ratings ³⁾ (N)		Weight Linear set (kg)	Shaft (kg/m)
Type 1	Type 2	B	H ₁	H ¹⁾ +0.013 -0.022	L	D	E ₁	E ₂	S ²⁾	S ₁	N		Type 1	Type 2	dyn. C	stat. C ₀		
12	-	42	35	18	76	22	64	30	5.3	M6	12	400	3.2	-	1,040	840	0.29	0.89
16	-	50	42	22	84	26	70	36	5.3	M6	12	400	5.5	-	1,260	1,060	0.43	1.57
20	20	60	50	25	104	32	88	44	6.6	M8	12	500	12.0	20	2,500	2,100	0.80	2.45
25	25	74	60	30	130	40	110	54	8.4	M10	15	500	24.0	40	4,900	4,360	1.50	3.80
30	30	84	70	35	152	47	130	62	10.5	M12	18	600	37.0	60	6,000	5,580	2.20	5.50
40	40	108	90	45	176	62	148	80	13.5	M16	20	600	86.0	140	10,200	8,700	4.00	9.80
50	50	130	105	50	224	75	194	100	13.5	M16	20	600	167.0	272	15,000	12,940	6.90	15.30

- 1) Two or more linear sets on one shaft are machined to the same dimension H while installed.
Dimension H is reduced by 0.5 mm.
- 2) ISO 4762-8.8 fastening bolts.
- 3) Load rating when both linear bushings are under equal load.
The load ratings indicated are minimal values as the load direction cannot always be clearly defined.

The dynamic load ratings are based on a total travel of 100,000 m.
When based on 50,000 m, the C values in the table are multiplied by 1.26.

Note on lubrication: On-shaft lubrication via lubricating hole until lubricant comes out.



Linear sets with torque-resistant linear bushings, steel housing

Linear sets, R1096 2..

Type 1: One ball guide groove

Linear sets, R1096 5..

Type 2: Two ball guide grooves

Design

- Steel precision housing
- Torque-resistant linear bushing
- Precision steel shaft with ball guide groove
- Torque-transmitting, hardened steel bearing plates come set to zero clearance
- Top wiper seals
- Stabilized version: see Linear sets, tandem



Shaft Ø d (mm)	Material number for linear set with shaft		
	Standard length as per table	Shaft length cut to size ¹	Customized shaft
	LSSDR1-...-WV- ...	LSSDR1- ... -WV-K	LSSDR1- ... -SPECIAL
12	R1096 212 80	R1096 212 89	R1096 212 86
16	R1096 216 80	R1096 216 89	R1096 216 86
20	R1096 220 80	R1096 220 89	R1096 220 86
25	R1096 225 80	R1096 225 89	R1096 225 86
30	R1096 230 80	R1096 230 89	R1096 230 86
40	R1096 240 80	R1096 240 89	R1096 240 86
50	R1096 250 80	R1096 250 89	R1096 250 86

- 85 Shaft length 900 mm
- 87 Shaft length 1,200 mm
- 88 Shaft length 2,000 mm



Shaft Ø d (mm)	Material number for linear set with shaft		
	Standard length as per table	Shaft length cut to size ¹	Customized shaft
	LSSDR2- ... -WV- ...	LSSDR2- ... -WV-K	LSSDR2- ... -SPECIAL
20	R1096 520 80	R1096 520 89	R1096 520 86
25	R1096 525 80	R1096 525 89	R1096 525 86
30	R1096 530 80	R1096 530 89	R1096 530 86
40	R1096 540 80	R1096 540 89	R1096 540 86
50	R1096 550 80	R1096 550 89	R1096 550 86

- 85 Shaft length 900 mm
- 87 Shaft length 1,200 mm
- 88 Shaft length 2,000 mm

1) Also available with hollow shaft for shaft diameters 25 and higher: R1096 ... 69 or with ISO 683-17/EN 10088 stainless steel solid shaft: R1096 ... 79.

Explanation of sample short product name

LS	S	DR	2	20	WV	2000
Linear set	Steel	Torque	Two ball guide grooves	Ø 20	Shaft included	2,000 mm

See page 159 for more information on short product names.

Dimensions

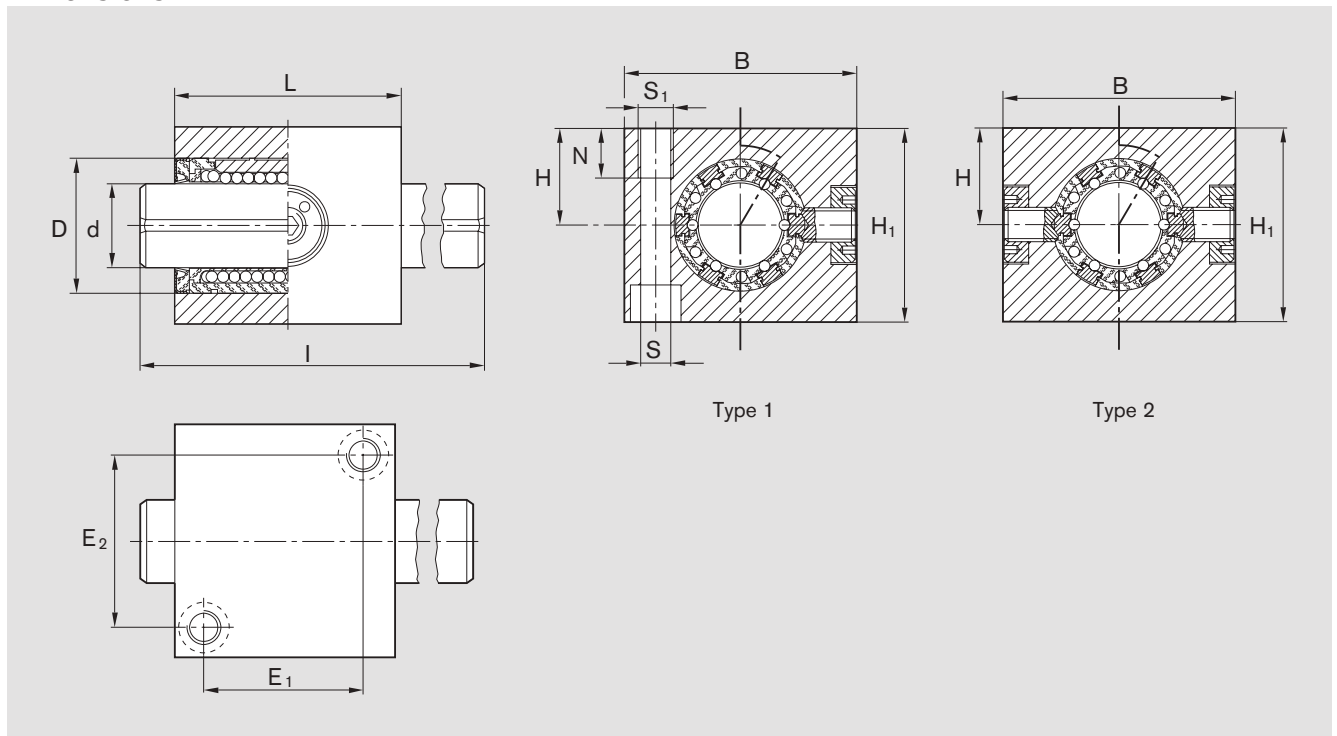

Dimensions (mm)													Standard length I (mm)	Torsional load moment M_t (Nm)		Load ratings ³⁾		Weight Linear set (kg)	Shaft (kg/m)
Type 1	Type 2	B	H ₁	H ¹⁾ +0.013 -0.022	L	D	E ₁	E ₂	S ²⁾	S ₁	N	Type 1		Type 2	dyn. C	stat. C ₀			
12	-	42	35	18	40	22	28	30	5.3	M6	12	400	2.0	-	640	420	0.35	0.89	
16	-	50	42	22	44	26	30	36	5.3	M6	12	400	3.3	-	780	530	0.55	1.57	
20	20	60	50	25	55	32	39	44	6.6	M8	12	500	7.5	12	1,550	1,050	1.00	2.45	
25	25	74	60	30	68	40	48	54	8.4	M10	15	500	15.0	24	3,030	2,180	1.50	3.80	
30	30	84	70	35	80	47	58	62	10.5	M12	18	600	23.0	37	3,680	2,790	2.70	5.50	
40	40	108	90	45	92	62	64	80	13.5	M16	20	600	53.0	86	6,320	4,350	5.00	9.80	
50	50	130	105	50	114	75	84	100	13.5	M16	20	600	103.0	167	9,250	6,470	8.70	15.30	

- 1) Two or more linear sets on one shaft are machined to the same dimension H while installed. Dimension H is reduced by 0.5 mm.
- 2) ISO 4762-8.8 fastening bolts.
- 3) The load ratings indicated are minimal values as the load direction cannot always be clearly defined.

The dynamic load ratings are based on a total travel of 100,000 m.
When based on 50,000 m, the C values in the table are multiplied by 1.26.



Linear sets with torque-resistant linear bushings, steel housing

Tandem

Linear sets, R1097 2..

Type 1: One ball guide groove

Linear sets, R1097 5..

Type 2: Two ball guide grooves

Design

- Steel precision tandem housing
- Two torque-resistant linear bushings
- Precision steel shaft with ball guide groove
- Torque-transmitting, hardened steel bearing plates come set to zero clearance
- Top wiper seals
- Stabilized version

Type 1: One ball guide groove



Shaft Ø d (mm)	Material number for linear set with shaft		
	Standard length as per table	Shaft length cut to size ¹	Customized shaft
	LSSDR1T- ... -WV- ...	LSSDR1T- ... -WV-K	LSSDR1T- ... -SPECIAL
12	R1097 212 80	R1097 212 89	R1097 212 86
16	R1097 216 80	R1097 216 89	R1097 216 86
20	R1097 220 80	R1097 220 89	R1097 220 86
25	R1097 225 80	R1097 225 89	R1097 225 86
30	R1097 230 80	R1097 230 89	R1097 230 86
40	R1097 240 80	R1097 240 89	R1097 240 86
50	R1097 250 80	R1097 250 89	R1097 250 86

- 85 Shaft length 900 mm
- 87 Shaft length 1,200 mm
- 88 Shaft length 2,000 mm

Type 2: Two ball guide grooves



Shaft Ø d (mm)	Material number for linear set with shaft		
	Standard length as per table	Shaft length cut to size ¹	Customized shaft
	LSSDR2T- ... -WV- ...	LSSDR2T- ... -WV-K	LSSDR2T- ... -SPECIAL
20	R1097 520 80	R1097 520 89	R1097 520 86
25	R1097 525 80	R1097 525 89	R1097 525 86
30	R1097 530 80	R1097 530 89	R1097 530 86
40	R1097 540 80	R1097 540 89	R1097 540 86
50	R1097 550 80	R1097 550 89	R1097 550 86

- 85 Shaft length 900 mm
- 87 Shaft length 1,200 mm
- 88 Shaft length 2,000 mm

1) Also available with hollow shaft for shaft diameters 25 and higher: R1097 ... 69 or with ISO 683-17/EN 10088 stainless steel solid shaft: R1097 ... 79.

Explanation of sample short product name

LS	S	DR	2	T	20	WV	2000
Linear set	Steel	Torque	Two ball guide grooves	Tandem	Ø 20	Shaft included	2,000 mm

See page 159 for more information on short product names.

Dimensions

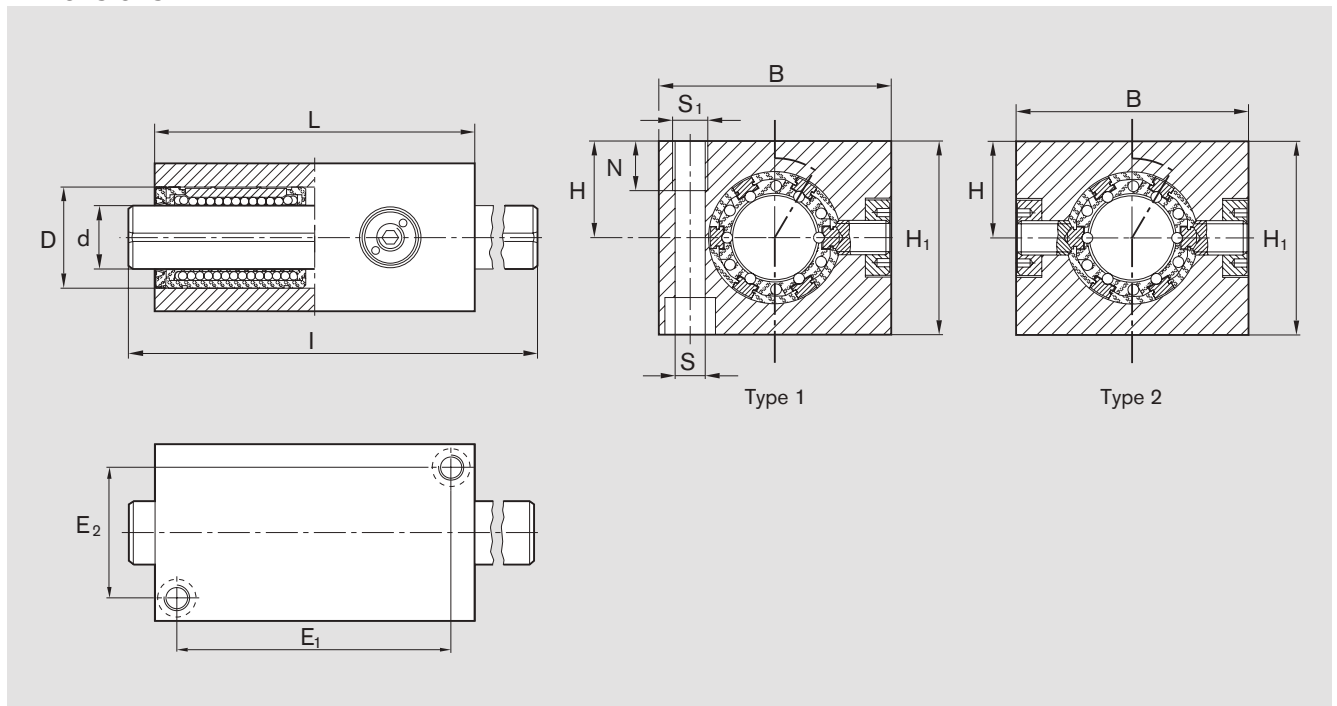

Dimensions (mm)												Standard length I (mm)	Torsional load moment M_t (Nm)		Load ratings ³⁾ (N)		Weight Linear set (kg)	Shaft (kg/m)
Type 1	Type 2	B	H ₁	H ¹⁾ +0.013 -0.022	L	D	E ₁	E ₂	S ²⁾	S ₁	N		Type 1	Type 2	dyn. C	stat. C ₀		
12	-	42	35	18	76	22	64	30	5.3	M6	12	400	3.2	-	1,040	840	0.7	0.89
16	-	50	42	22	84	26	70	36	5.3	M6	12	400	5.5	-	1,260	1,060	1.0	1.57
20	20	60	50	25	104	32	88	44	6.6	M8	12	500	12.0	20	2,500	2,100	1.9	2.45
25	25	74	60	30	130	40	110	54	8.4	M10	15	500	24.0	40	4,900	4,360	3.5	3.80
30	30	84	70	35	152	47	130	62	10.5	M12	18	600	37.0	60	6,000	5,580	5.2	5.50
40	40	108	90	45	176	62	148	80	13.5	M16	20	600	86.0	140	10,200	8,700	9.8	9.80
50	50	130	105	50	224	75	194	100	13.5	M16	20	600	167.0	272	15,000	12,940	17.0	15.30

- 1) Two or more linear sets on one shaft are machined to the same dimension H while installed.
Dimension H is reduced by 0.5 mm.
- 2) ISO 4762-8.8 fastening bolts.
- 3) Load rating when both linear bushings are under equal load.
The load ratings indicated are minimal values as the load direction cannot always be clearly defined.

The dynamic load ratings are based on a total travel of 100,000 m.
When based on 50,000 m, the C values in the table are multiplied by 1.26.



Linear sets with torque-resistant compact linear bushings

Installation

- Recommendations for installation, arranging the lubricating channels and holes, and securing
- Recommended mounting bore: D^{H6} (D^{J6})

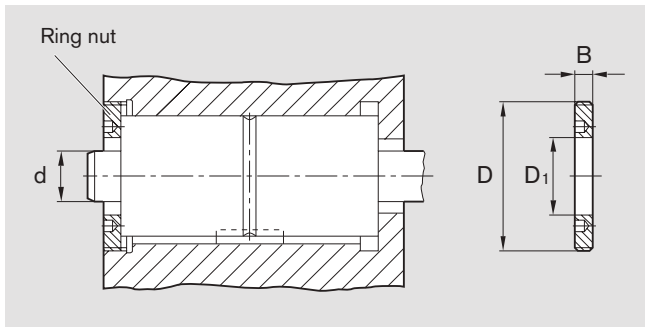
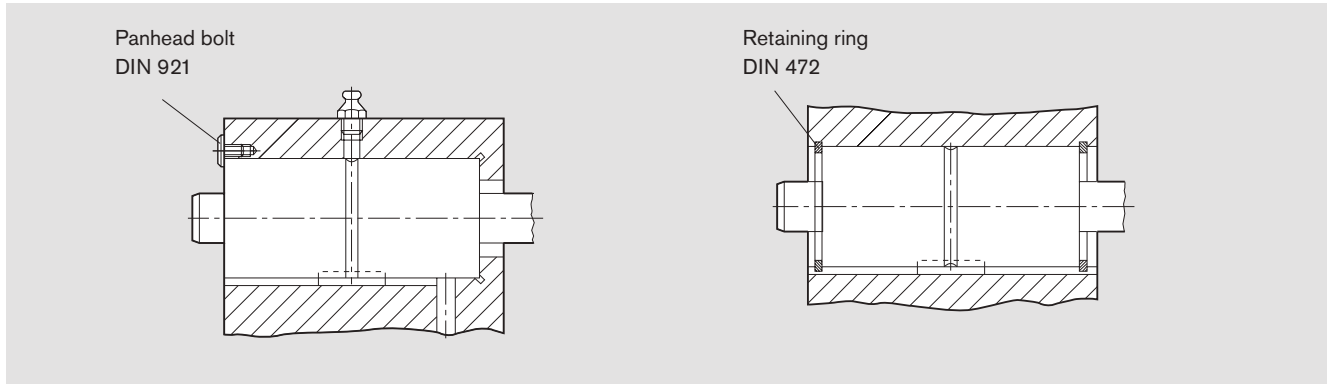

Shaft $\varnothing d$ (mm)	Ring nut Material number	Dimensions (mm)			Weight (g)
		D	D_1	B	
12	R1507 1 4003	M40x1.5	22	8	39.5
16	R1507 2 4004	M45x1.5	28	8	55.0
20	R1507 3 4005	M55x1.5	34	10	96.0
25	R1507 4 4006	M70x1.5	42	12	216.0
30	R1507 5 4007	M78x2	52	15	286.0
40	R1507 6 4009	M92x2	65	16	385.0
50	R1507 7 4011	M112x2	82	18	596.0

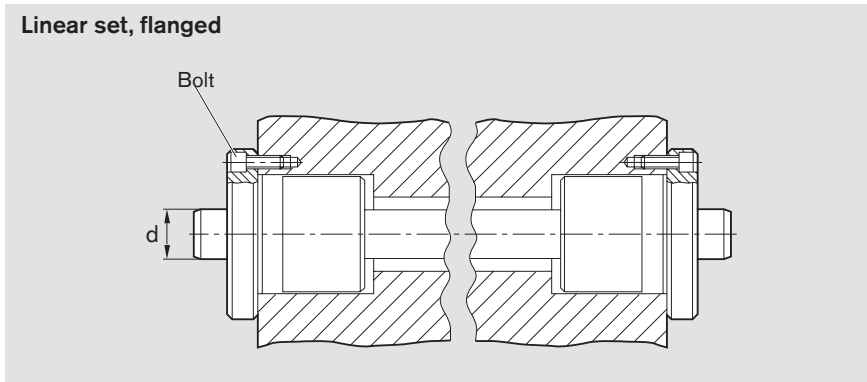

Shaft $\varnothing d$ (mm)	Bolt ISO 4762-8.8
12	M4x16
16	M4x16
20	M5x16
25	M6x20
30	M8x25
40	M8x25
50	M10x30

Lubrication

Initial lubrication

Torque-resistant linear bushings do not have an initial lubrication. Grease linear bushings before use, see "Initial lubrication" Section "Lubrication" on page 21. eLINE linear bushings come with initial lubrication.

Service life data is based on initial lubrication and relubricated linear bushings.

- Lubricating a linear set with a torque-resistant compact linear bushing:
on-shaft via $\varnothing = 3.9$ lubricating hole until lubricant comes out.
- Lubricating a tandem linear set:
on-shaft via recirculating lubricating groove in middle of outer diameter until lubricant comes out.
- Lubricating a flanged linear set:
on-shaft via funnel-type lube nipple recessed on the front side until lubricant comes out.



Linear sets with torque-resistant compact linear bushings

Linear sets, R0721

Design

- Compact steel sleeve
- Torque-resistant compact linear bushing
- Precision steel shaft with ball guide groove
- Torque-transmitting, hardened steel bearing plates come set to zero clearance
- Top wiper seals
- Stabilized version: see Linear sets, tandem
- Keyway for torque transmission
- Relubricatable

- One ball guide groove for diameter shafts 12 and 16 mm
- Two ball guide grooves for diameter shafts 20 mm and higher



Shaft Ø d (mm)	Material number for linear set with shaft		
	Standard length as per table	Shaft length cut to size ¹	Customized shaft
	LSHDR.- ... -WV- ...	LSHDR.- ... -WV-K	LSHDR.- ... -SPECIAL
12	R0721 212 80	R0721 212 89	R0721 212 86
16	R0721 216 80	R0721 216 89	R0721 216 86
20	R0721 520 80	R0721 520 89	R0721 520 86
25	R0721 525 80	R0721 525 89	R0721 525 86
30	R0721 530 80	R0721 530 89	R0721 530 86
40	R0721 540 80	R0721 540 89	R0721 540 86
50	R0721 550 80	R0721 550 89	R0721 550 86

- 85 Shaft length 900 mm
- 87 Shaft length 1,200 mm
- 88 Shaft length 2,000 mm

1) Also available with hollow shaft for shaft diameters 25 and higher: R0721 ... 69 or with ISO 683-17/EN 10088 stainless steel solid shaft: R0721 ... 79.

Explanation of sample short product name

LS	H	DR	2	20	WV	2000
Linear set	Compact linear bushing, sleeve design	Torque	Two ball guide grooves	Ø 20	Shaft included	2,000 mm

See page 159 for more information on short product names.

Dimensions

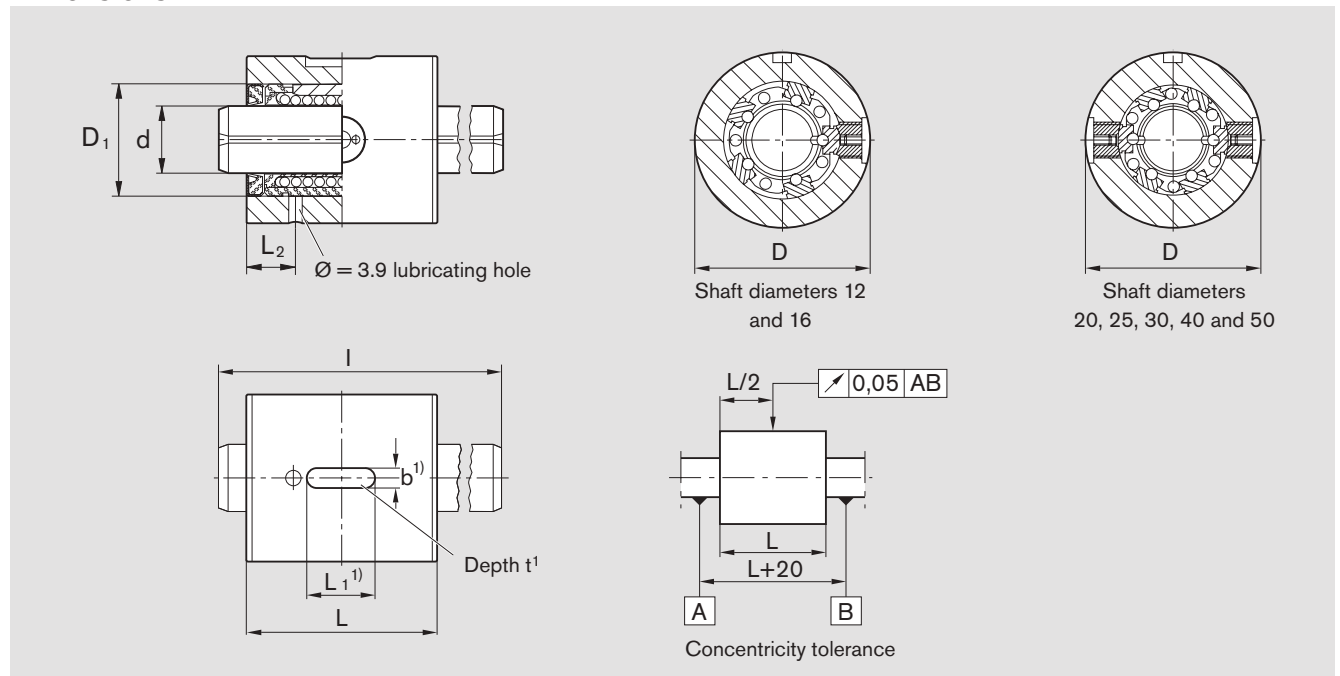

1) For fitting key A... DIN 6885.

Dimensions (mm)									Standard length (mm)	Torsional load moment M_t (Nm)	Load ratings ² (N)		Weight	
$\varnothing d$	D h6	L h11	D_1	L_1	b P9	t	L_2	dyn. C			stat. C_0	Linear set (kg)	Shaft (kg/m)	
12	32	40	22	14	5	3.0	11.0	400	2.0	640	420	0.16	0.89	
16	36	44	26	16	5	3.0	12.0	400	3.3	780	530	0.20	1.57	
20	48	55	32	20	5	3.0	14.0	500	12.0	1,550	1,050	0.50	2.45	
25	56	68	40	25	6	3.5	15.5	500	24.0	3,030	2,180	0.80	3.80	
30	65	80	47	28	6	3.5	16.5	600	37.0	3,680	2,790	1.20	5.50	
40	80	92	62	32	8	4.0	18.5	600	86.0	6,320	4,350	1.80	9.80	
50	100	114	75	40	8	4.0	22.5	600	167.0	9,250	6,470	3.70	15.30	

2) The load ratings indicated are minimal values as the load direction cannot always be clearly defined.

The dynamic load ratings are based on a total travel of 100,000 m.
When based on 50,000 m, the C values in the table are multiplied by 1.26.



Linear sets with torque-resistant compact linear bushings

Tandem

Linear sets, R0722

Design

- Compact steel sleeve
 - Two torque-resistant compact linear bushings
 - Precision steel shaft with ball guide groove
 - Torque-transmitting, hardened steel bearing plates come set to zero clearance
 - Top wiper seals
 - Stabilized version
 - Keyway for torque transmission
 - Relubricatable
- One ball guide groove for diameter shafts 12 and 16 mm
 - Two ball guide grooves for diameter shafts 20 mm and higher



Shaft Ø d (mm)	Material number for linear set with shaft		
	Standard length as per table	Shaft length cut to size ¹	Customized shaft
	LSHDR.T- ... -WV- ...	LSHDR.T- ... -WV-K	LSHDR.T- ... -SPECIAL
12	R0722 212 80	R0722 212 89	R0722 212 86
16	R0722 216 80	R0722 216 89	R0722 216 86
20	R0722 520 80	R0722 520 89	R0722 520 86
25	R0722 525 80	R0722 525 89	R0722 525 86
30	R0722 530 80	R0722 530 89	R0722 530 86
40	R0722 540 80	R0722 540 89	R0722 540 86
50	R0722 550 80	R0722 550 89	R0722 550 86

- 85 Shaft length 900 mm
- 87 Shaft length 1,200 mm
- 88 Shaft length 2,000 mm

1) Also available with hollow shaft for shaft diameters 25 and higher: R0722 ... 69 or with ISO 683-17/EN 10088 stainless steel solid shaft: R0722 ... 79.

Explanation of sample short product name

LS	H	DR	2	T	20	WV	2000
Linear set	Compact linear bushing, sleeve design	Torque	Two ball guide grooves	Tandem	Ø 20	Shaft included	2,000 mm

See page 159 for more information on short product names.

Dimensions

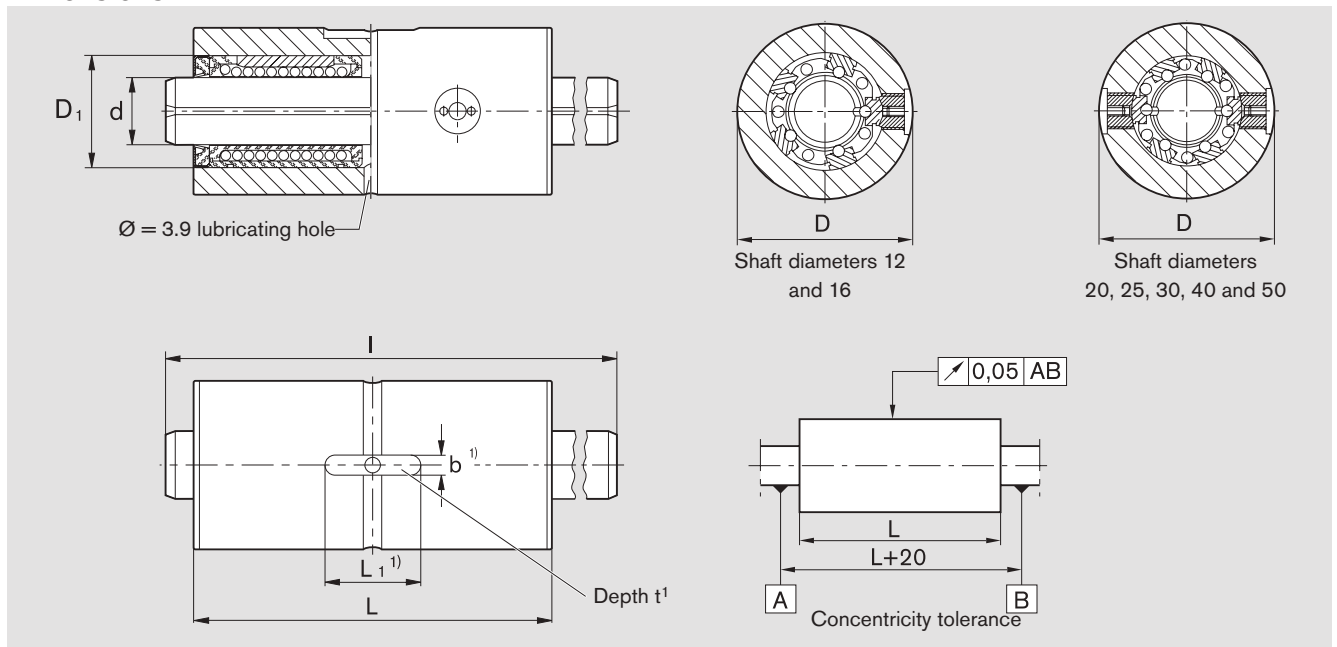

1) For fitting key A... DIN 6885.

Dimensions (mm)								Standard length l (mm)	Torsional load moment M_t (Nm)	Load ratings ² (N)		Weight	
$\varnothing d$	D h6	L h11	D_1	L_1	b P9	t	dyn. C			stat. C_0	Linear set (kg)	Shaft (kg/m)	
12	32	76	22	20	5	3.0	400	3.2	1,040	840	0.32	0.89	
16	36	84	26	22	5	3.0	400	5.5	1,260	1,060	0.40	1.57	
20	48	104	32	28	5	3.0	500	20.0	2,500	2,100	0.95	2.45	
25	56	130	40	36	6	3.5	500	40.0	4,900	4,360	1.50	3.80	
30	65	152	47	40	6	3.5	600	60.0	6,000	5,580	2.30	5.50	
40	80	176	62	45	8	4.0	600	140.0	10,200	8,700	3.50	9.80	
50	100	224	75	63	8	4.0	600	272.0	15,000	12,940	7.30	15.30	

2) Load rating when both linear bushings are under equal load.

The load ratings indicated are minimal values as the load direction cannot always be clearly defined.

The dynamic load ratings are based on a total travel of 100,000 m.

When based on 50,000 m, the C values in the table are multiplied by 1.26.



Linear sets with torque-resistant compact linear bushings

Flanged

Linear sets, R0723

Design

- Steel flanged sleeve
- Torque-resistant compact linear bushing
- Precision steel shaft with ball guide groove
- Torque-transmitting, hardened steel bearing plates come set to zero clearance
- Top wiper seals
- Stabilized version:
For installing two linear sets, see section "Installing linear sets with torque-resistant linear bushings"
- Relubricatable

- One ball guide groove for diameter shafts 12 and 16 mm
- Two ball guide grooves for diameter shafts 20 mm and higher



Shaft Ø d (mm)	Material number for linear set with shaft		
	Standard length as per table	Shaft length cut to size ¹	Customized shaft
	LSFDR.- ... -WV- ...	LSFDR.- ... -WV-K	LSFDR.- ... -SPECIAL
12	R0723 212 80	R0723 212 89	R0723 212 86
16	R0723 216 80	R0723 216 89	R0723 216 86
20	R0723 520 80	R0723 520 89	R0723 520 86
25	R0723 525 80	R0723 525 89	R0723 525 86
30	R0723 530 80	R0723 530 89	R0723 530 86
40	R0723 540 80	R0723 540 89	R0723 540 86
50	R0723 550 80	R0723 550 89	R0723 550 86

- 85 Shaft length 900 mm
- 87 Shaft length 1,200 mm
- 88 Shaft length 2,000 mm

1) Also available with hollow shaft for shaft diameters 25 and higher: R0723 ... 69 or with ISO 683-17/EN 10088 stainless steel solid shaft: R0723 ... 79.

Explanation of sample short product name

LS	F	DR	2	20	WV	2000
Linear set	Compact linear bushing, flanged	Torque	Two ball guide grooves	Ø 20	Shaft included	2,000 mm

See page 159 for more information on short product names.

Dimensions

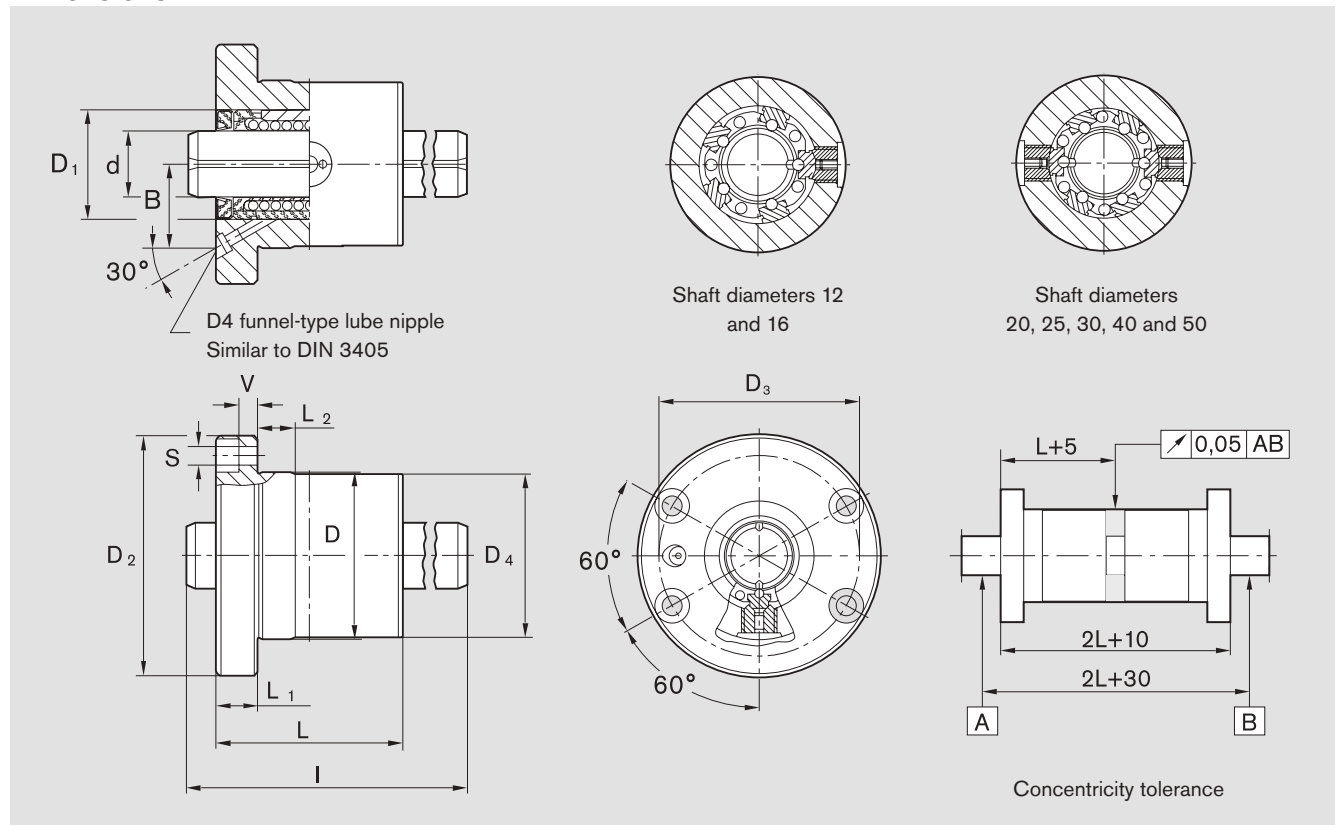

Dimensions (mm)													Standard length I (mm)	Torsional load moment M_t (Nm)	Load ratings ² (N)		Weight	
$\varnothing d$	D h6	D ₄ -0.1 -0.3	D ₁	D ₂	L h11	L ₁ -0.2	L ₂	D ₃	S ¹	V	B	dyn. C			stat. C ₀	Linear set (kg)	Shaft (kg/m)	
12	32	32	22	50	40	10	10	40	4.5	4.5	17.4	400	2.0	640	420	0.25	0.89	
16	36	36	26	54	44	10	10	44	4.5	4.5	20.0	400	3.3	780	530	0.30	1.57	
20	48	48	32	70	55	12	10	58	5.5	5.0	24.0	500	12.0	1,550	1,050	0.70	2.45	
25	56	56	40	82	68	14	10	68	6.6	5.5	29.0	500	24.0	3,030	2,180	1.10	3.80	
30	65	65	47	98	80	18	10	80	9.0	7.0	33.0	600	37.0	3,680	2,790	1.75	5.50	
40	80	80	62	114	92	18	16	95	9.0	7.0	41.7	600	86.0	6,320	4,350	2.50	9.80	
50	100	100	75	140	114	22	16	118	11.0	8.5	50.5	600	167.0	9,250	6,470	4.85	15.30	

1) ISO 4762-8.8 fastening bolts.

2) The load ratings indicated are minimal values as the load direction cannot always be clearly defined.

The dynamic load ratings are based on a total travel of 100,000 m.
When based on 50,000 m, the C values in the table are multiplied by 1.26.



Torque-resistant linear bushings with four ball guide grooves

Torque-resistant linear bushing, R0724 2 Four ball guide grooves

Design

- Hardened and machined outer sleeve
- POM ball retainer

- Balls made of rolling bearing steel
- **Integrated wiper seals**
- Fitting key for torque transmission
- Relubricatable



Size	Material number KBDR4-H- ... -DD	Weight (kg)
4	R0724 204 00	0.0065
6	R0724 206 00	0.0190
8	R0724 208 00	0.0230
10	R0724 210 00	0.0540
13	R0724 213 00	0.0700
16	R0724 216 00	0.1500
20	R0724 220 00	0.2000
25	R0724 225 00	0.2200
30	R0724 230 00	0.3500
40	R0724 240 00	0.8100
50	R0724 250 00	1.5000

Explanation of sample short product name

KB	DR	4	H	20	DD
Linear bushing	Torque	4 ball guide grooves	Cylindrical, sleeve design	Size 20	Integrated wiper seals

See page 158 for more information on short product names.

Precision steel shafts, R0724 0 Four ball guide grooves

For torque-resistant linear bushings R0724; R0725, flanged; R0726, miniature flanged; R0727, rotary flanged

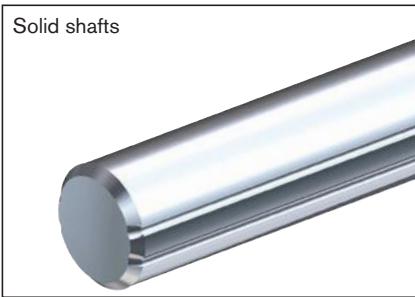

Size	Material number for solid shafts			Weight (kg/m)
	WVDR4- ... - ... Shaft length l _{max.}	WVDR4- ... -K Shaft length To specification	WVDR4- ... -SPECIAL Machined shaft To drawing	
4	R0724 004 02	R0724 004 89	R0724 004 86	0.10
6	R0724 006 02	R0724 006 89	R0724 006 86	0.21
8	R0724 008 02	R0724 008 89	R0724 008 86	0.38
10	R0724 010 02	R0724 010 89	R0724 010 86	0.60
13	R0724 013 02	R0724 013 89	R0724 013 86	1.00
16	R0724 016 02	R0724 016 89	R0724 016 86	1.50
20	R0724 020 02	R0724 020 89	R0724 020 86	2.00
25	R0724 025 02	R0724 025 89	R0724 025 86	3.10
30	R0724 030 02	R0724 030 89	R0724 030 86	4.80
40	R0724 040 02	R0724 040 89	R0724 040 86	8.60
50	R0724 050 02	R0724 050 89	R0724 050 86	13.10

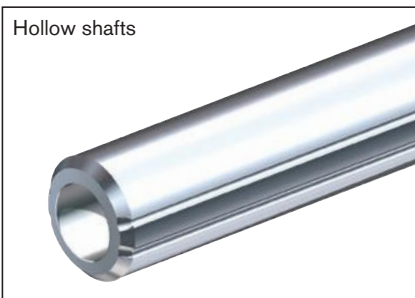

Size	Material number for hollow shafts			Weight (kg/m)
	WODR4- ... - ... Shaft length l _{max.}	WODR4- ... -K Shaft length To specification	WODR4- ... -SPECIAL Machined shaft To drawing	
4	R0724 004 32	R0724 004 69	R0724 004 66	0.082
6	R0724 006 32	R0724 006 69	R0724 006 66	0.195
8	R0724 008 32	R0724 008 69	R0724 008 66	0.340
10	R0724 010 32	R0724 010 69	R0724 010 66	0.510
13	R0724 013 32	R0724 013 69	R0724 013 66	0.800
16	R0724 016 32	R0724 016 69	R0724 016 66	1.200

Explanation of sample short product name

WV	DR	4	20	600
Solid shaft	Torque	4 ball guide grooves	Size 20	600 mm long

See page 161 for more information on short product names.

Dimensions of R0724 2

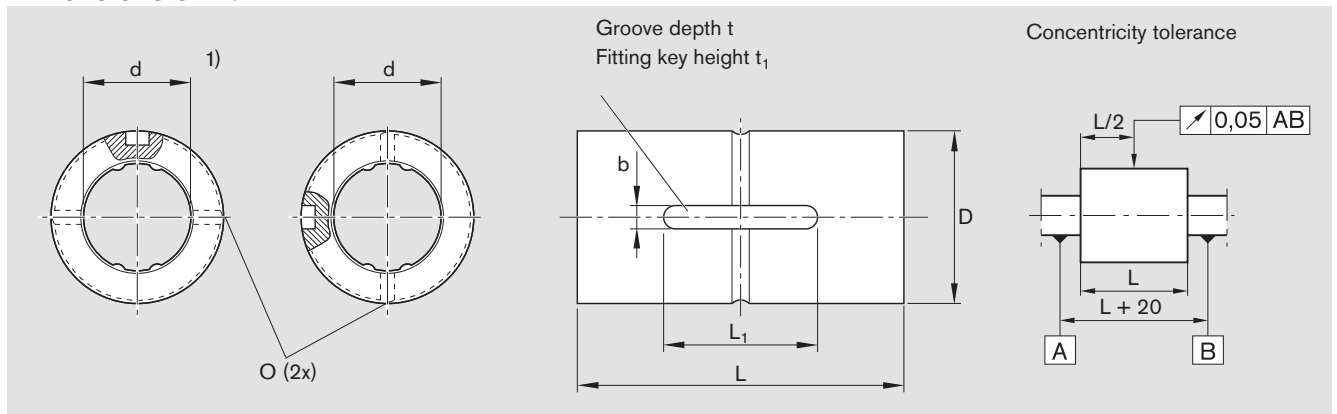

1) Sizes 4, 6, 8, 10

Size ²	Dimensions (mm)						Torsional load moment (Nm)		Load ratings ³⁾ (N)			
	Ø d	D h6	L	L ₁	O	t	t ₁	b	dyn. M _t	stat. M _{t0}	dyn. C	stat. C ₀
4	4.0	10	16 _{-0.2}	6.0	-	1.2	2.0	2.0	0.59	1.05	680	1,220
6	6.0	14	25 _{-0.2}	10.5	1.0	1.2	2.5	2.5	1.20	2.40	970	2,280
8	8.0	16	25 _{-0.2}	10.5	1.5	1.2	2.5	2.5	1.70	3.70	1,150	2,870
10	10.0	21	33 _{-0.2}	13.0	1.5	1.5	3.0	3.0	3.50	8.20	2,170	5,070
13	13.0	24	36 _{-0.2}	15.0	1.5	1.5	3.0	3.0	16.70	39.20	2,120	4,890
16	16.0	31	50 _{-0.2}	17.5	2.0	2.0	3.5	3.5	48.00	110.00	4,860	11,200
20	18.2	32	60 _{-0.2}	26.0	2.0	2.5	4.0	4.0	66.00	133.00	6,200	11,300
25	23.0	37	70 _{-0.3}	33.0	3.0	3.0	5.0	5.0	129.00	239.00	9,800	16,100
30	28.0	45	80 _{-0.3}	41.0	3.0	4.0	7.0	7.0	229.00	412.00	14,800	23,200
40	37.4	60	100 _{-0.3}	55.0	4.0	4.5	8.0	10.0	500.00	882.00	24,400	37,500
50	47.0	75	112 _{-0.3}	60.0	4.0	5.0	10.0	15.0	1,100.00	3,180.00	36,600	74,200

2) Shaft diameter varies

3) The load ratings indicated are minimal values as the load direction cannot always be clearly defined.

The dynamic load ratings are based on a total travel of 100,000 m.

When based on 50,000 m, the C values in the table are multiplied by 1.26.

Note on installation:

Recommended housing bore tolerance: H6 or H7.

Radial clearance: about ± 5 µm;

Align the tracks and wiper seals when inserting the shaft and make sure they are not skewed.

Dimensions of R0724 0

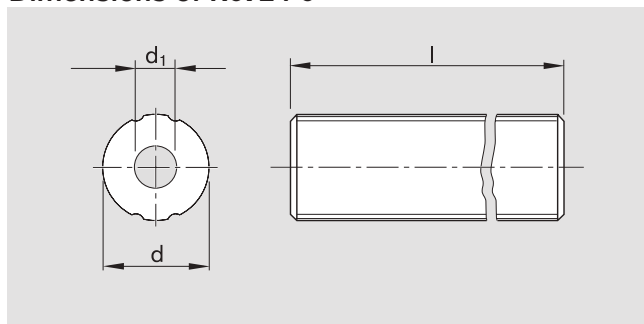

Size ¹	Dimensions (mm)		
	Ø d h7	d ₁	Shaft length l _{max}
4	4.0	1.5	300
6	6.0	2.0	600
8	8.0	3.0	600
10	10.0	4.0	600
13	13.0	6.0	600
16	16.0	8.0	600
20	18.2	-	1,500
25	23.0	-	1,500
30	28.0	-	1,500
40	37.4	-	1,800
50	47.0	-	1,800

1) Shaft diameter varies

Torque-resistant linear bushings with four ball guide grooves

Torque-resistant linear bushing, R0725 Flanged, with four ball guide grooves

Torque-resistant linear bushing, R0726 Miniature flanged, with four ball guide grooves

Design

- Hardened and machined outer sleeve
- POM ball retainer
- Balls made of rolling bearing steel
- **Integrated wiper seals**
- Relubricatable



Size	Material number KBDR4-F- ...DD	Weight (kg)
6	R0725 206 00	0.037
8	R0725 208 00	0.042
10	R0725 210 00	0.094
13	R0725 213 00	0.100
16	R0725 216 00	0.200
20	R0725 220 00	0.220
25	R0725 225 00	0.320
30	R0725 230 00	0.510
40	R0725 240 00	1.150
50	R0725 250 00	2.100



Size	Material number KBDR4-FM- ...DD	Weight (kg)
6	R0726 206 00	0.029
8	R0726 208 00	0.035
10	R0726 210 00	0.075

Note: See "Precision steel shafts, R0724 0 Four ball guide grooves" for matching shafts.

The dynamic load ratings are based on a total travel of 100,000 m.
When based on 50,000 m, the C values in the table are multiplied by 1.26.

Note on installation:

Recommended housing bore tolerance: H6 or H7.
Radial clearance: about $\pm 5 \mu\text{m}$.
Align the tracks and wiper seals when inserting the shaft and make sure they are not skewed.

Explanation of sample short product name

KB	DR	4	F	20	DD
Linear bushing	Torque	4 ball guide grooves	Flanged version	Size 20	Integrated wiper seals

See page 158 for more information on short product names.

Dimensions for R0725

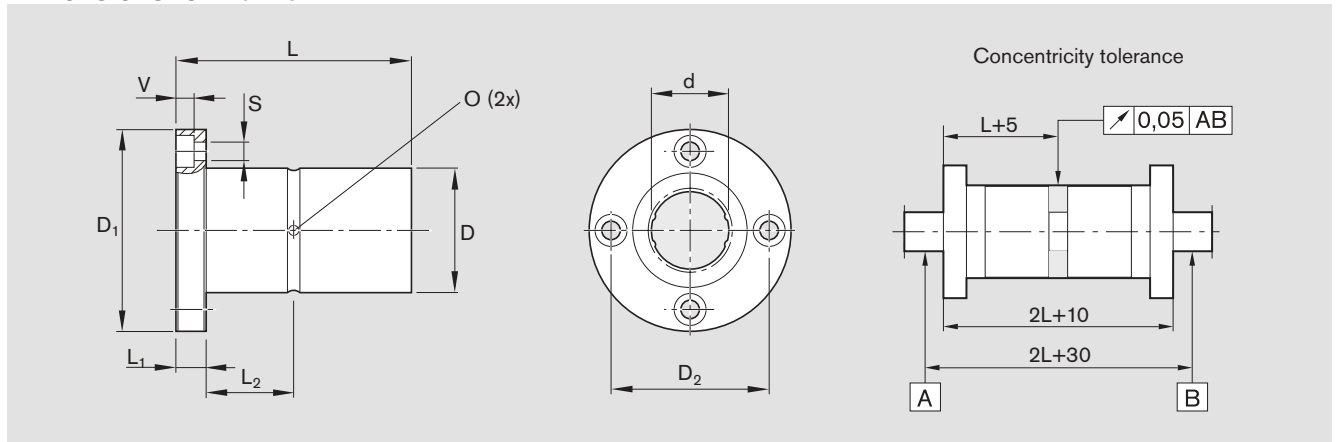

Size ¹	Dimensions (mm)										Torsional load moment (Nm)		Load ratings ² (N)	
	Ø d	D h6	D ₁	D ₂	L	L ₁	L ₂	V	S ³	O	dyn. M _t	stat. M _{t0}	dyn. C	stat. C ₀
6	6.0	14	30	22	25 _{-0.2}	5	7.5	3.3	3.4	1.0	1.2	2.4	970	2,280
8	8.0	16	32	24	25 _{-0.2}	5	7.5	3.3	3.4	1.5	1.7	3.7	1,150	2,870
10	10.0	21	42	32	33 _{-0.2}	6	10.5	4.4	4.5	1.5	3.5	8.2	2,170	5,070
13	13.0	24	43	33	36 _{-0.2}	7	11.0	4.4	4.5	1.5	16.7	39.2	2,120	4,890
16	16.0	31	50	40	50 _{-0.2}	7	18.0	4.4	4.5	2.0	48.0	110.0	4,860	11,200
20	18.2	32	51	40	60 _{-0.2}	7	23.0	4.4	4.5	2.0	66.0	133.0	6,200	11,300
25	23.0	37	60	47	70 _{-0.3}	9	26.0	5.4	5.5	3.0	129.0	239.0	9,800	16,100
30	28.0	45	70	54	80 _{-0.3}	10	30.0	6.5	6.6	3.0	229.0	412.0	14,800	23,200
40	37.4	60	90	72	100 _{-0.3}	14	36.0	8.6	9.0	4.0	500.0	882.0	24,400	37,500
50	47.0	75	113	91	112 _{-0.3}	16	40.0	11.0	11.0	4.0	1,100.0	3,180.0	36,600	74,200

Dimensions for R0726

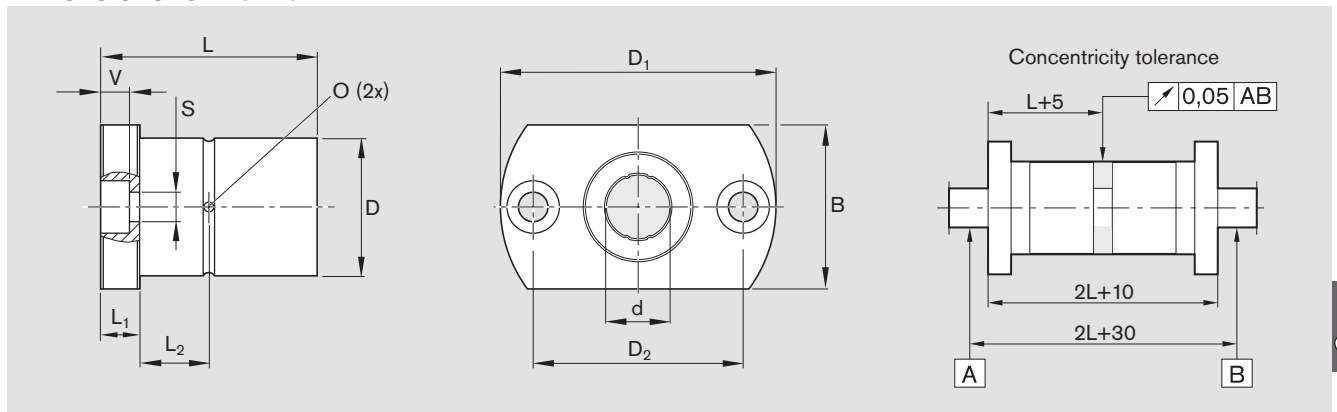

Size ¹	Dimensions (mm)											Torsional load moment (Nm)		Load ratings ² (N)	
	Ø d	D h6	D ₁	D ₂	B	L -0.2	L ₁	L ₂	V	S ³	O	dyn. M _t	stat. M _{t0}	dyn. C	stat. C ₀
6	6	14	30	22	18	25	5	7.5	3.3	3.4	1.0	1.2	2.4	970	2,280
8	8	16	32	24	21	25	5	7.5	3.3	3.4	1.5	1.7	3.7	1,150	2,870
10	10	21	42	32	25	33	6	10.5	4.4	4.5	1.5	3.5	8.2	2,170	5,070

1) Shaft diameter varies

2) The load ratings indicated are minimal values as the load direction cannot always be clearly defined.

3) ISO 4762-8.8 fastening bolts

Torque-resistant linear bushings with four ball guide grooves

Torque-resistant linear bushing, R0727 Rotary flanged, with four ball guide grooves

Design

- Hardened and machined outer sleeve
- POM ball retainer
- Balls made of rolling bearing steel
- **Integrated wiper seals**
- Integrated cross-roller bearing have had an initial lubrication



Size	Material number KBDR4-LR- ...DD	Weight (kg)
20	R0727 220 00	0.45
25	R0727 225 00	0.75
30	R0727 230 00	1.25
40	R0727 240 00	2.30

Note: See “Precision steel shafts, R0724 0 Four ball guide grooves” for matching shafts.

Explanation of sample short product name

KB	DR	4	LR	20	DD
Linear bushing	Torque	4 ball guide grooves	Rotary bearing	Size 20	Integrated wiper seals

See page 158 for more information on short product names.

Note on lubrication

The linear bushing must get an initial lubrication and be removed from the shaft for relubrication. The cross-roller bearing comes with an initial lubrication and can be relubricated via the lube port.

Dimensions

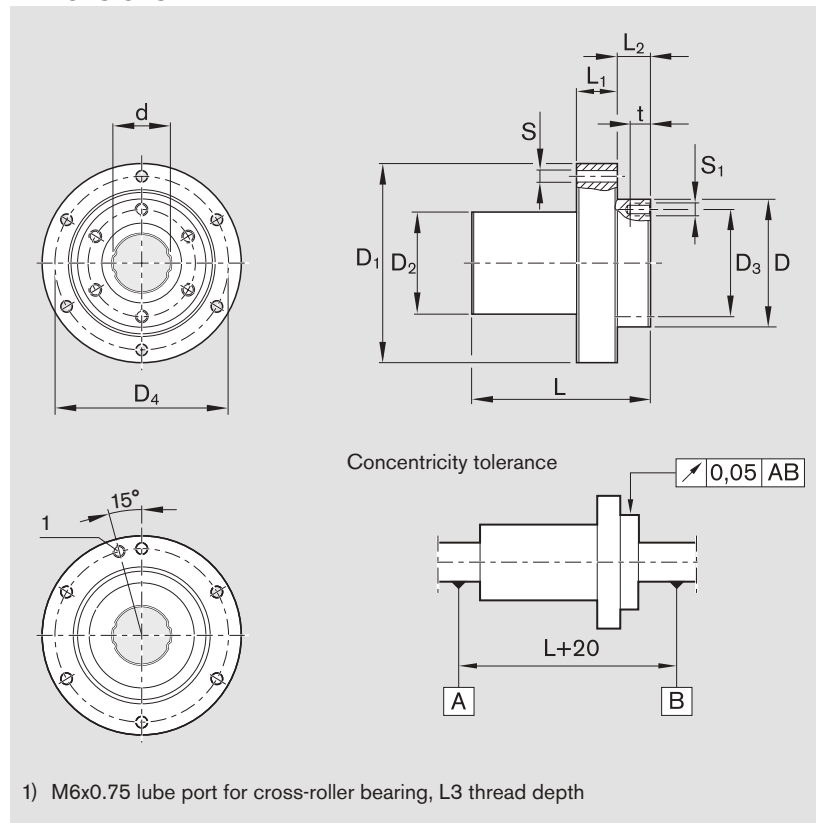

Recommended installation

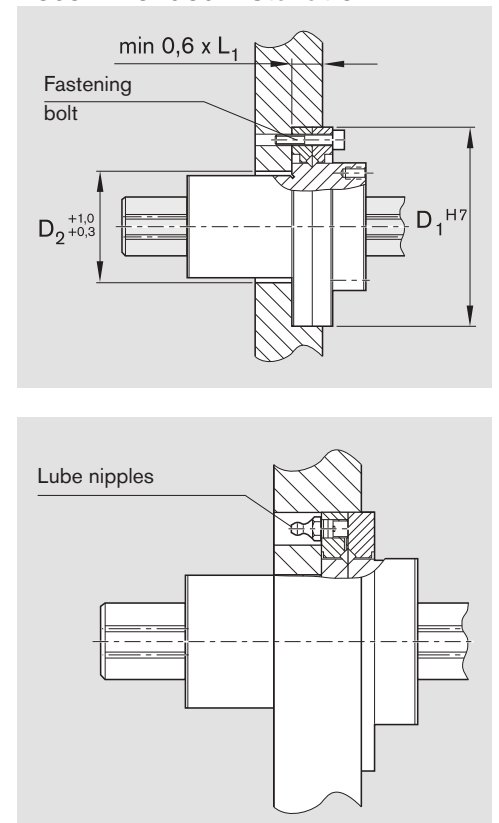

Size ²	Dimensions (mm)												
	Ø d	D h7	D ₁ h7	D ₂	D ₃	D ₄	L	L ₁	L ₂	L ₃	S	S ₁	t
20	18.2	40	66	34	34	56	60 _{-0.2}	13	12	5.2	4.5	M4	7
25	23.0	50	78	40	42	68	70 _{-0.3}	16	13	6.4	4.5	M5	8
30	28.0	61	100	47	52	86	80 _{-0.3}	17	17	6.8	6.6	M6	10
40	37.4	76	120	62	64	104	100 _{-0.3}	20	23	8.0	9.0	M6	10

Size ²	Torque-resistant linear bushing				Cross-roller bearing		Speed limit (rpm)	Tightening torque ⁴ Fastening bolt	
	Torsional load moment (Nm)		Load ratings ³ (N)		Load ratings (N)			(Nm)	
	dyn. M _t	stat. M _{to}	dyn. C	stat. C ₀	dyn. C	stat. C ₀		Fastening bolt	
20	66	133	6,200	11,300	5,900	7,350	1,200	M4	3.9
25	129	239	9,800	16,100	9,110	11,500	1,000	M4	3.9
30	229	412	14,800	23,200	13,200	18,000	800	M6	12.7
40	500	882	24,400	37,500	22,800	32,300	600	M8	29.4

2) Shaft diameter varies

3) The load ratings indicated are minimal values as the orientation and direction of load cannot always be clearly defined.

4) Tightening torque at friction factor 0.125

The dynamic load ratings are based on a total travel of 100,000 m.

When based on 50,000 m, the C values in the table are multiplied by 1.26.

Note on installation:

Radial clearance: about ± 5 µm

Align the tracks and wiper seals when inserting the shaft and make sure they are not skewed.

⚠ Do not loosen the flange connection (cross-roller bearing). Tighten the fastening bolts in phases until the table value is reached.

Linear bushings for combined linear and rotary motion

Product overview

The benefits

- Linear bushings with deep-groove ball bearing or needle bearing
- Precise guiding at high load rating
- High speed and low friction
- For linear applications with additional rotation
- For grip and swivel functions
- For winding applications

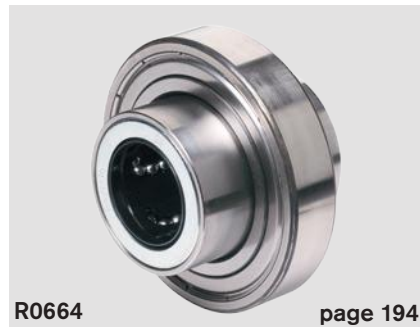

Explanation of short product name

Sample linear bushing:

Linear bushing for combined linear and rotary motion (rotation)
KBRON-30-DD

Definition of codes		KB	RO	N	30	DD
Type	Linear bushing	= KB				
Series	Combined linear and rotary motion (rotation)	= RO				
Form	Deep-groove ball bearing (series 618)	= R				
	Deep-groove ball bearing, shield (series 60)	= RD				
	Needle bearing	= N				
Shaft diameter		= 30				
Seals	With two seals	= DD				
	1 seal	= D				
	No seals	=				

Linear bushings for combined linear and rotary motion



Linear bushings for combined linear and rotary motion

**Linear bushings for combined linear and rotary motion, R0663
Series 618 deep-groove ball bearing**

**Linear bushings for combined linear and rotary motion, R0664
Series 60 deep-groove ball bearing**

Design

- Maintenance-free sealed shields (series 60, prelubricated)

Shaft diameters 12 to 40

- Segmental linear bushing
- Steel sleeve
- Top wiper seals
- Pressed-on deep-groove ball bearing

Shaft diameters 5, 8, 50, 60 and 80

- Standard linear bushing
- Integrated wiper seals
- Pressed-on deep-groove ball bearing



Shaft Ø d (mm)	Material number with series 618 deep-groove ball bearing KBROR-...-DD	Weight (kg)
5	R0663 205 00	0.02
8	R0663 208 00	0.06
12	R0663 212 00	0.08
16	R0663 216 00	0.11
20	R0663 220 00	0.15
25	R0663 225 00	0.17
30	R0663 230 00	0.35
40	R0663 240 00	0.49
50	R0663 250 00	1.29
60	R0663 260 00	2.39
80	R0663 280 00	5.35



Shaft Ø d (mm)	Material number with series 60 deep-groove ball bearing KBRORD-...-DD	Weight (kg)
5	R0664 205 00	0.03
8	R0664 208 00	0.11
12	R0664 212 00	0.14
16	R0664 216 00	0.20
20	R0664 220 00	0.27
25	R0664 225 00	0.32
30	R0664 230 00	0.56
40	R0664 240 00	0.87
50	R0664 250 00	1.78
60	R0664 260 00	3.26

Explanation of sample short product name

KB	RO	R	20	DD
Linear bushing	Combined linear and rotary motion (rotation)	Deep-groove ball bearing	Ø 20	With two seals

See page 192 for more information on short product names.

Dimensions

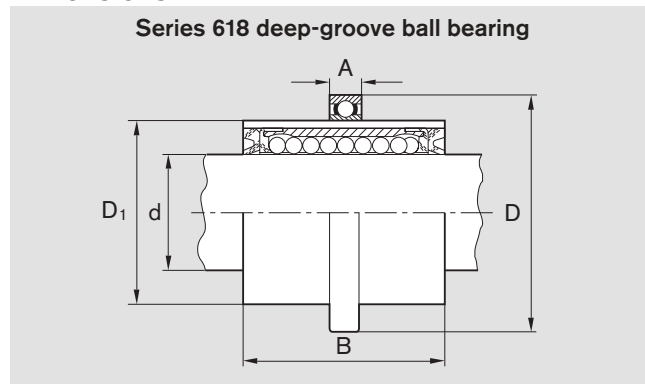

Dimensions (mm)					Load ratings ³⁾ (N)	
Ø d	D	D ₁	A	B	C	C ₀
5	21	12 ¹⁾	5	22	180	140
8 ²⁾	32	20	7	25	320	240
12	37	25	7	30	480	420
16	42	30	7	34	720	620
20	47	35	7	38	1,020	870
25	52	40	7	45	1,630	1,360
30	65	50	7	54	2,390	1,960
40	78	60	10	66	3,870	3,270
50	95	75 ¹⁾	10	100	8,260	6,470
60	115	90 ¹⁾	13	125	11,500	9,160
80	150	120 ¹⁾	16	165	21,000	16,300

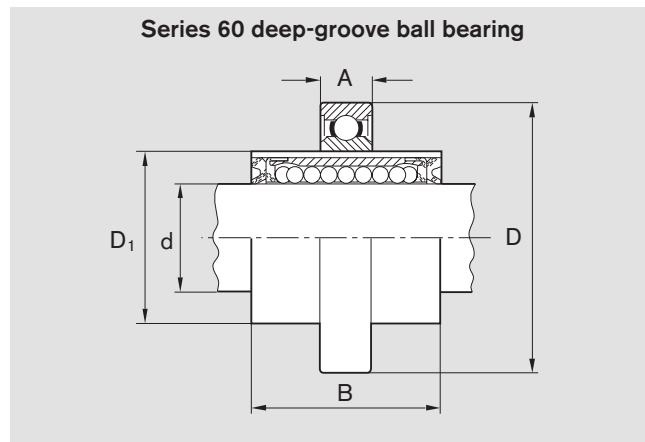

Dimensions (mm)					Load ratings ³⁾ (N)	
Ø d	D	D ₁	A	B	C	C ₀
5	28	12 ¹⁾	8	22	180	140
8 ²⁾	42	20	12	25	320	240
12	47	25	12	30	480	420
16	55	30	13	34	720	620
20	62	35	14	38	1,020	870
25	68	40	15	45	1,630	1,360
30	80	50	16	54	2,390	1,960
40	95	60	18	66	3,870	3,270
50	115	75 ¹⁾	20	100	8,260	6,470
60	140	90 ¹⁾	24	125	11,500	9,160

- 1) Oversized.
- 2) Spacer sleeve between bearing and standard linear bushing.
- 3) The load ratings indicated are minimal values as the orientation and load direction cannot be clearly defined.

The dynamic load ratings are based on a total travel of 100,000 m.
When based on 50,000 m, the C values in the table are multiplied by 1.26.

Seal:

The linear bushings are sealed on both sides.
Series R0663: Please request our table TB06-060-00 for sealing deep-groove ball bearing with shaft seal rings.
Series R0664: The deep-groove ball bearing are sealed on both sides with shields and are maintenance-free for all sizes.

Recommended installation tolerances

Series R0663 and R0664: Shaft: d_{h6}
Housing bore D^{K6} or D^{K7}

Another tolerance zone can be chosen in special instances (see Rolling element manufacturer's installation recommendations).



Operating temperatures

-10 °C to 80 °C

Initial lubrication

Linear bushings for combined linear and rotary motion do not have an initial lubrication. Grease linear bushings before use, see "Initial lubrication" Section "Lubrication" on page 21.
Service life data is based on initial lubrication and relubricated linear bushings.

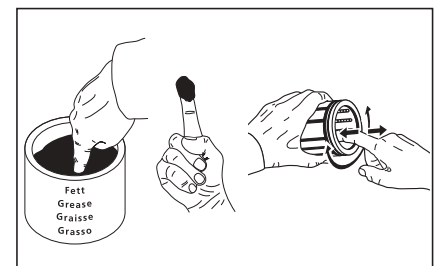

Linear bushings for combined linear and rotary motion

Linear bushings for combined linear and rotary motion, R0665 Needle bearing, no wiper seal

Linear bushings for combined linear and rotary motion, R0667 Needle bearing, no wiper seal

Design

- Standard linear bushing (closed)
- Needle bearing
- Steel intermediate rings
- Retaining rings



Shaft Ø d (mm)	Material number		Weight (kg)
	With two wiper seals KBRON-...-DD	No wiper seal KBRON- ...	
5	R0667 005 00	R0665 005 00	0.02
8	R0667 008 00	R0665 008 00	0.04
12	R0667 012 00	R0665 012 00	0.08
16	R0667 016 00	R0665 016 00	0.10
20	R0667 020 00	R0665 020 00	0.20
25	R0667 025 00	R0665 025 00	0.34
30	R0667 030 00	R0665 030 00	0.56
40	R0667 040 00	R0665 040 00	1.39
50	R0667 050 00	R0665 050 00	2.18
60	R0667 060 00	R0665 060 00	4.14
80	R0667 080 00	R0665 080 00	7.11

Explanation of sample short product name

KB	RO	N	20	DD
Linear bushing	Combined linear and rotary motion (rotation)	Needle bearing	Ø 20	With two seals

See page 192 for more information on short product names.

Dimensions

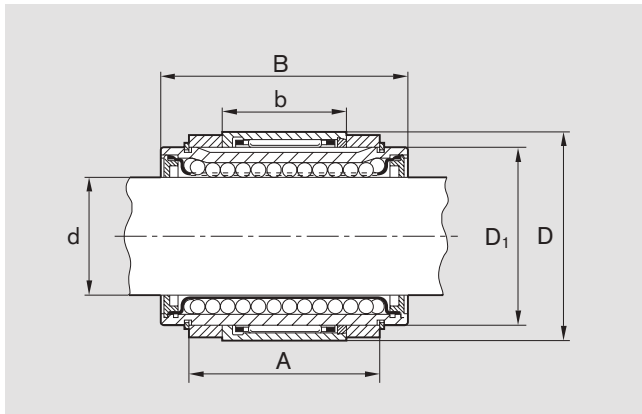

Recommended installation

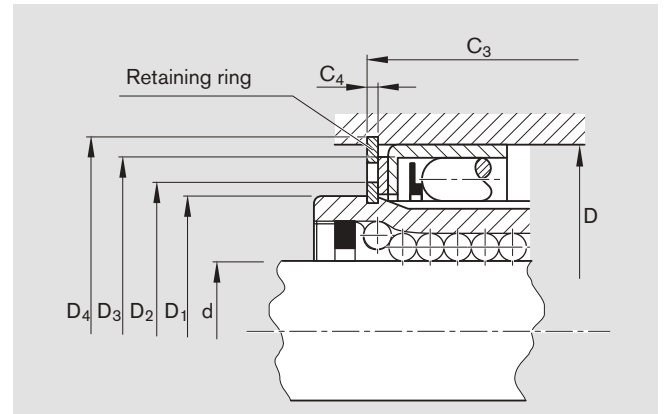

Dimensions (mm)											Retaining ring ³⁾		Load ratings ⁴⁾ (N)	
Ø d	D	D ₁	b	A	B	D ₂	D ₃	D ₄ H11	C ₃ H12	C ₄ H13		C	C ₀	
5	19	12.0	12.0	12.0	22	13.8	–	19.5	14.6	1.3	SB19	180	140	
8	24	16.0	13.0	14.1	25	19.3	23	24.8	16.5	1.3	SB24	320	240	
12	30	22.0	16.0	20.0	32	24.2	28	31.0	23.2	1.6	SB30	420	280	
16	34	26.0	20.0	22.1	36	28.4	32	35.0	25.3	1.6	SB34	580	440	
20	42	32.0	20.0	28.0	45	35.1	40	43.2	31.2	1.6	SB42	1,170	860	
25	50	40.0	30.0	40.0	58	43.1	48	51.2	43.2	1.6	SB50	2,080	1,560	
30	57	47.0	30.0	48.0	68	49.1	55	58.5	51.2	1.6	SB57	2,820	2,230	
40 ¹⁾	80	62.2 ²⁾	56.0	56.0	80	74.2	–	81.8	60.2	2.2	SB80	5,170	3,810	
50 ¹⁾	92	75.0	70.0	73.1	100	80.6	90	94.0	78.3	2.7	SB92	8,260	6,470	
60 ¹⁾	110	90.0	70.0	95.0	125	95.0	108	112.3	100.2	2.7	SB110	11,500	9,160	
80 ¹⁾	140	120.0	81.6	125.0	165	128.0	138	142.6	130.2	2.7	SB140	21,000	16,300	

- 1) Contrary to the figure, these sizes come with two needle bearings.
- 2) The body is a special version of the closed standard linear bushing.
- 3) Seeger-Orbis GmbH
- 4) The load ratings indicated are minimal values as the orientation and load direction cannot be clearly defined.

The dynamic load ratings are based on a total travel of 100,000 m.
 When based on 50,000 m, the C values in the table are multiplied by 1.26.

Recommended installation tolerances:

- Shaft d_{h6}
- Housing bore D^{K6} or D^{K7}
- Another tolerance zone can be chosen in special instances (see Rolling element manufacturer's installation recommendations).
- See recommended installation for axial securing of the needle bearing in the housing.
- Installing the needle bearing in the housing without additional axial securing is sufficient for numerous applications.
- Needle bearing with axial play on standard linear bushing

Operating temperatures

-10 °C to 80 °C

Initial lubrication

Linear bushings for combined linear and rotary motion do not have an initial lubrication. Grease linear bushings before use, see "Initial lubrication" Section "Lubrication" on page 21. Service life data is based on initial lubrication and relubricated linear bushings.

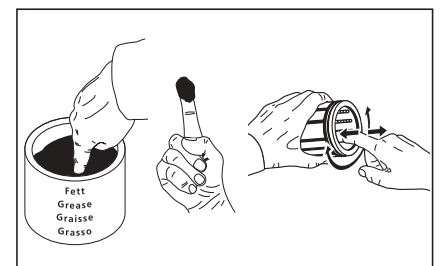

Precision steel shafts and shaft end machining

Product overview

The benefits

- Induction-hardened and polished
- Solid or hollow shafts
- Various tolerances
- Heat-treated, stainless or hard chrome-plated steel
- Cut to size
- Chamfered to protect linear bushing seals
- Fully machined to customer drawings
- Use as guide shafts for linear bushings
- Use as rollers, pistons and axes

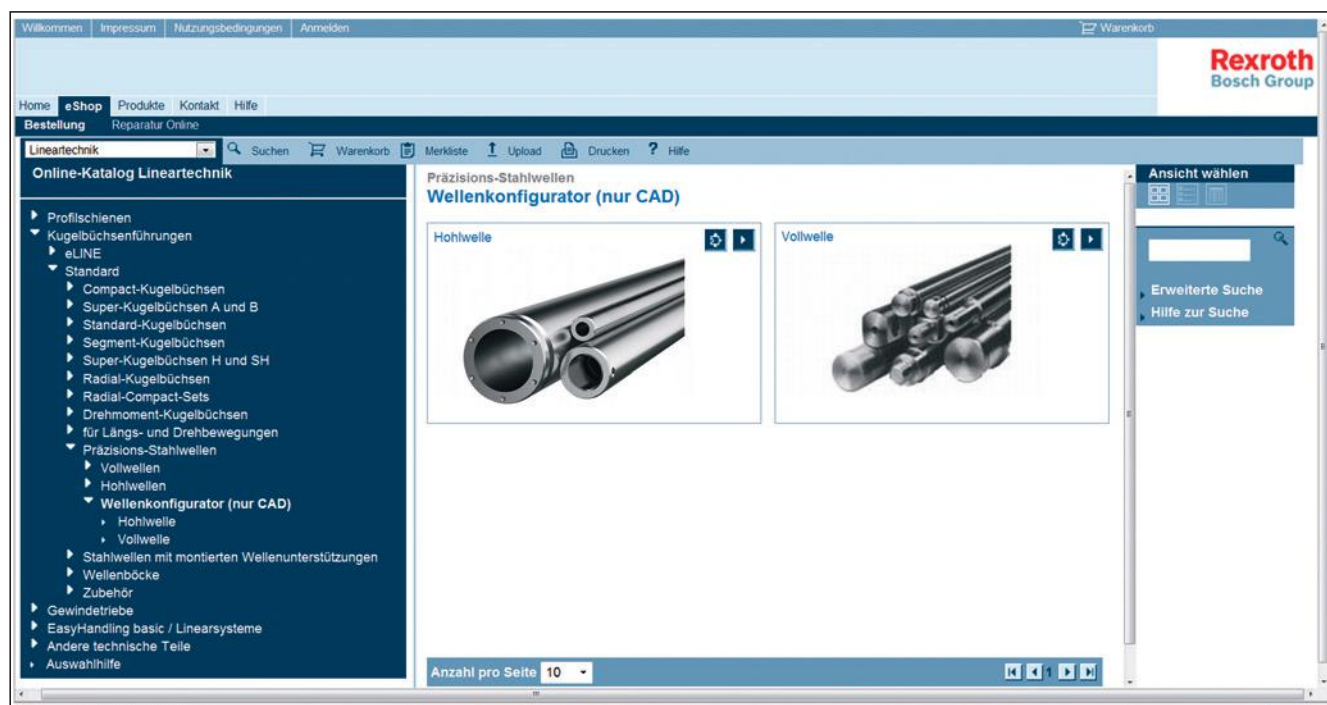

Use the shaft configuration tool to request machined shafts.
www.boschrexroth.com/shaft-configuration

Precision steel shafts and shaft end machining

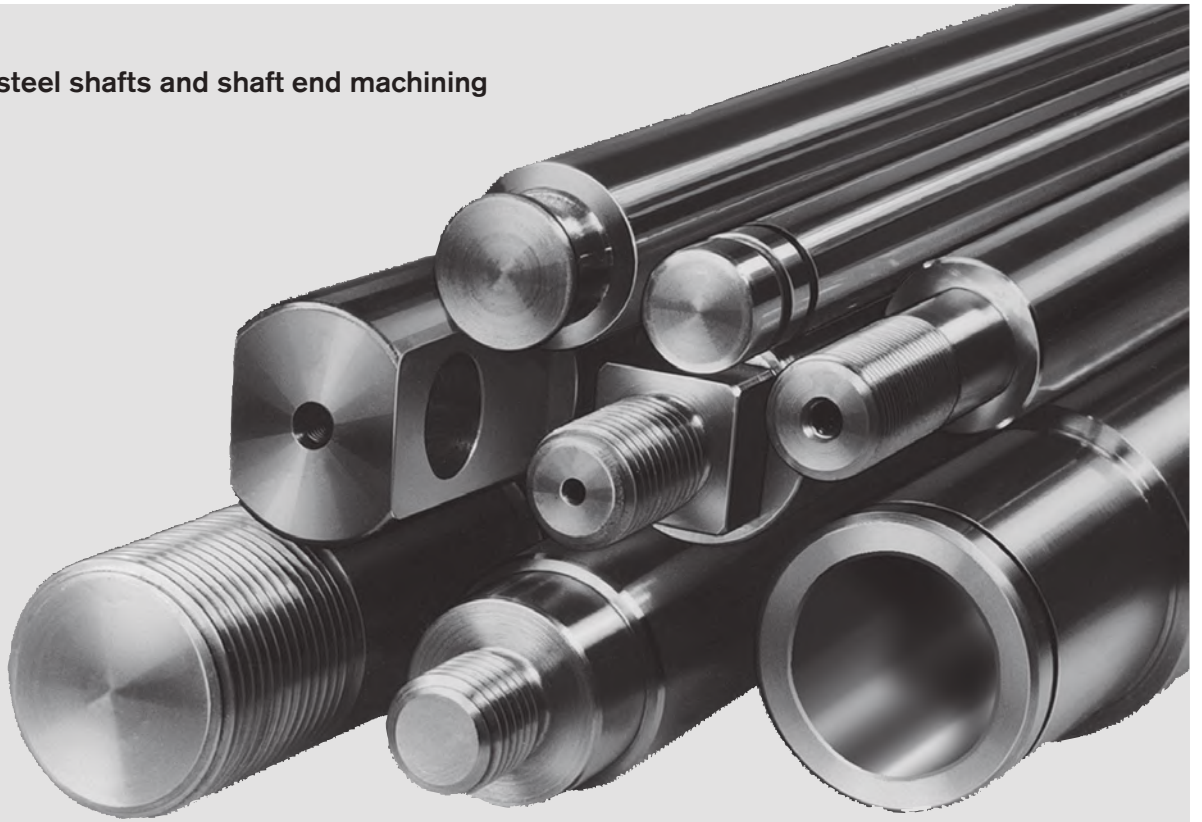

Precision steel shafts

Overview

Dimensions

Shaft Ø d (mm)	Part numbers for solid shafts		Max. usable Length (mm)	X46Cr13		Max. usable Length (mm)	X90CrMoV18		Max. usable Length (mm)
	Heat-treated Cf53 h6 ¹⁾	h7 ¹⁾		h6 ¹⁾	h7 ¹⁾		h6 ¹⁾	h7 ¹⁾	
3	R1000 003 00	–	400	–	–	–	R1000 003 20	–	400
4	–	–	–	R1000 004 30	R1000 004 31	3,450	–	–	–
5	R1000 005 00	R1000 005 01	5,650	R1000 005 30	R1000 005 31	3,450	–	–	–
6	R1000 006 00	R1000 006 01	5,650	R1000 006 30	R1000 006 31	3,450	–	–	–
8	R1000 008 00	R1000 008 01	5,900	R1000 008 30	R1000 008 31	5,900	–	–	–
10	R1000 010 00	R1000 010 01	5,900	R1000 010 30	R1000 010 31	3,450	–	–	–
12	R1000 012 00	R1000 012 01	5,900	R1000 012 30	R1000 012 31	5,900	R1000 012 20	R1000 012 21	5,900
14	R1000 014 00	R1000 014 01	5,900	R1000 014 30	R1000 014 31	5,900	–	–	–
15	R1000 015 00	R1000 015 01	5,900	–	–	–	–	–	–
16	R1000 016 00	R1000 016 01	5,900	R1000 016 30	R1000 016 31	5,900	R1000 016 20	R1000 016 21	5,900
18	R1000 018 00	R1000 018 01	5,900	–	–	–	–	–	–
20	R1000 020 00	R1000 020 01	5,900	R1000 020 30	R1000 020 31	5,900	R1000 020 20	R1000 020 21	5,900
22	R1000 022 00	R1000 022 01	5,900	–	–	–	–	–	–
24	R1000 024 00	R1000 024 01	5,900	–	–	–	–	–	–
25	R1000 025 00	R1000 025 01	5,900	R1000 025 30	R1000 025 31	5,900	R1000 025 20	R1000 025 21	5,900
30	R1000 030 00	R1000 030 01	5,900	R1000 030 30	R1000 030 31	5,900	R1000 030 20	R1000 030 21	5,900
32	R1000 032 00	R1000 032 01	5,900	–	–	–	–	–	–
35	R1000 035 00	R1000 035 01	5,900	–	–	–	–	–	–
38	R1000 038 00	R1000 038 01	5,900	–	–	–	–	–	–
40	R1000 040 00	R1000 040 01	5,900	R1000 040 30	R1000 040 31	5,900	R1000 040 20	R1000 040 21	5,900
45	R1000 045 00	R1000 045 01	5,900	–	–	–	–	–	–
50	R1000 050 00	R1000 050 01	5,900	R1000 050 30	R1000 050 31	5,900	R1000 050 20	R1000 050 21	5,900
55	R1000 055 00	R1000 055 01	5,900	–	–	–	–	–	–
60	R1000 060 00	R1000 060 01	5,900	R1000 060 30	R1000 060 31	5,900	R1000 060 20	R1000 060 21	5,900
70	R1000 070 00	R1000 070 01	5,900	–	–	–	–	–	–
80	R1000 080 00	R1000 080 01	5,900	R1000 080 30	R1000 080 31	5,900	R1000 080 20	R1000 080 21	5,900
100	R1000 100 00	R1000 100 01	5,900	–	–	–	–	–	–
110	R1000 110 00	R1000 110 01	5,900	–	–	–	–	–	–

1) Other tolerances upon request

Shaft Ø d (mm)	Part numbers for solid shafts Hard chrome-plated Cf53				Part numbers for hollow shafts Heat-treated C60; size Ø 8, Ø 10, Ø 16: 100Cr6				Hard chrome-plated Cf53	
	h6	Max. usable Length (mm)	h7	Max. usable Length (mm)	h6	h7	Max. usable Length	h7	Max. usable Length	
3	-	-	-	-	-	-	-	-	-	
4	-	-	-	-	-	-	-	-	-	
5	-	-	-	-	-	-	-	-	-	
6	-	-	-	-	-	-	-	-	-	
8	-	-	-	-	R1001 008 10	-	1,000	-	-	
10	-	-	-	-	R1001 010 10	-	1,000	-	-	
12	R1000 012 60	5,350	R1000 012 61	5,350	R1001 012 10	R1001 012 11	5,900	-	-	
14	R1000 014 60	5,350	R1000 014 61	5,350	-	-	-	-	-	
15	-	-	-	-	-	-	-	-	-	
16	R1000 016 60	6,350	R1000 016 61	6,350	R1001 016 10	R1001 016 11	2,000	-	-	
18	-	-	-	-	-	-	-	-	-	
20	R1000 020 60	6,450	R1000 020 61	6,450	R1001 020 10	R1001 020 11	5,900	-	-	
22	-	-	-	-	-	-	-	-	-	
24	-	-	-	-	-	-	-	-	-	
25	R1000 025 60	6,850	R1000 025 61	6,850	R1001 025 10	R1001 025 11	5,900	R1001 025 41	5,900	
30	R1000 030 60	6,850	R1000 030 61	6,850	R1001 030 10	R1001 030 11	5,900	R1001 030 41	5,900	
32	-	-	-	-	-	-	-	-	-	
35	-	-	-	-	-	-	-	-	-	
38	-	-	-	-	-	-	-	-	-	
40	R1000 040 60	6,850	R1000 040 61	6,850	R1001 040 10	R1001 040 11	5,900	R1001 040 41	5,900	
45	-	-	-	-	-	-	-	-	-	
50	R1000 050 60	6,850	R1000 050 61	6,850	R1001 050 10	R1001 050 11	5,900	R1001 050 41	5,900	
55	-	-	-	-	-	-	-	-	-	
60	R1000 060 60	6,850	R1000 060 61	6,850	R1001 060 10	R1001 060 11	5,900	R1001 060 41	5,900	
70	-	-	-	-	-	-	-	-	-	
80	R1000 080 60	6,850	R1000 080 61	6,850	R1001 080 10	R1001 080 11	5,900	R1001 080 41	5,900	
100	-	-	-	-	-	-	-	-	-	
110	-	-	-	-	-	-	-	-	-	



Precision steel shafts

Ordering information

Heat-treated solid steel shafts

As part of a linear guide, the role of the shaft places strict requirements on the materials used.

We offer the ideal shaft material for any diameter range.

Extremely consistent surface hardness and hardness depth combine with outstanding purity, consistent structure and balanced grading for extraordinarily long service life under rolling loads.

Available diameters (mm)	Ø d (mm)	Lengths (m)
3, 5, 6, 8, 10, 12, 14, 15, 16, 18, 20, 22,	3	0.4
24, 25, 30, 32, 35, 38, 40, 45, 50, 55, 60,	5 and 6	5.8
70, 80, 100, 110	8 and higher	6.1

Solid shafts with shaft diameters 20 mm to 8 m in length available upon request.

Sections combine for longer overall lengths.

Linear bushings roll over seams with ease.

Materials	Hardness
Cf53	Min. 60 HRC

Material number	
h6 tolerance	R1000 xxx 00
h7 tolerance	R1000 xxx 01

xxx = diameter in mm

Ordering example

Solid shaft, Ø = 25, h7, heat-treated steel, 460 mm long

Material number:
R1000 025 01, 460 mm

ISO 683-17/EN 10088 stainless steel solid shafts

The right choice for applications where corrosion resistance and cleanliness are critical, e.g., in the food industry, semiconductor production and medical equipment. X 90 CrMoV 18 is more resistant to lactic acid than X 46 Cr 13.

Materials	Available diameters (mm)
X 46 Cr 13	4, 5, 6, 8, 10, 12, 14, 16, 20, 25, 30, 40, 50, 60, 80
X 90 CrMoV 18	3, 12, 16, 20, 25, 30, 40, 50, 60, 80

Ø d (mm)	Lengths (m)
3	0.4
4 – 10	3.6
12 – 80	6.1

Sections combine for longer overall lengths.

Linear bushings roll over seams with ease.

Materials	Hardness
X 46 Cr 13	Min. 54 HRC
X 90 CrMoV 18	Min. 55 HRC

Material number for X 46 Cr 13	
h6 tolerance	R1000 0xx 30
h7 tolerance	R1000 0xx 31

Material number for X 90 CrMoV 18	
h6 tolerance	R1000 0xx 20
h7 tolerance	R1000 0xx 21

xx = diameter in mm

Ordering example:

Solid shaft, Ø = 16, h6, stainless steel X 46 Cr 13, 350 mm long

Material number:
R1000 016 30, 350 mm

Materials

	Code	Material no.
Heat-treated steel Solid shaft	Cf53	1.1213
	C60	1.0601
ISO 683-17/EN 10088 stainless steel	X 46 Cr 13	1.4034
	X 90 CrMoV 18	1.4112

Solid shafts, hard chrome-plated

Optimal shaft surface corrosion protection on outer diameter.

Available diameters (mm)	
12, 14, 16, 20, 25, 30, 40, 50, 60, 80	

Ø d (mm)	Lengths (m)
12, 14	5.35
16	6.35
20 – 80	6.85

Sections combine for longer overall lengths. Linear bushings roll over seams with ease.

Materials	Hardness
Cf53, C60	Min. 60 HRC (about 700 HV)
Chrome plating (about 10 µm thick)	About 1,000 HV

Material number	
h6 tolerance	R1000 0xx 60
h7 tolerance	R1000 0xx 61

xx = diameter in mm

Ordering example:
Solid shaft, Ø = 30, h7, hard chrome-plated, 480 mm long
Material number:
R1000 030 61, 480 mm

Heat-treated hollow steel shafts

Hollow shafts allow for electrical wiring, or liquid or gaseous media. Hollow shafts are also often used to save weight. The material is seamlessly rolled. The inner diameters are unmachined.

Available diameters (mm)		
Outer	Inner (approx.)	
8		3.0
10		4.0
12		4.0
16		8.0
20		14.0
25		14.0
30		19.0
40		26.5
50		29.6
60		36.5
80		57.4

Ø d (mm)	Max. lengths (m)
8, 10	1.0
16	2.0
12 and 20 – 80	6.1

Materials	Hardness
C60	Min. 60 HRC

Material number	
h6 tolerance	R1001 xxx 10
h7 tolerance	R1001 xxx 11

xxx = outer diameter in mm

Ordering example:
Hollow shaft, Ø = 80, h7, 3,600 mm long
Material number:
R1001 080 11, 3600 mm

Hollow shafts, hard chrome-plated

Hollow shafts are hard chrome-plated on the outer diameter. Max. length: 6.1 m

Available diameters (mm)		
Outer	Inner (approx.)	
25		14.0
30		19.0
40		26.5
50		29.6
60		36.5
80		57.4

Materials	Hardness
C60	Min. 60 HRC (about 700 HV)
Chrome plating About 10 µm thick	About 1,000 HV

Material number	
h7 tolerance	R1001 0xx 41

xx = outer diameter in mm

Ordering example:
Hollow shaft, Ø = 40, h7, hard chrome-plated, 2000 mm long
Material number:
R1001 040 41, 2000 mm

Precision steel shafts

Technical data

Dimensional accuracy and tolerance zones

The diameters of the precision steel shafts come in h6 and h7 tolerance zones. The adjacent table shows information on dimensional accuracy. The diameter tolerance of annealed shaft cross-sections vary slightly from the specified tolerance zone.

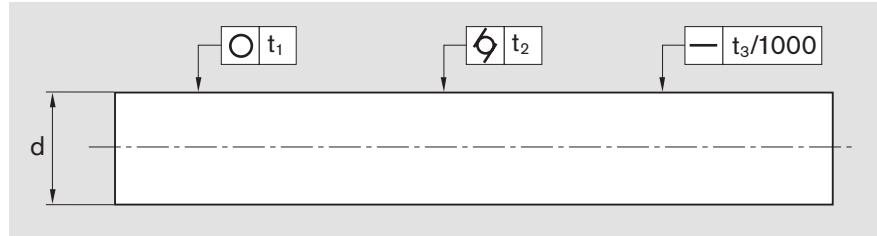

Nominal size ranges d (mm)	Over Up to	1	3	6	10	18	30	50	80
		3	6	10	18	30	50	80	120
Diameter tolerance (μm)	h6	0	0	0	0	0	0	0	0
		-6	-8	-9	-11	-13	-16	-19	-22
	h7	0	0	0	0	0	0	0	0
Roundness tolerance t ₁ (μm)	h6	3	4	4	5	6	7	8	10
	h7	4	5	6	8	9	11	13	15
Cylindricity t ₂ ¹⁾ (μm)	h6	4	5	6	8	9	11	13	15
	h7	6	8	9	11	13	16	19	22
Straightness t ₃ ²⁾ (μm/m)		150	150	120	100	100	100	100	100
Surface roughness (Ra) (μm)		0.32	0.32	0.32	0.32	0.32	0.32	0.32	0.32

1) Differences in diameter

2) The smallest possible value is 40 μm for lengths under 1 m. Straightness is measured based on ISO 13012.

Straightness based on ISO 13012

The measuring points are evenly distributed between the support points and the shaft sections protruding past them. More supports are used accordingly for long, thin shafts. Straightness is half of the gauge measurement when turning the shaft 360°.

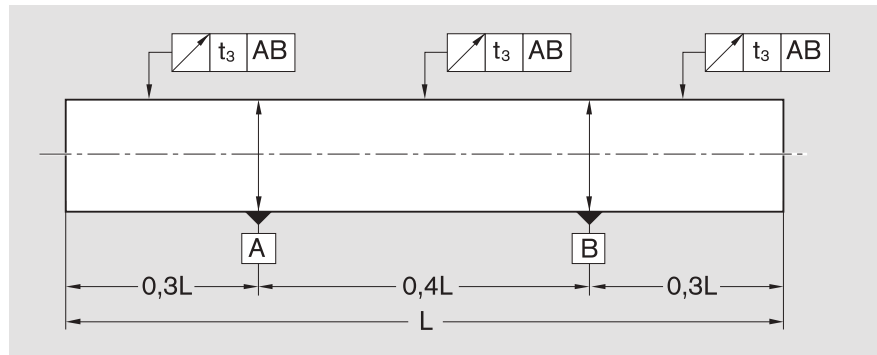

Roundness

The drawing shows the roundness of a raw shaft compared to a precision steel shaft.

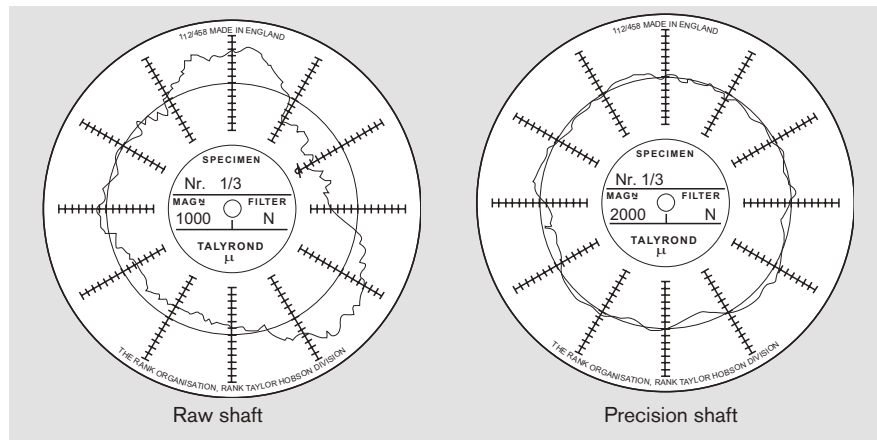

Shaft hardness

The outer zone of the shaft is induction-hardened. Depending on the shaft diameter, the depth of hardness ranges from 0.4 to 2.4 mm. Linear and transverse surface hardness and depth of hardness are highly consistent. This ensures high dimensional consistency and long service life.

The adjacent figure shows the cross-section and longitudinal section of a hardened and polished precision steel shaft. The hardened surface zone is made visible by caustic etching.

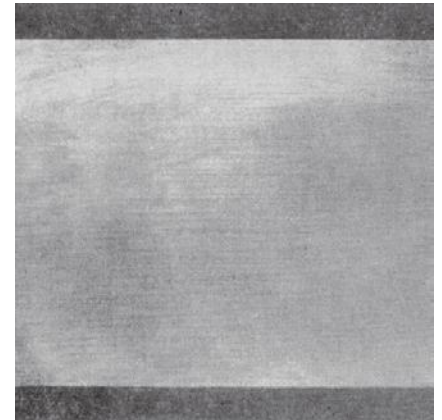
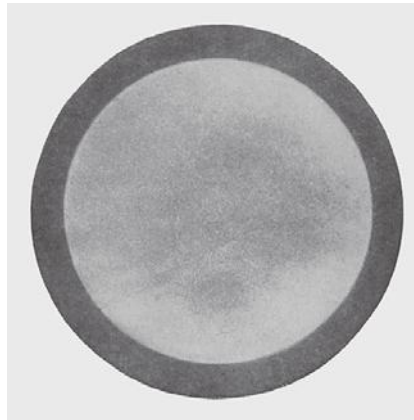

Shaft Ø d (mm)	Over To	1	3	10	18	30	50	80
		3	10	18	30	50	80	120
Depth of hardness (mm)	Min.	0.4	0.4	0.6	0.9	1.5	2.2	2.4

Min. surface hardness

Materials	Hardness
Cf53, C60	HRC 60
X 46 Cr13	HRC 54
X 90 CrMoV 18	HRC 55



Precision steel shafts

Technical data

Mill-cut lengths

Shaft design	Diameter (m)	Mill-cut length (m)	Ends not true to size ¹⁾
			Length (mm) (one side)
Solid shafts ²⁾	3	0.4	
	5, 6	5.8	75
	8 and higher	6.1	75
Hollow shafts	8, 10	1.0	
	16	2.0	
	12, 20 and higher	6.1	75
Stainless steel solid shafts	3	0.4	
	4 to 10	3.6	75
	12 and higher	6.1	75

1) Regarding geometry and hardness

2) Solid shafts with shaft diameters 20 mm to 8 m in length available upon request.

Interconnecting shafts

We also provide interconnectable steel shafts when more than the mill-cut length is needed. One shaft then comes with a spigot, the next with a matching recess (see figure). The interconnected shaft must be supported throughout or at intervals, though generally at the seas (see Section "Shaft support rails").

The shafts must be under axial tension when fastening the shaft support rails so no gaps form at the seams. Linear bushings roll over seams with ease.

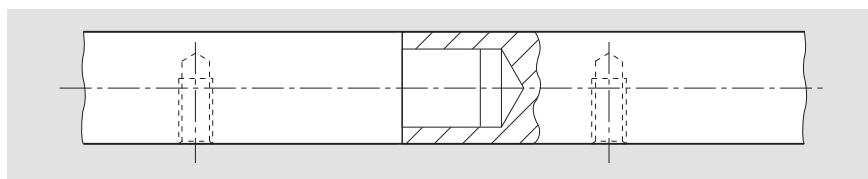

Chamfering

When used as round guides for linear bushings, the ends of steel shafts must be chamfered so the ball retainers/wiper seals are not damaged when the linear bushings are pressed onto the shafts. The figure and table show the chamfering dimensions.

Linear bushings with wiper seals cannot be pressed over sharp edges on the shaft (e.g., retaining ring grooves) since the sealing lips will be damaged.

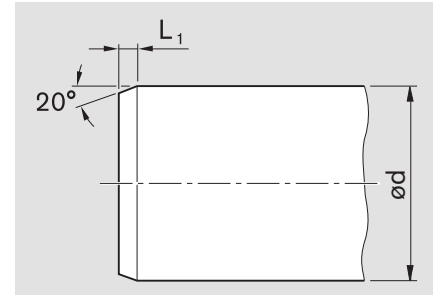

Shaft Ø d (mm)	3	4	5	8	10	12	14	16	20	25	30	40	50	60	80
Length of chamfers L ₁ (mm)	1	1	1.5	1.5	1.5	2	2	2	2	2	2	3	3	3	3

Machining

Hardened and polished steel shafts are available in mill-cut lengths. These can be cut to size and machined to include:

- Spigots
- Female and male threads
- Counterbores
- Radial and axial holes
- Grooves
- Other machining

Unmachined, cut-to-size shafts come chamfered for accident prevention when not otherwise ordered.

Annealing machined sections

Annealing may be necessary when machining shafts due to the hardened outer zone (minor change in size possible).

Length tolerance for cut-to-size shafts

Dimensions (mm)	Tolerance
Length up to 400	±0.5
over 400	±0.8
up to 1,000	
over 1,000	±1.2
up to 2,000	
over 2,000	±2.0
up to 4,000	
over 4,000	±3.0
up to 6,000	
over 6,000	±3.5
up to 8,000	

Steel shafts with smaller length tolerances are also available at additional cost.

Concentric and axial spigot runout

A review in accordance with a specified principle will be performed upon request. Values xxx < 0.02 upon request.

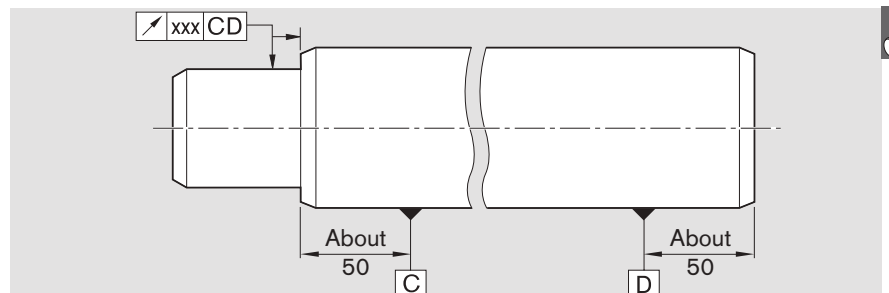

Precision steel shafts

Technical data

Shaft deflection

When steel shafts are used as guides for linear bushings, any shaft deflection that occurs due to load must remain within certain tolerances. Otherwise function and service life will be impacted.¹⁾

In order to make it easier to calculate warping, we have listed the most frequent load conditions with their corresponding deflection equations.

The equations for calculating any shaft inclination in the linear bushing ($\tan \alpha$) can also be found in this table.

Case no.	Load condition	Deflection equation	Shaft inclination in linear bushing
1		$f_1 = \frac{F \times a^3}{6 \times E \times I} \times \left(2 - \frac{3 \times a}{L} \right)$ $f_{m1} = \frac{F \times a^2}{24 \times E \times I} \times (3 \times L - 4a)$	$\tan \alpha_{(x=a)} = \frac{F \times a^2 \times b}{2 \times E \times I \times L}$
2		$f_2 = \frac{F \times L \times a^2}{2 \times E \times I} \times \left(1 - \frac{4}{3} \times \frac{a}{L} \right)$ $f_{m2} = \frac{F \times L^2 \times a}{8 \times E \times I} \times \left(1 - \frac{4}{3} \times \frac{a^2}{L^2} \right)$	$\tan \alpha_{(x=a)} = \frac{F \times a \times b}{2 \times E \times I}$
3		$f_3 = \frac{F \times a^3 \times b^3}{3 \times E \times I \times L^3}$ $f_{m3} = \frac{2 \times F \times a^3 \times b^2}{3 \times E \times I \times L^2} \times \left(\frac{L}{L + 2 \times a} \right)^2$	$\tan \alpha_{(x=b)} = \frac{F \times a^2 \times b^2}{2 \times E \times I \times L^2} \times \left(1 - \frac{2 \times b}{L} \right)$
4		$f_4 = \frac{F \times a^2 \times b^2}{3 \times E \times I \times L}$ $f_{m4} = f_4 \times \frac{L + b}{3 \times b} \times \sqrt{\frac{L + b}{3 \times a}}$	$\tan \alpha_{(x=b)} = \frac{F \times a}{6 \times E \times I \times L} \times (3 \times b^2 - L^2 + a^2)$
5		$f_{m5} = \frac{5 \times F \times L^3}{384 \times E \times I}$	$\tan \alpha_{(x=0)} = \frac{F \times L^2}{24 \times E \times I}$

1) Super linear bushings and experience no reduction in load rating or service life at a shaft inclination of up to 30' ($\tan 30' = 0.0087$).

- F = Load (N)
- a = Distance (mm)
- b = Distance (mm)
- L = Shaft length (mm)
- E = Young's modulus (N/mm²)
- I = Planar moment of inertia (mm⁴)
- f₁ to f₄ = Deflection at point of force application (mm)
- f_{m1} to f_{m5} = Max. deflection (mm)
- α = Shaft inclination in the linear bushing (°)

The table includes the values for the maximum acceptable shaft inclination ($\tan \alpha_{\max}$) when using standard linear bushings.

When $\tan \alpha = \tan \alpha_{\max}$, the acceptable static load is about $0.4 C_0$.

Shaft $\varnothing d$ (mm)	$\tan \alpha$	α (10^{-3}°)	α ($^\circ$)	α	
				(min.)	(sec)
5	12.3	70.5	0.0705	4	14
8	10.0	57.3	0.0573	3	26
12	10.1	57.9	0.0579	3	28
16	8.5	48.7	0.0487	2	55
20	8.5	48.7	0.0487	2	55
25	7.2	41.3	0.0413	2	29
30	6.4	36.7	0.0367	2	12
40	7.3	41.8	0.0418	2	30
50	6.3	36.1	0.0361	2	10
60	5.7	32.7	0.0327	1	58
80	5.7	32.7	0.0327	1	58

E x I values and weights for steel shafts

Solid shafts		
$\varnothing d$ (mm)	E x I (N x mm ²)	Weight (kg/m)
3	8.35×10^5	0.06
4	2.64×10^6	0.10
5	6.44×10^6	0.15
8	4.22×10^7	0.39
10	1.03×10^8	0.61
12	2.14×10^8	0.88
14	3.96×10^8	1.20
16	6.76×10^8	1.57
20	1.65×10^9	2.45
25	4.03×10^9	3.83
30	8.35×10^9	5.51
40	2.64×10^{10}	9.80
50	6.44×10^{10}	15.32
60	1.34×10^{11}	22.05
80	4.22×10^{11}	39.21

Hollow shafts			
Shaft diameter		E x I (N x mm ²)	Weight (kg/m)
Outer (mm)	Inner (mm)		
8	3.0	4.14×10^7	0.34
10	4.0	1.00×10^8	0.51
12	4.0	2.11×10^8	0.79
16	8.0	6.33×10^8	1.18
20	14.0	1.25×10^9	1.25
25	14.0	3.63×10^9	2.63
30	19.0	7.01×10^9	3.30
40	26.5	2.13×10^{10}	5.50
50	29.6	5.65×10^{10}	9.95
60	36.5	1.15×10^{11}	13.89
80	57.4	3.10×10^{11}	19.02

Calculation values:

Young's modulus = 2.1×10^5 N/mm²

Density = 7.8 g/cm³



Precision steel shafts

Shaft configuration tool

Shaft configuration tool in the Rexroth eShop

Rexroth offers an online product configuration tool for directly submitting product requests. Go to www.boschrexroth.com/shaft-configuration to quickly and easily configure specific solutions.

This online tool helps you visually configure your desired shaft machining step by step. All catalog options are available.

Once configuration is complete, 2D and 3D data is available for download in all established formats.

Please send us a consulting request through the online tool for prices and delivery times.

The figures only show a small portion of our diverse machining options. Rexroth will machine shaft ends to suit your needs. Just send us your request!

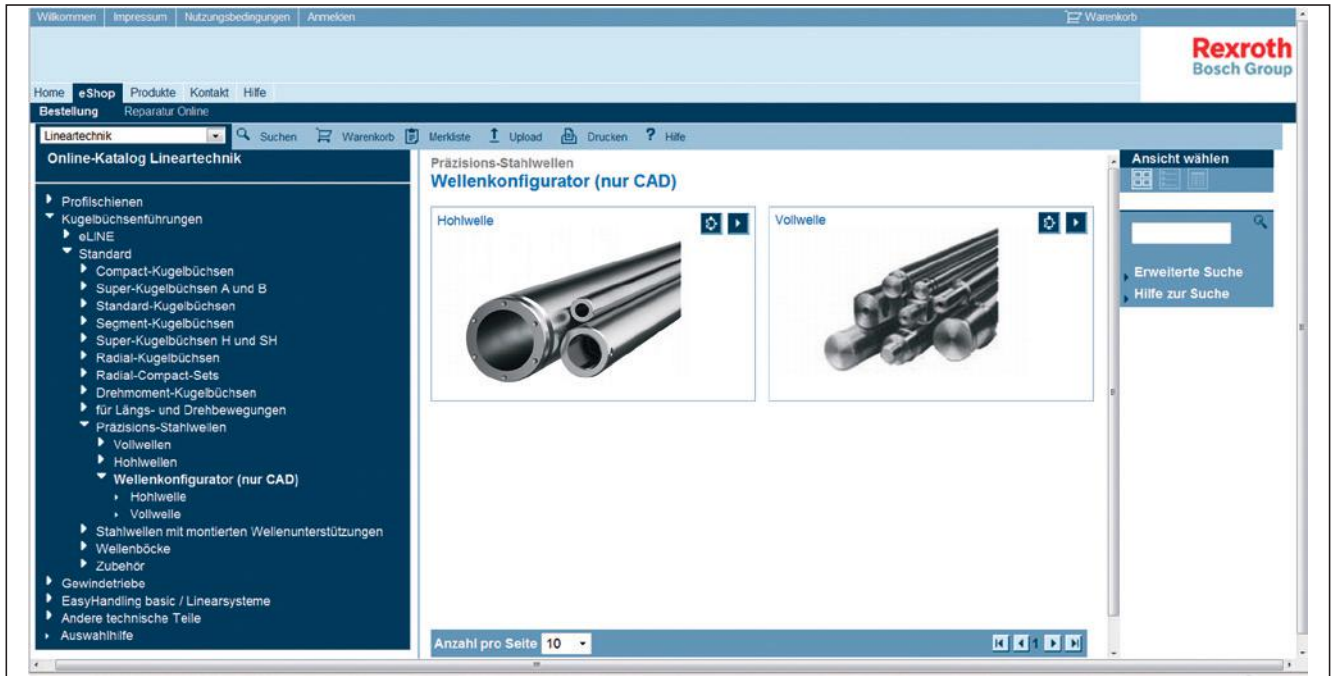

Go to the "Shaft configuration tool" submenu in the eShop.

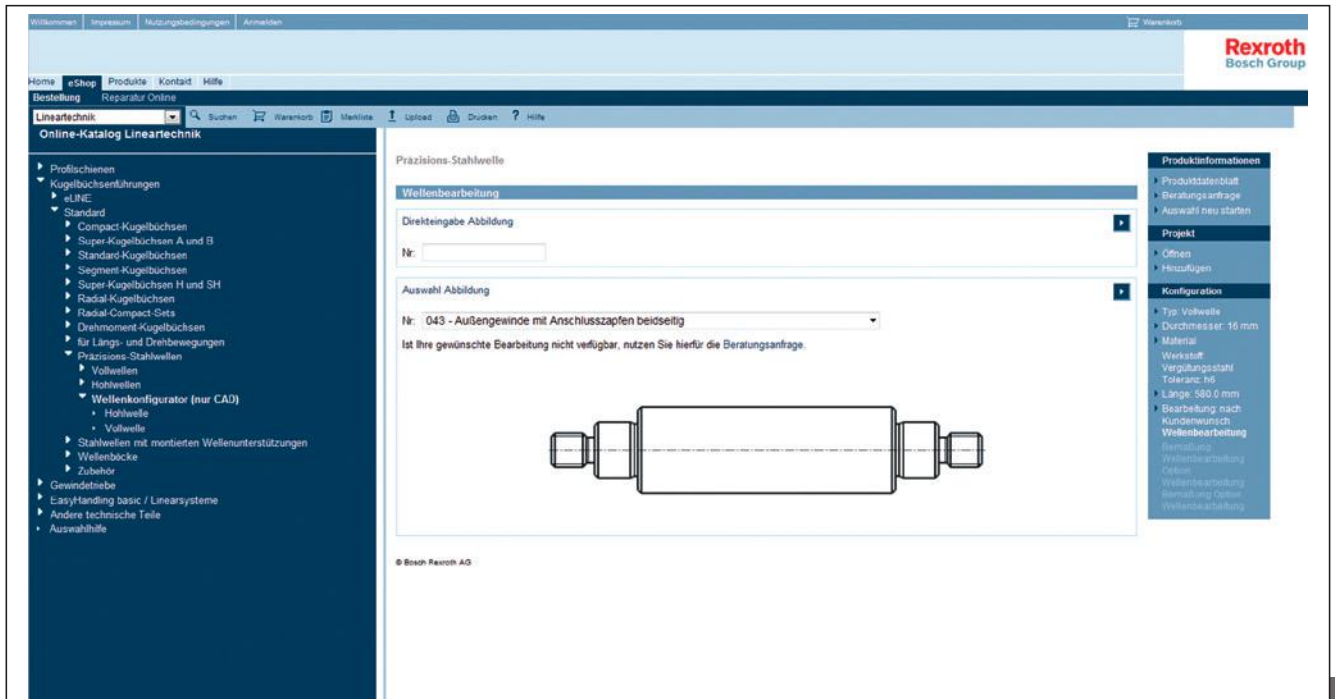

If you have the catalog, you can immediately enter the machining image number under the menu item "Machining to customer specification - Quick start".





If you do not have the catalog, you can choose from all possible shaft machining options step by step under the menu item "Machining to customer specification".

Precision steel shafts

Standard shaft machining

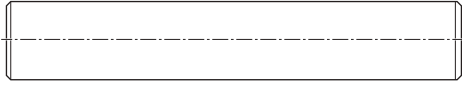
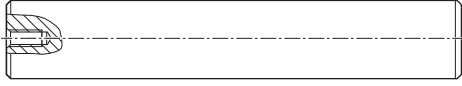

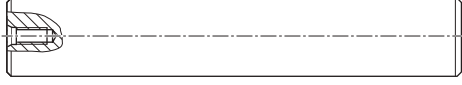
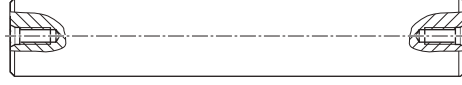
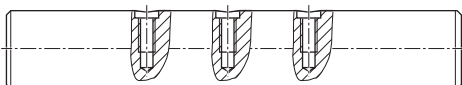
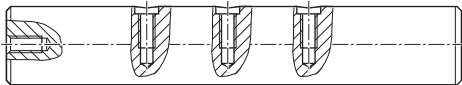
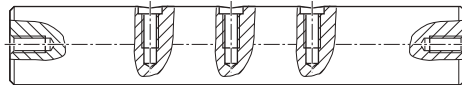
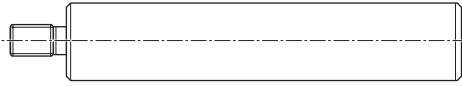
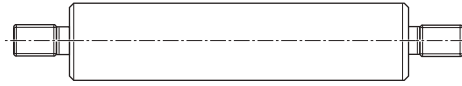
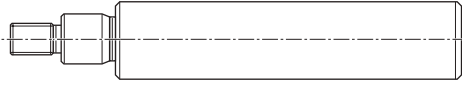
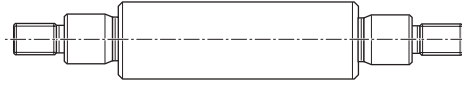
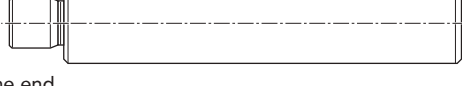
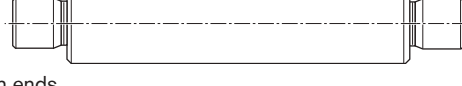
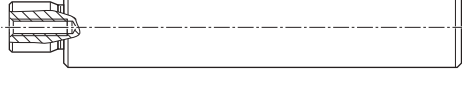
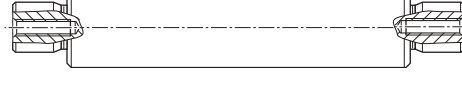

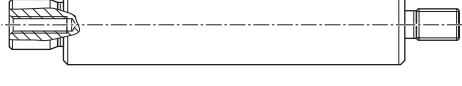
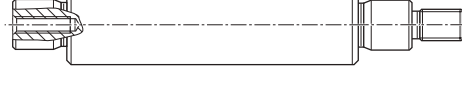



Solid shafts

Machining by image number

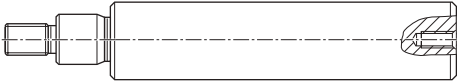
<p>010</p>  <p>Planar and rotated to length tolerance</p>	
<p>020</p>  <p>Female thread on one end</p>	<p>021</p>  <p>Female thread on both ends</p>
<p>022</p>  <p>DIN 332-D female thread on one end</p>	<p>023</p>  <p>DIN 332-D female thread on both ends</p>
<p>030</p>  <p>Radial thread</p>	
<p>031</p>  <p>Radial thread and female thread on one end</p>	<p>032</p>  <p>Radial thread and female thread on both ends</p>
<p>040</p>  <p>Male thread on one end</p>	<p>041</p>  <p>Male thread on both ends</p>
<p>042</p>  <p>Male thread with connection spigot on one end</p>	<p>043</p>  <p>Male thread with connection spigot on both ends</p>
<p>050</p>  <p>Spigot on one end</p>	<p>051</p>  <p>Spigot on both ends</p>
<p>052</p>  <p>Spigot and female thread on one end</p>	<p>053</p>  <p>Spigot and female thread on both ends</p>
<p>054</p>  <p>Side 1: spigot, side 2: male thread</p>	<p>055</p>  <p>Side 1: spigot, side 2: male thread with spigot</p>
<p>056</p>  <p>Side 1: spigot and female thread, side 2: male thread</p>	<p>057</p>  <p>Side 1: spigot and female thread, side 2: male thread with spigot</p>

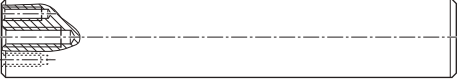
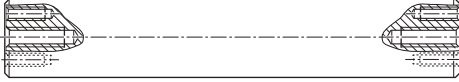
Solid shafts

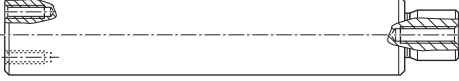
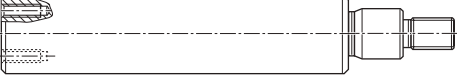
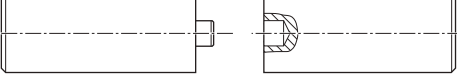
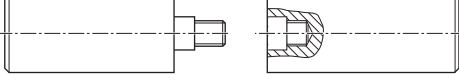
Machining by image number

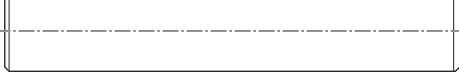
<p>058</p>  <p>Side 1: spigot, side 2: female thread</p>	<p>059</p>  <p>Side 1: male thread, side 2: female thread</p>
<p>060</p>  <p>Side 1: male thread with spigot, side 2: female thread</p>	
<p>070</p>  <p>Pitch circle front thread on one end</p>	<p>071</p>  <p>Pitch circle front thread on both ends</p>
<p>072</p>  <p>Pitch circle front thread and female thread on one end</p>	<p>073</p>  <p>Pitch circle front thread and female thread on both ends</p>
<p>074</p>  <p>Side 1: pitch circle front thread, side 2: female thread</p>	<p>075</p>  <p>Side 1: pitch circle front thread, side 2: spigot and female thread</p>
<p>076</p>  <p>Side 1: pitch circle front thread, side 2: male thread with spigot</p>	
<p>080</p>  <p>Push fit fitting</p>	<p>081</p>  <p>Threaded fitting</p>
<p>090</p>  <p>Annealed on one end</p>	<p>091</p>  <p>Annealed on both ends</p>

This is only a small portion of our diverse machining options. Other machining options available upon request.



Precision steel shafts

Shaft machining





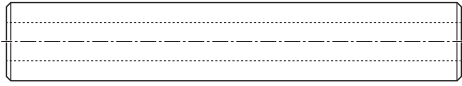
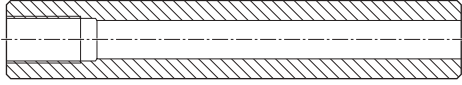
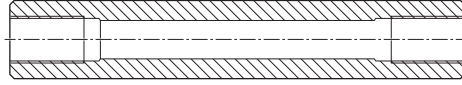
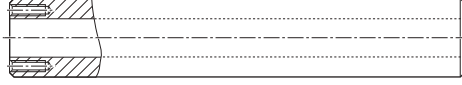
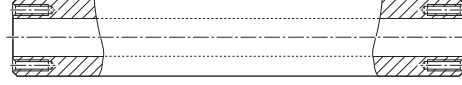
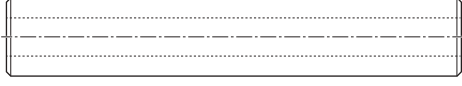
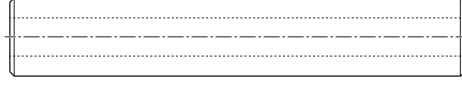

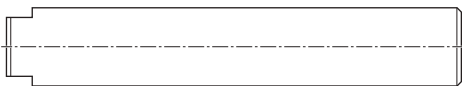

Hollow shafts

Machining by image number

<p>110</p>  <p>Planar and rotated to length tolerance</p>	
<p>120</p>  <p>Female thread on one end</p>	<p>121</p>  <p>Female thread on both ends</p>
<p>170</p>  <p>Pitch circle front thread on one end</p>	<p>171</p>  <p>Pitch circle front thread on both ends</p>
<p>190</p>  <p>Annealed on one end</p>	<p>191</p>  <p>Annealed on both ends</p>

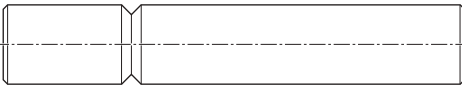
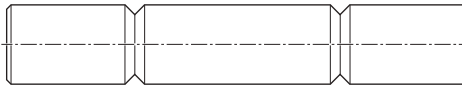
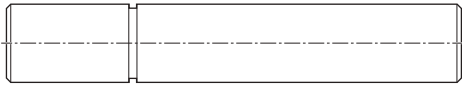
Options

The standard shaft machining options shown above can be supplemented with the following options.

<p>900</p>  <p>L-form wrench size</p>	<p>901</p>  <p>U-form wrench size</p>
<p>902</p>  <p>L-form plane</p>	<p>903</p>  <p>U-form plane</p>
<p>904</p>  <p>90° groove on one end</p>	<p>905</p>  <p>90° groove on both ends</p>
<p>906</p>  <p>DIN 471 groove on one end</p>	<p>907</p>  <p>DIN 471 groove on both ends</p>
<p>909</p>  <p>90° countersink on one end</p>	<p>910</p>  <p>90° countersink on both ends</p>

This is only a small portion of our diverse machining options. Other machining options available upon request.

Benefits

- Diverse machining options
- Short delivery time
- Low cost

Tapped and untapped radial holes

Radial holes are necessary for supporting steel shafts. Radial holes are made in steel shafts that have already been hardened and polished.

Hole diameter, depth and spacing depend on the diameter of the shaft. The tables in Section "Steel shafts with ready-mounted shaft support rails" contain reference values.

Ordering

- Request with customer drawing or
- Use the shaft configuration tool www.boschrexroth.com/shaft-configuration

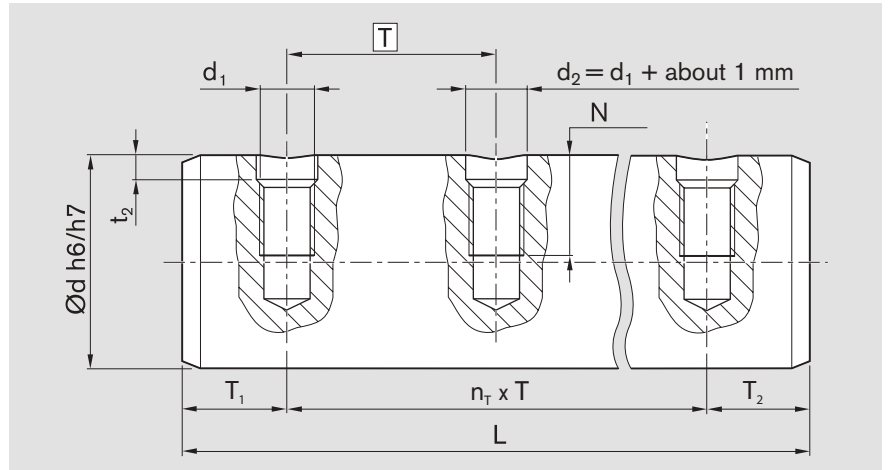

Reference values for drilling out the hardened surface zone

Dimensions (mm)		
Ø d	d ₁	t ₂
12	M4	2.5
16	M5	2.5
20	M6	3.0
25	M8	3.0
30	M10	3.5
40	M10	4.0
40	M12	4.5

Dimensions (mm)		
Ø d	d ₁	t ₂
50	M12	4.0
50	M14	4.5
50	M16	5.0
60	M14	5.5
60	M20	6.5
80	M16	5.5
80	M24	6.5

Values for stainless steel shafts available upon request.

See Section "Steel shafts with ready-mounted shaft support rails" for matching shaft support rails.

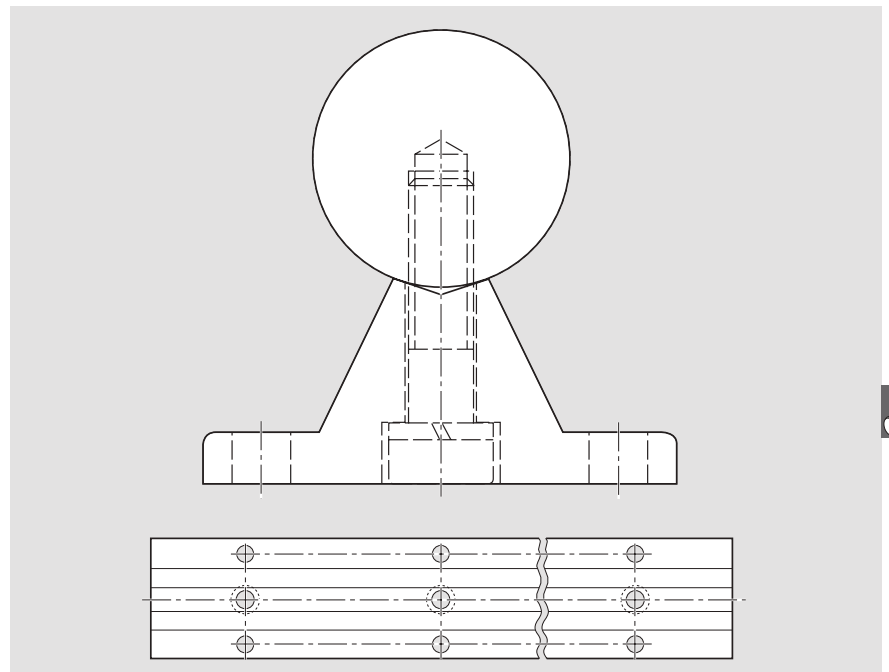

Precision steel shafts

Shaft machining

(Recommendation)

DIN 6885-1 keyway

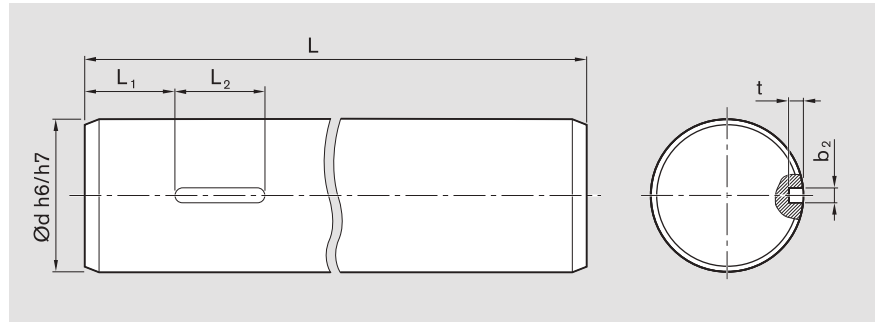

Recommended dimensions:

Dimensions (mm)			Dimensions (mm)		
Shaft Ø d	b ₂ P9	t	Shaft Ø d	b ₂ P9	t
8	2	1.2 ^{+0.1}	25	8	4.0 ^{+0.2}
10	3	1.8 ^{+0.1}	30	8	4.0 ^{+0.2}
12	4	2.5 ^{+0.1}	40	12	5.0 ^{+0.2}
14	5	3.0 ^{+0.1}	50	14	5.5 ^{+0.2}
16	5	3.0 ^{+0.1}	60	18	7.0 ^{+0.2}
20	6	3.5 ^{+0.1}	80	22	9.0 ^{+0.2}

Groove for DIN 471 retaining ring

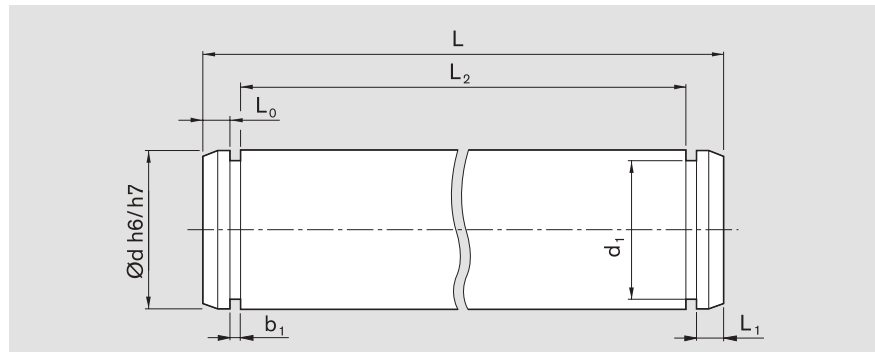

Recommended dimensions

Dimensions (mm)			DIN 471 retaining ring	
Ø d	b ₁ +0.1	d ₁	Dimensions (mm)	Material number
4	0.50	3.8 -0.04	4x0.4	R3410 765 00
5	0.70	4.8 -0.04	5x0.6	R3410 742 00
8	0.90	7.6 -0.06	8x0.8	R3410 737 00
10	1.10	9.6 -0.11	10x1	R3410 745 00
12	1.10	11.5 -0.11	12x1	R3410 712 00
14	1.10	13.4 -0.11	14x1	R3410 747 00
16	1.10	15.2 -0.11	16x1	R3410 713 00
20	1.30	19 -0.13	20x1.2	R3410 735 00
25	1.30	23.9 -0.21	25x1.2	R3410 750 00
30	1.60	28.6 -0.21	30x1.5	R3410 724 00
40	1.85	37.5 -0.25	40x1.75	R3410 726 00
50	2.15	47.0 -0.25	50x2	R3410 727 00
60	2.15	57.0 -0.30	60x2	R3410 764 00
80	2.65	76.5 -0.30	80x2.5	-

90° countersink

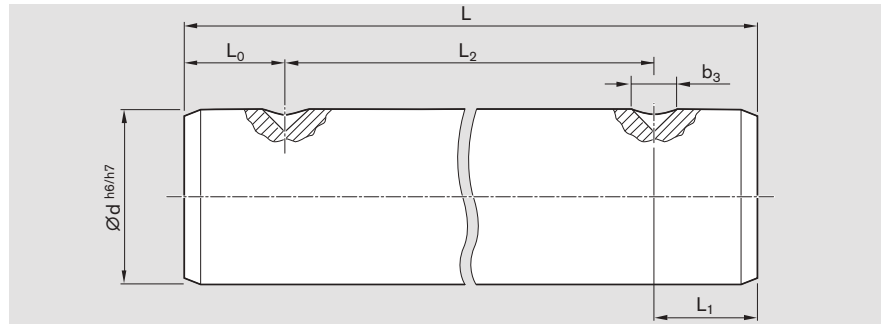

Recommended dimensions

	Dimensions (mm)													
$\varnothing d$	4	5	8	10	12	14	16	20	25	30	40	50	60	80
b_3	-	3	4	5	5	5	5	5	6	6	8	8	8	10

Pitch circle female thread

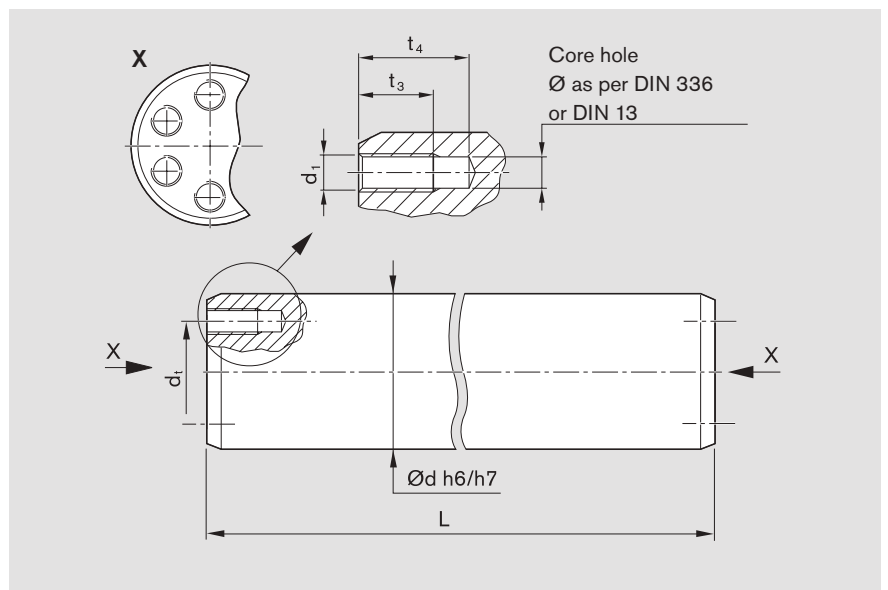

Steel shafts with shaft support rails ready-mounted, shaft support rails

Product overview

Benefits

- For use with open linear bushings
- For long guides or heavy loads where self-supporting shafts cannot be used due to shaft warping
- Unlimited length when using interconnecting shafts
- Support rails for various requirements
- Additional degrees of freedom in circumferential direction compared to profiled rail systems
- For applications where other linear guides tend to warp due to imprecise substructures.

General

The individual supports are arranged under each shaft and separated only by installation seams. The tolerances specified in the dimension tables refer to after alignment and installation of the guide units on a torsion-resistant, faced mounting base.

R1010 Precision steel shaft with ready-mounted aluminum shaft support rails, flanged, highly affordable

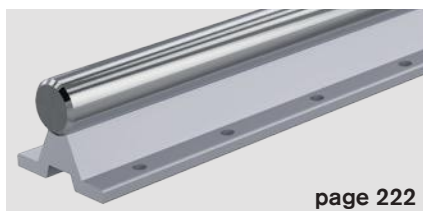

page 222

R1011 Precision steel shaft with ready-mounted aluminum shaft support rails, flanged, highly affordable

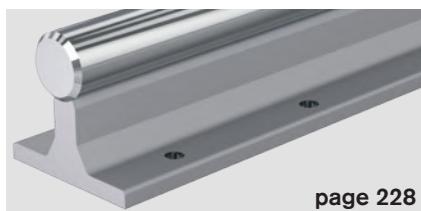

page 228

R1014 Precision steel shaft with ready-mounted aluminum shaft support rails, flanged, extremely high height tolerance

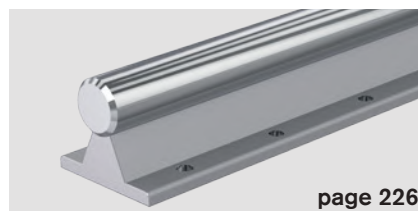

page 226

R1025 same as R1010, but hole spacing for profile systems

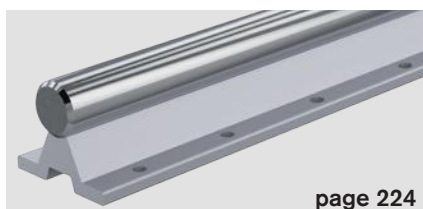

page 224

Steel shafts with shaft support rails

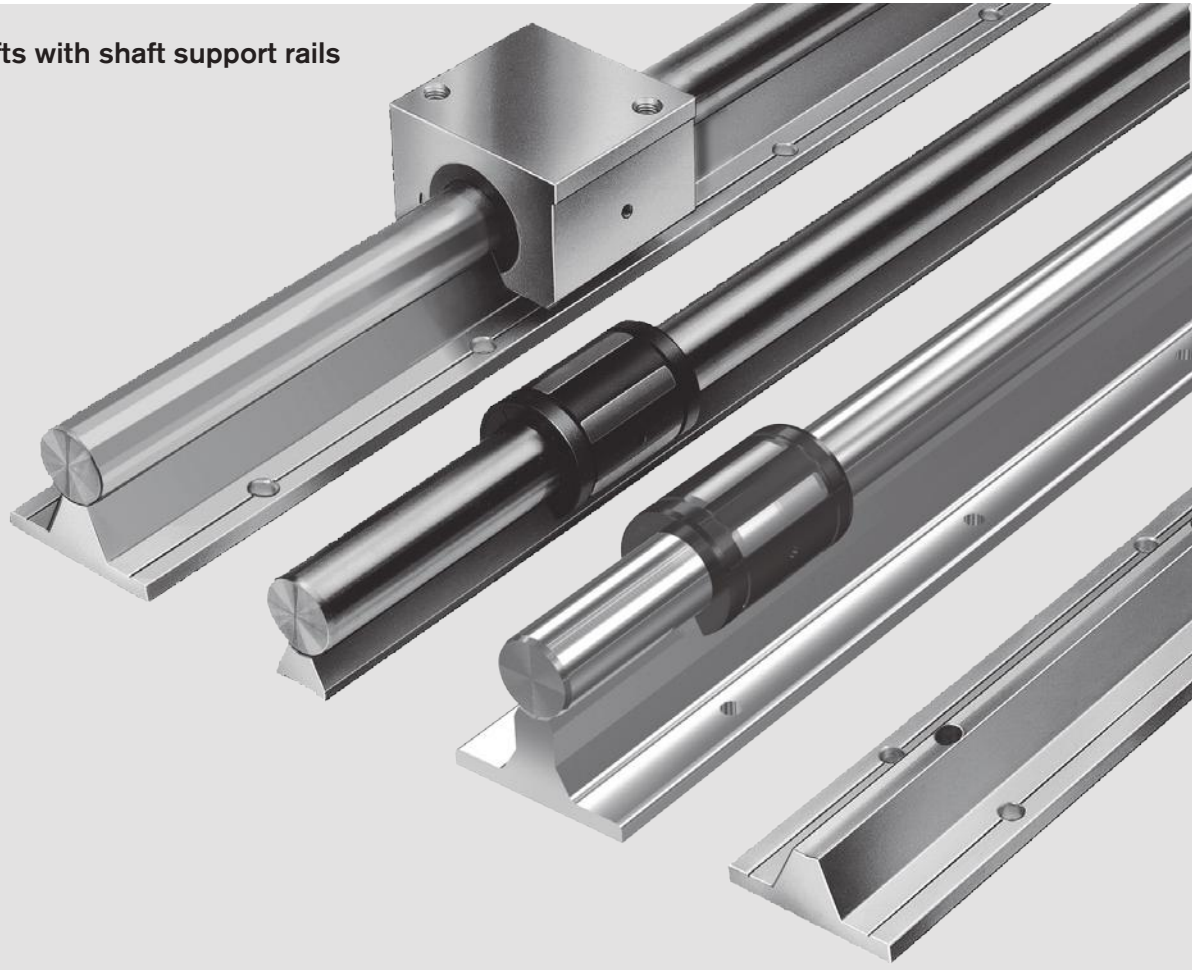

R1015 Precision steel shaft with ready-mounted aluminum shaft support rails, side mounting

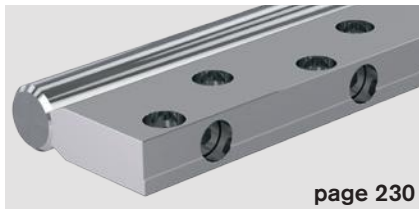

R1013 Precision steel shaft with ready-mounted aluminum shaft support rail, flangeless, highly affordable

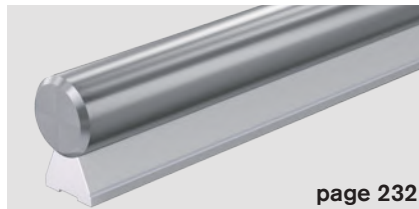

R1016 Precision steel shaft with ready-mounted steel shaft support rail, flangeless, with reference edge

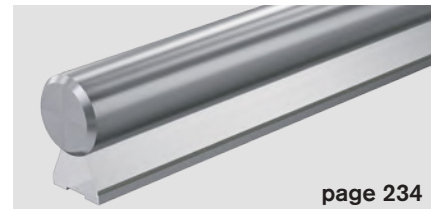

Shaft support rails for radial compact set and radial linear bushing:

R1018



R1012



Steel shafts with ready-mounted shaft support rails

Design, ordering information, installation

Terminals T_1 and T_2

If the ordered shaft length corresponds to the whole multiple of the hole spacing of one shaft support rail, the terminals correspond to half of the spacing length (T_1 and $T_2 = T \div 2$). The holes are calculated by us for other lengths ($T_1 \neq T_2$). This is done by shortening any excess shaft support rails on either end. Both terminals T_1 and T_2 should not be less than $0.2 \times T$.

If no customer drawings are available, we will include the hole spacing calculated by us for the steel shaft in the quotation and order confirmation. This produces the locations of the mounting holes in the machine bed.

We recommend comparing these specifications with the design documents.

Ordering information: Material number R10.. /length x mm/ T_1 x mm/ T_2 x mm

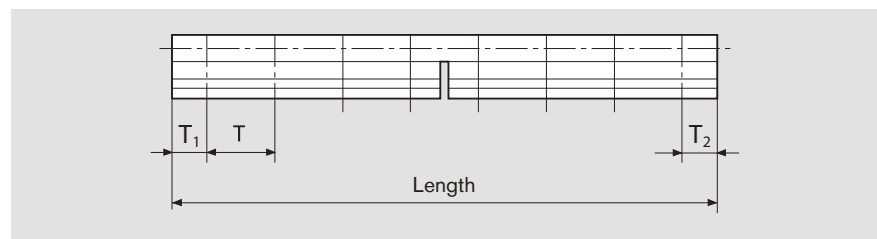

Excess and combined guide units

A section of shaft with ready-mounted shaft support rail should not exceed 6 m. Individual sections are combined to form longer lengths (see Section "Combined shafts, connections").

The joints between shafts and shaft support rails are arranged differently depending on the model. However, the shaft joint should generally be offset from the shaft support rail seam.

Special hole spacing

Shafts with ready-mounted shaft support rails also come with special hole spacings upon the customer's request.

Note on installing flangeless shaft support rails

We recommend using a taper gib or clamping strip to secure the shaft support rail in order to make installation easier or when there is significant lateral load.

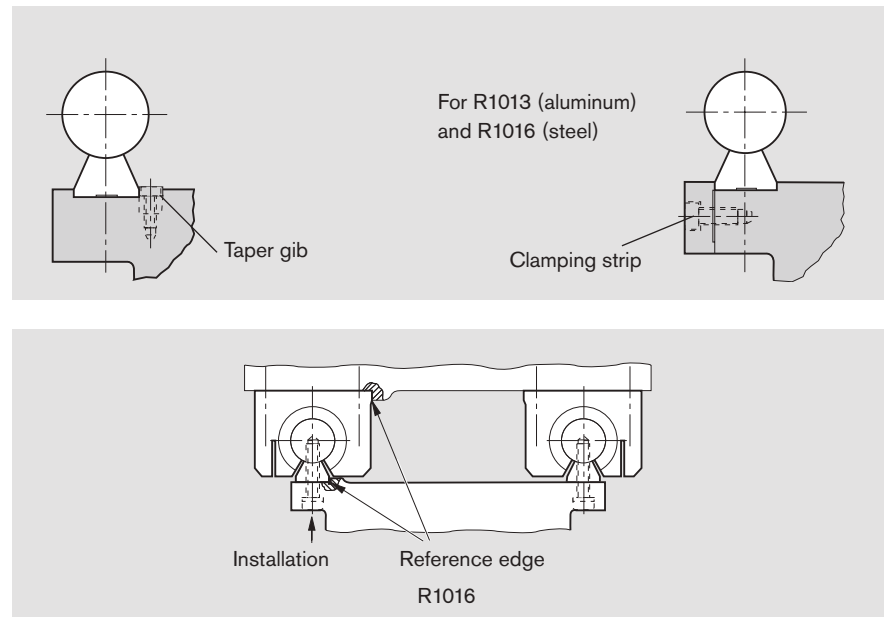

The shaft support rail must be straight during installation.

To do this, press the first shaft with shaft support rail onto the reference edge and fasten it down, then align and fasten down the second shaft, preferably using a rod. These elements only come with precision steel shafts.

The maximum length of the shaft support rail is 1,800 mm and these are joined to create longer lengths. The reference edge allows the shaft support rails to be aligned easily to avoid distortive stress on the linear bushings.



Steel shafts with ready-mounted shaft support rails for open standard and super linear bushings

Flanged

R1010 steel shaft with ready-mounted shaft support rail

Material

- Shaft support rail: Aluminum

Design

- Combined with linear sets, these shaft support rails can be used to create linear guides with very low height.
- High rigidity Carefully adapting the support rail to the linear bushing size produces the ideal pressure angle for fitting the shaft, which ensures high rigidity along with the large fastening bolts.
- Highly affordable

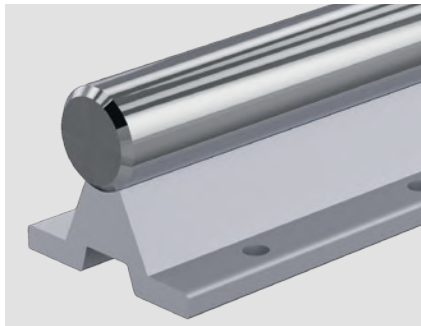

Shaft Ø d (mm)	Material number		Weight (kg/m)
	Hole spacing type 1	Hole spacing type 2	
16	R1010 016 ..	R1010 516 ..	2.5
20	R1010 020 ..	R1010 520 ..	3.8
25	R1010 025 ..	R1010 525 ..	5.4
30	R1010 030 ..	R1010 530 ..	7.6
40	R1010 040 ..	R1010 540 ..	12.6

Shafts:

- 00 = h6 heat-treated steel
- 01 = h7 heat-treated steel
- 30 = h6 stainless steel
- 31 = h7 stainless steel
- 60 = h6 hard chrome-plated heat-treated steel
- 61 = h7 hard chrome-plated heat-treated steel

Ordering example:

Shaft diameter 30 mm, h7, heat-treated steel, 900 mm long, ready-mounted shaft support rail type 1:

R1010 030 01/900 mm.

Dimensions

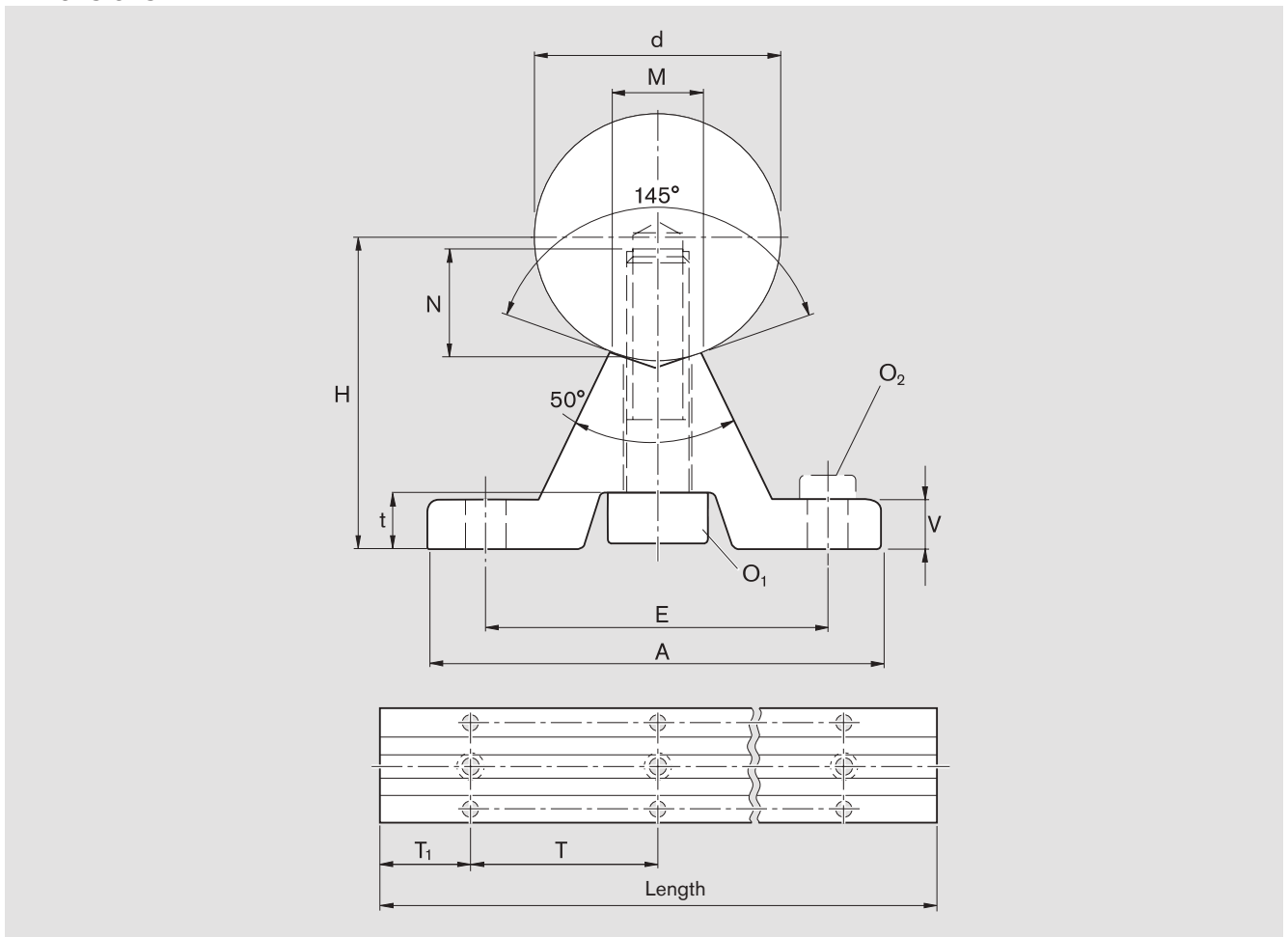

Dimensions (mm)										
$\varnothing d$	$H^{1)}$ ± 0.1	A	V	M	O_1 DIN 6912-8.8	N	E	t	$O_2^{2)}$ DIN 6912-8.8	Mt ³⁾ Type 1 Type 2
16	26	45	5	7.0	M5x20	9	33	6.0	M5x16	100 150
20	32	52	6	8.3	M6x25	11	37	7.0	M6x16	100 150
25	36	57	6	10.8	M8x30	15	42	7.0	M6x16	120 200
30	42	69	7	11.0	M10x35	17	51	7.5	M8x25	150 200
40	50	73	8	15.0	M10x40	19	55	7.0	M8x25	200 300

1) Measured with gauging shaft, nominal dimension d and length about 50 mm. Up to 1,800 mm length with parallelism of 0.1 mm available upon request.

2) Only applicable for bolting with steel or cast iron threads.

3) Type 1: For transverse loads on the linear bushing opening and when approaching maximum load.

Type 2: For general requirements.



Steel shafts with ready-mounted shaft support rails for open standard and super linear bushings

For profile systems

R1025 steel shaft with ready-mounted shaft support rail¹⁾

Material

- Shaft support rail: Aluminum

Design

- Fast, easy, modular linear bushing guide design for profile systems
- Highly affordable due to less stringent height tolerance

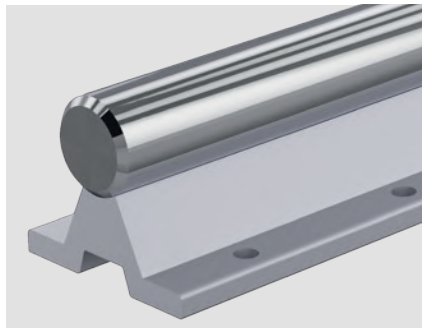
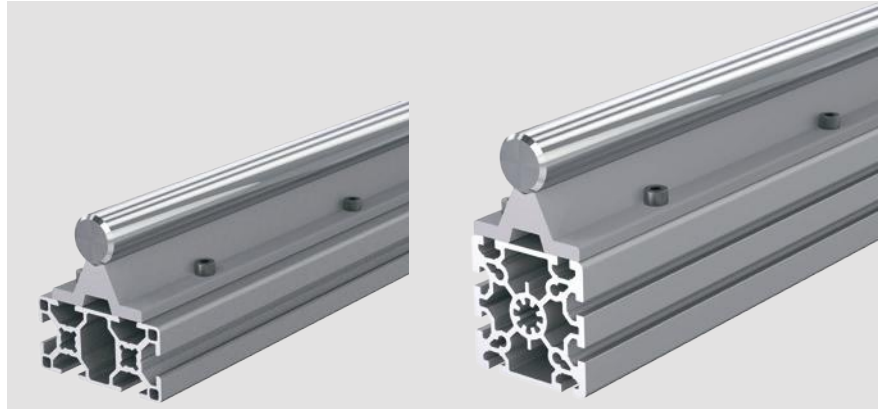

Shaft Ø d (mm)	Modular dimension E (mm)	Material number	Weight (kg/m)
20	40	R1025 020 ..	3.8
25	40	R1025 025 ..	5.4
30	45	R1025 530 ..	7.5
30	50	R1025 030 ..	7.5

Shafts:

- 00 = h6 heat-treated steel
- 01 = h7 heat-treated steel
- 30 = h6 stainless steel
- 31 = h7 stainless steel
- 60 = h6 hard chrome-plated heat-treated steel
- 61 = h7 hard chrome-plated heat-treated steel

1) Ordering example:

Shaft diameter 25 mm, h7, heat-treated steel, 900 mm long, ready-mounted shaft support rail:

R1025 025 01/900 mm.

R1039 shaft support rail, drilled



Shaft Ø d (mm)	Modular dimension E (mm)	Material number	Weight (kg/m)	Length (mm)
				-0.5 -1.5
20	40	R1039 820 30	1.3	1,800
25	40	R1039 825 30	1.6	1,800
30	45	R1039 930 30	2.0	1,800
30	50	R1039 830 30	2.0	1,800

R1039 shaft support rail, undrilled

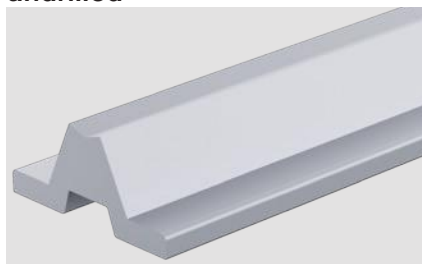

Shaft Ø d (mm)	Material number	Weight (kg/m)	Length (mm)
			-0.5 -1.5
20	R1039 520 30	1.3	1,800
25	R1039 525 30	1.6	1,800
30	R1039 530 30	2.0	1,800

Dimensions

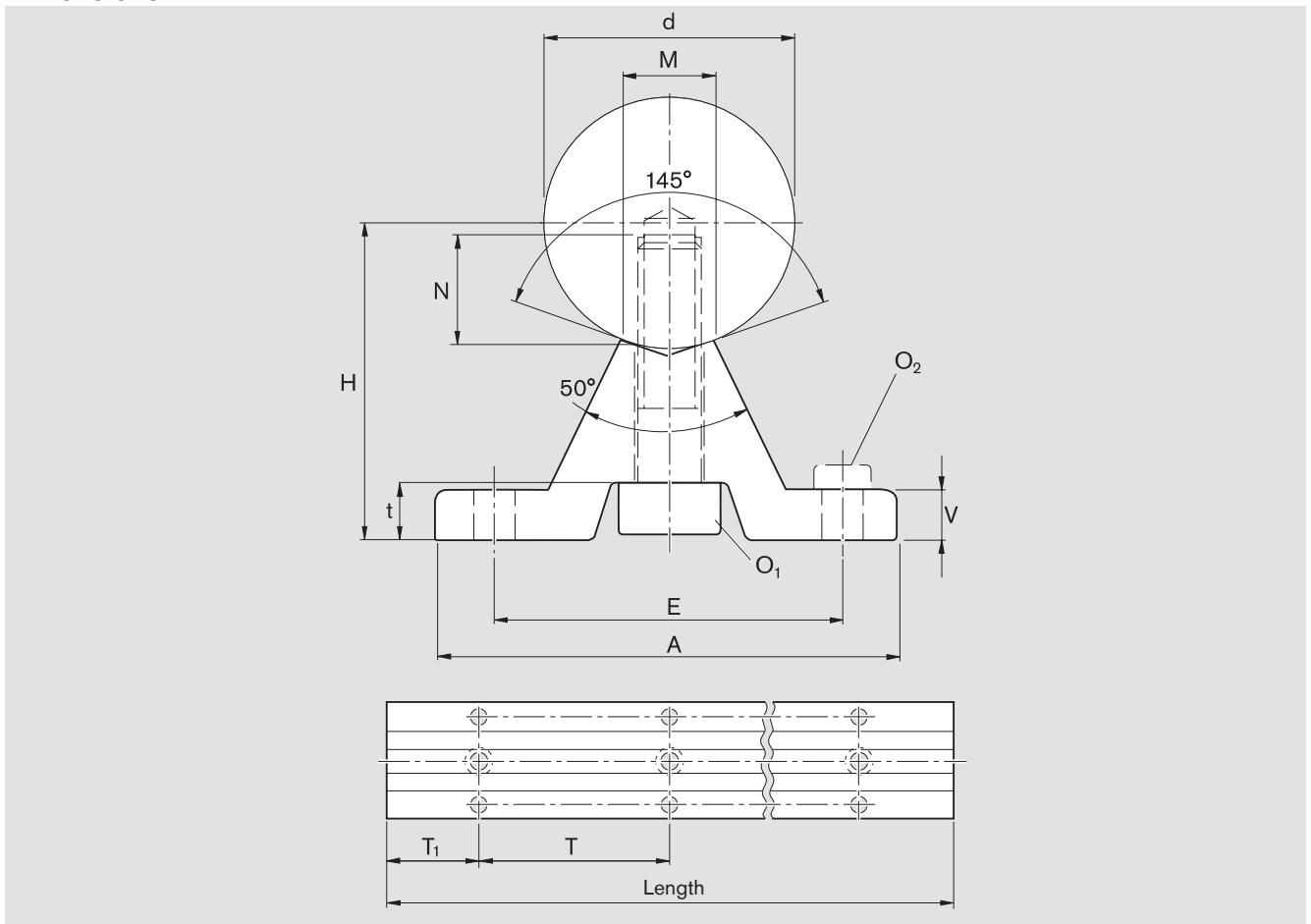

Dimensions (mm)											
$\varnothing d$	$H^{1)}$ ± 0.1	A	V	M	O_1 DIN 6912-8.8	N	E	t	O_2 DIN 6912-8.8	T	
							Modular dimension				
20	32	52	6	8.3	M6x25	11	40	7.0	M6		180
25	36	57	6	10.8	M8x30	15	40	7.0	M6		180
30	42	69	7	11.0	M10x35	17	45	7.5	M8		180
30	42	69	7	11.0	M10x35	17	50	7.5	M8		180

1) Measured with gauging shaft, nominal dimension d and length about 50 mm. Up to 1,800 mm length with parallelism of 0.1 mm available upon request.

See "Basic mechanical elements" catalog for profile systems.



Steel shafts with ready-mounted shaft support rails for open standard and super linear bushings

Flanged, extremely accurate height tolerance

R1014 steel shaft with ready-mounted shaft support rail

Material

- Shaft support rail: Aluminum

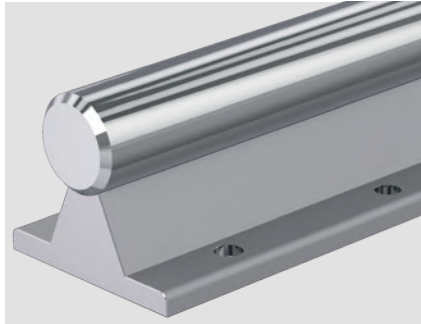

Design

- Combined with linear sets, these shaft support rails can be used to create linear guides with very low height.
- High rigidity Carefully adapting the support rail to the linear bushing size produces the ideal pressure angle for fitting the shaft, which ensures high rigidity along with the large fastening bolts.

Shaft Ø d (mm)	Material number		Weight (kg/m)
	Type 1	Type 2	
12	R1014 012 ..	R1014 512 ..	1.75
16	R1014 016 ..	R1014 516 ..	2.65
20	R1014 020 ..	R1014 520 ..	3.95
25	R1014 025 ..	R1014 525 ..	5.6
30	R1014 030 ..	R1014 530 ..	7.9
40	R1014 040 ..	R1014 540 ..	12.8
50	R1014 050 ..	R1014 550 ..	19.4
60	R1014 060 ..	–	27.3
80	R1014 080 ..	–	47.3

Shafts:

- 00 = h6 heat-treated steel
- 01 = h7 heat-treated steel
- 30 = h6 stainless steel
- 31 = h7 stainless steel
- 60 = h6 hard chrome-plated heat-treated steel
- 61 = h7 hard chrome-plated heat-treated steel

Ordering example:

Shaft diameter 30 mm, h6, heat-treated steel, 1,200 mm long, ready-mounted shaft support rail type 1 R1050 630 00 is ordered as:

R1014 030 00/1,200 mm.

R1050 shaft support rails, drilled, length (mm) 600^{-0.5}_{-1.5}



Shaft Ø d (mm)	Material number		Weight (kg/m)
	Type 1	Type 2	
12	R1050 612 00	R1050 712 00	0.52
16	R1050 616 00	R1050 716 00	0.64
20	R1050 620 00	R1050 720 00	0.90
25	R1050 625 00	R1050 725 00	1.08
30	R1050 630 00	R1050 730 00	1.43
40	R1050 640 00	R1050 740 00	1.81
50	R1050 650 00	R1050 750 00	2.45
60	R1050 660 00	–	3.16
80	R1050 680 00	–	4.86

R1050 shaft support rails, un-drilled, length (mm) 600^{-0.5}_{-1.5}

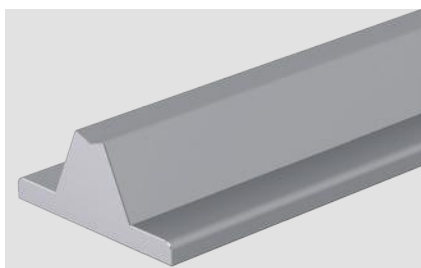

Shaft Ø d (mm)	Material number	Weight (kg/m)
12	R1050 512 00	0.52
16	R1050 516 00	0.64
20	R1050 520 00	0.90
25	R1050 525 00	1.08
30	R1050 530 00	1.43
40	R1050 540 00	1.81
50	R1050 550 00	2.45
60	R1050 560 00	3.16
80	R1050 580 00	4.86

Dimensions

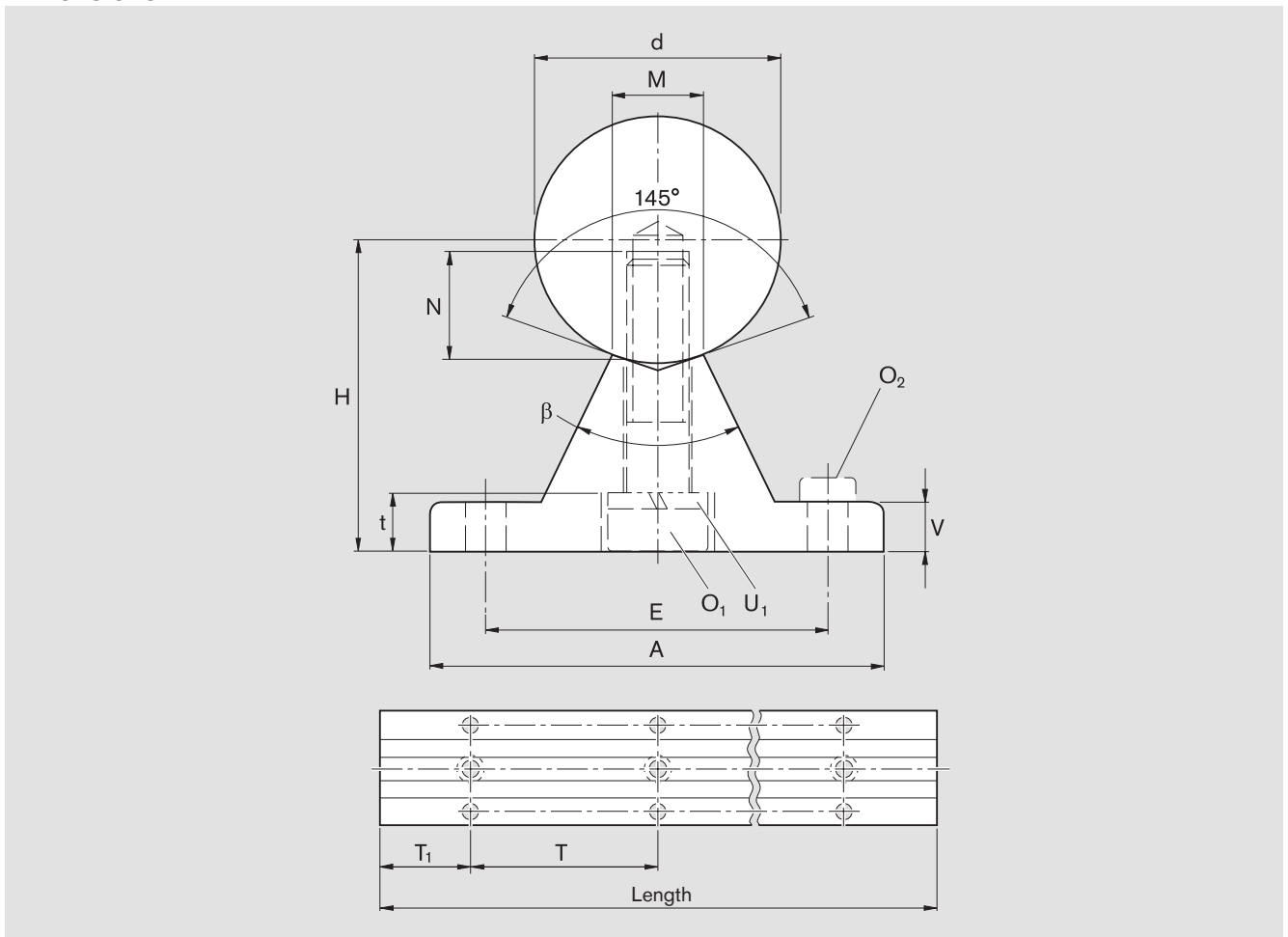

Dimensions (mm)													Angle	
Ø d	H ¹⁾ ±0.01	A	V	M	O ₁ DIN 6912-8.8	N	U ₁ DIN 7980 ²⁾	E	t	O ₂ ³⁾ DIN 6912-8.8	Type 1	Mt ⁴⁾ Type 2	β (°)	
12	22	40	5	5.8	M4x20	8	4	29	4.5	M4x12	75	120	50	
16	26	45	5	7.0	M5x20	9	5	33	7.6	M5x16	100	150	50	
20	32	52	6	8.3	M6x25	11	6	37	8.6	M6x16	100	150	50	
25	36	57	6	10.8	M8x30	15	8	42	9.0	M6x16	120	200	50	
30	42	69	7	11.0	M10x35	17	10	51	10.0	M8x25	150	200	50	
40	50	73	8	15.0	M10x40	19	10	55	9.5	M8x25	200	300	50	
50	60	84	9	19.0	M12x45	21	12	63	11.5	M10x30	200	300	46	
60	68	94	10	25.0	M14x50	25	14	72	13.0	M10x30	300	-	46	
80	86	116	12	34.0	M16x60	28	16	92	15.0	M12x35	300	-	46	

- 1) Measured with gauging shaft, nominal dimension d and length about 50 mm.
- 2) DIN 7980 discontinued. Spring washer commercially available.
- 3) Only applicable for bolting with steel or cast iron threads.
- 4) Type 1: For transverse loads on the linear bushing opening and when approaching maximum load, as well as when dimensional accuracy is strictly required.
Type 2: For general requirements.



Steel shafts with ready-mounted shaft support rails for open standard and super linear bushings

R1011 steel shaft with ready-mounted shaft support rail

Material

– Shaft support rail: Aluminum

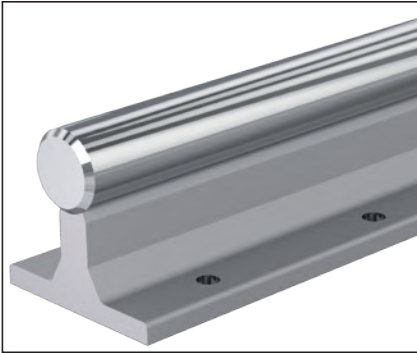

Shaft Ø d (mm)	Material number		Weight (kg/m)
	Type 1	Type 2	
12	R1011 012 ..	R1011 512 ..	1.95
16	R1011 016 ..	R1011 516 ..	2.80
20	R1011 020 ..	R1011 520 ..	4.10
25	R1011 025 ..	R1011 525 ..	5.90
30	R1011 030 ..	R1011 530 ..	8.50
40	R1011 040 ..	R1011 540 ..	13.30
50	R1011 050 ..	R1011 550 ..	20.30

Shafts:

- 00 = h6 heat-treated steel
- 01 = h7 heat-treated steel
- 30 = h6 stainless steel
- 31 = h7 stainless steel
- 60 = h6 hard chrome-plated heat-treated steel
- 61 = h7 hard chrome-plated heat-treated steel

Ordering example:

Shaft diameter 40 mm, h7, stainless steel, 1,100 mm long, ready-mounted shaft support rail type 2 R1050 240 00 is ordered as:

R1011 540 31/1,100 mm.

R1050 shaft support rails, drilled, length (mm) 600^{-0.5}_{-1.5}

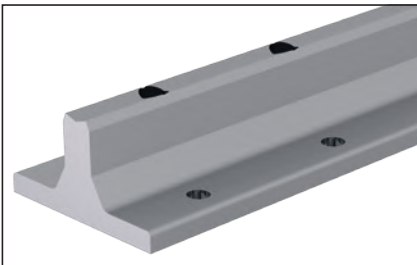

Shaft Ø d (mm)	Material number		Weight (kg)
	Type 1	Type 2	
12	R1050 112 00	R1050 212 00	0.64
16	R1050 116 00	R1050 216 00	0.74
20	R1050 120 00	R1050 220 00	1.00
25	R1050 125 00	R1050 225 00	1.20
30	R1050 130 00	R1050 230 00	1.80
40	R1050 140 00	R1050 240 00	2.10
50	R1050 150 00	R1050 250 00	3.00

R1050 shaft support rails, un-drilled, length (mm) 600^{-0.5}_{-1.5}

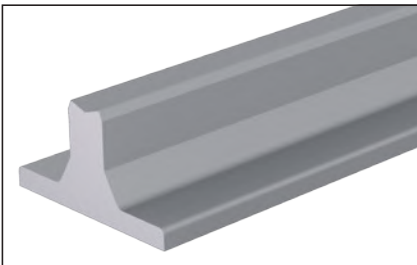

Shaft Ø d (mm)	Material number		Weight (kg)
	Un-drilled		
12	R1050 012 00		0.64
16	R1050 016 00		0.74
20	R1050 020 00		1.00
25	R1050 025 00		1.20
30	R1050 030 00		1.80
40	R1050 040 00		2.10
50	R1050 050 00		3.00

Dimensions

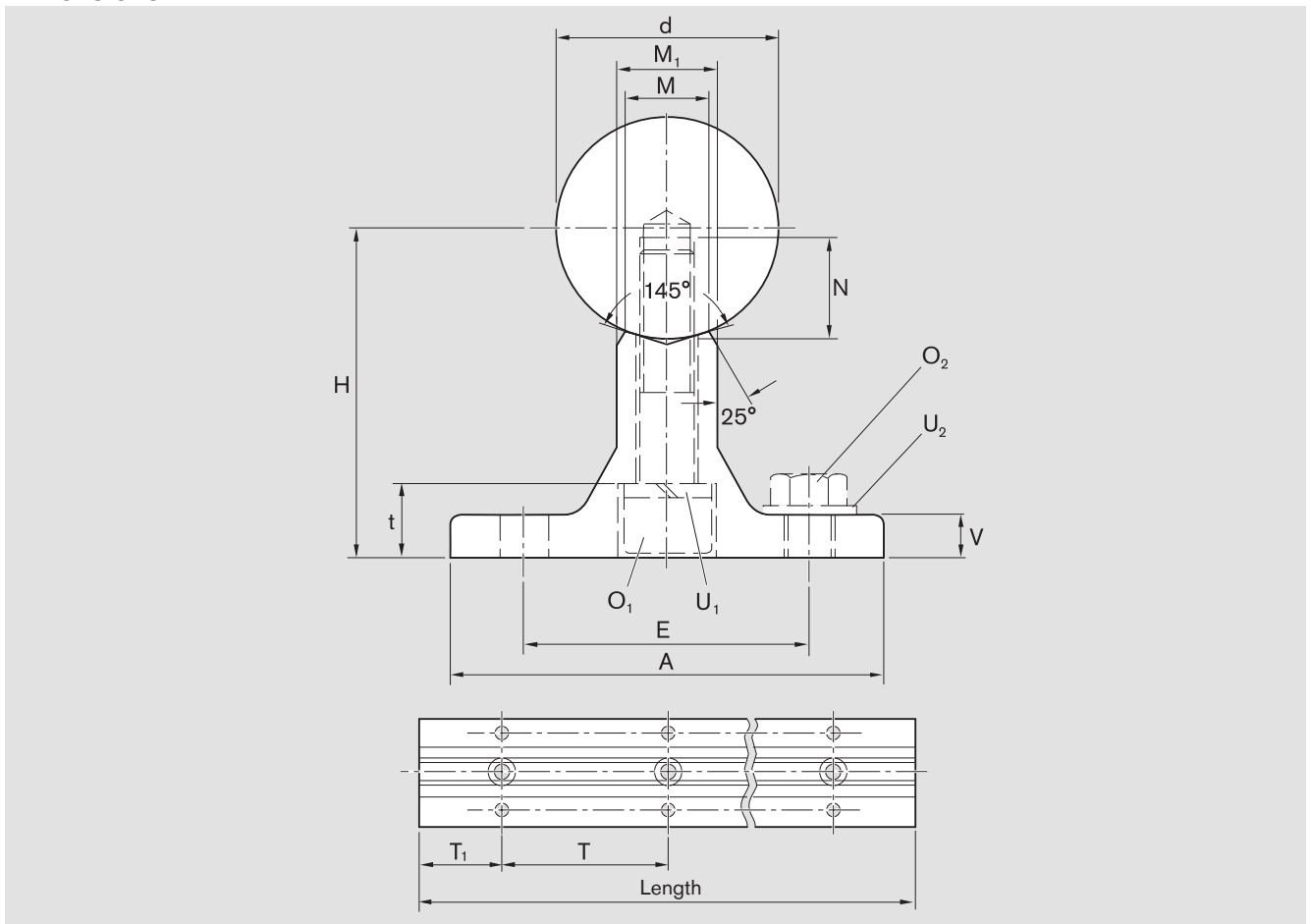

Dimensions (mm)														
$\varnothing d$	$H^1)$ ± 0.05	A	V	M	M_1	O_1 ISO 4762-8.8	U_1 DIN 7980 ²⁾	N	E	t	$O_2^3)$ ISO 4762-8.8 or ISO 4017-8.8	U_2 DIN 125	$Mt^4)$ Type 1	Type 2
12	28	43	5	5.8	9	M4x25	4	8	29	5.5	M4x12	4	75	120
16	30	48	5	7.0	10	M5x25	5	9	33	7.0	M5x16	5	100	150
20	38	56	6	8.3	11	M6x30	6	11	37	9.6	M6x16	6	100	150
25	42	60	6	10.8	14	M8x35	8	15	42	11.0	M6x16	6	120	200
30	53	74	8	11.0	14	M10x40	10	17	51	14.0	M8x25	8	150	200
40	60	78	8	15.0	18	M10x45	10	19	55	13.5	M8x25	8	200	300
50	75	90	10	19.0	22	M12x55	12	21	63	16.0	M10x30	10	200	300

- 1) Measured with gauging shaft, nominal dimension d and length about 50 mm.
- 2) DIN 7980 discontinued. Spring washer commercially available.
- 3) Only applicable for bolting with steel or cast iron threads.
- 4) Type 1: For transverse loads on the linear bushing opening and when approaching maximum load, as well as when dimensional accuracy is strictly required.
Type 2: For general requirements.



Steel shafts with ready-mounted shaft support rails for open standard and super linear bushings

Side mounting

R1015 steel shaft with ready-mounted shaft support rail

R1054 shaft support rails

Material

- Shaft support rail: Aluminum

Design

- Combine with linear sets with side opening for heavy-duty linear guides
- Reference edge makes aligning easier (installation)

Type 1

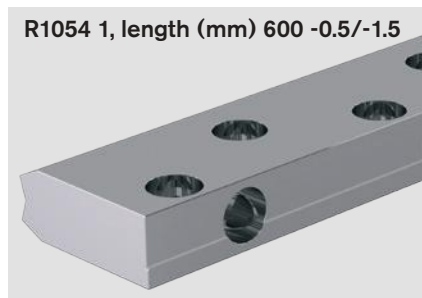
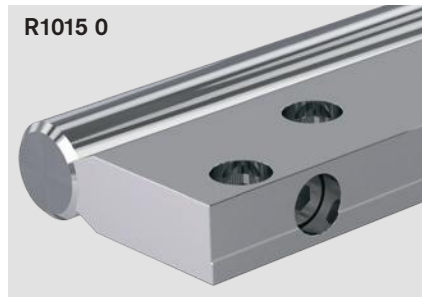

Shaft Ø d (mm)	Material number	Weight (kg)	Material number	Weight (kg)
20	R1015 020 ..	4.1	R1054 120 00	1.0
25	R1015 025 ..	6	R1054 125 00	1.3
30	R1015 030 ..	8.7	R1054 130 00	1.9
40	R1015 040 ..	14.3	R1054 140 00	2.7
50	R1015 050 ..	21.5	R1054 150 00	3.7

Shafts:

- 00 = h6 heat-treated steel
- 01 = h7 heat-treated steel
- 30 = h6 stainless steel
- 31 = h7 stainless steel
- 60 = h6 hard chrome-plated heat-treated steel
- 61 = h7 hard chrome-plated heat-treated steel

Type 2

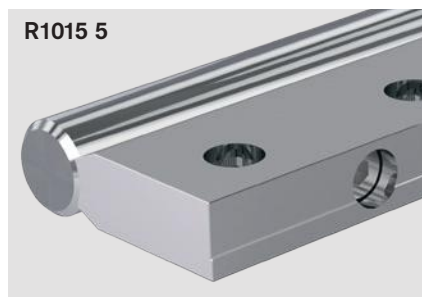

Shaft Ø d (mm)	Material number	Weight (kg)	Material number	Weight (kg)
20	R1015 520 ..	4.3	R1054 220 00	1.1
25	R1015 525 ..	6.3	R1054 225 00	1.5
30	R1015 530 ..	9	R1054 230 00	2.1
40	R1015 540 ..	14.8	R1054 240 00	3.0
50	R1015 550 ..	22.3	R1054 250 00	4.2

Shafts:

- 00 = h6 heat-treated steel
- 01 = h7 heat-treated steel
- 30 = h6 stainless steel
- 31 = h7 stainless steel
- 60 = h6 hard chrome-plated heat-treated steel
- 61 = h7 hard chrome-plated heat-treated steel

Ordering example:

Shaft diameter 30 mm, h6, heat-treated steel, 1,200 mm long, ready-mounted shaft support rail type 1 R1054 130 00 is ordered as:

R1015 030 00/1,200 mm.

Dimensions

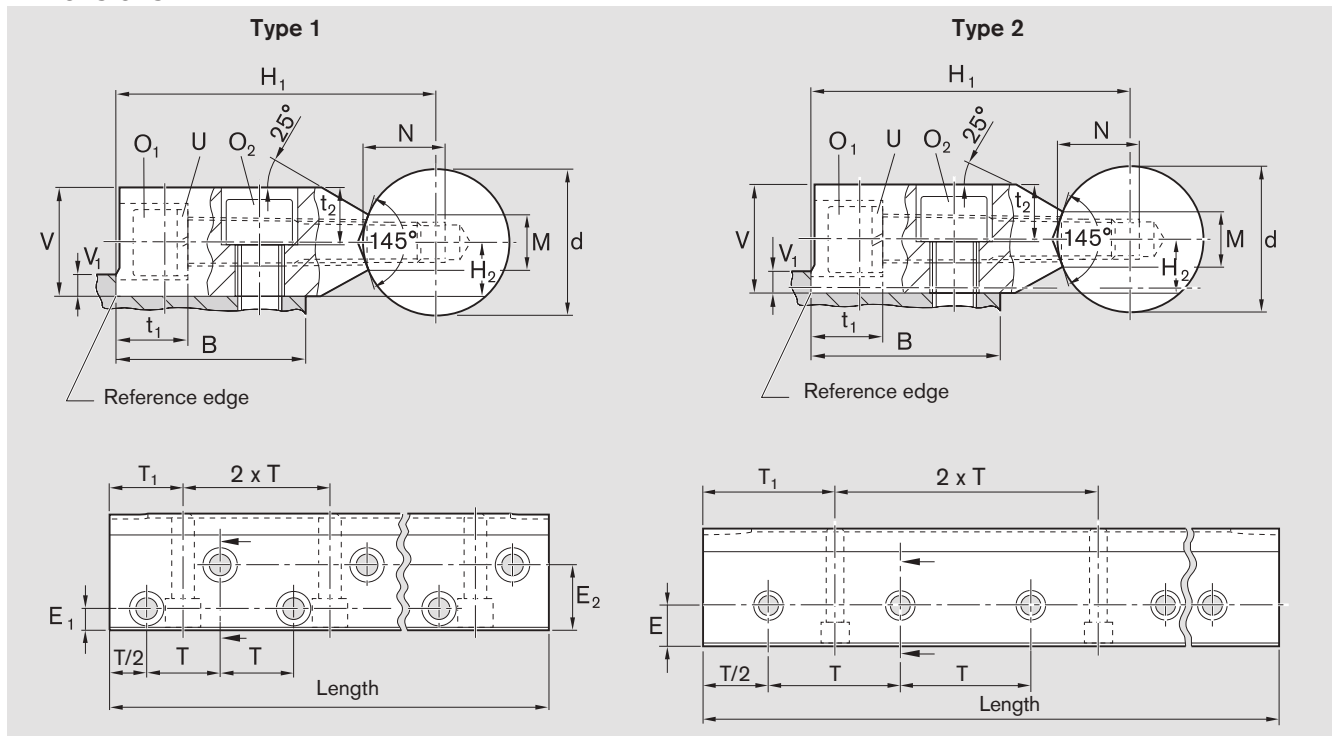

Shaft support rail type 1

Dimensions (mm)																	
$\varnothing d$	$H_1^{1)}$ js6	$H_2^{1)}$ ± 0.012	V	M	E_1 ± 0.15	E_2 ± 0.15	T	t_1	t_2	$V_1^{2)}$ max.	$B^{2)}$	N	O_1 ISO 4762-8.8	$O_2^{3)}$ ISO 4762-8.8	DIN 7980 ⁴⁾		U
20	52	7.5	15	8.3	8	22	37.5	8.5	8.5	4.0	30	11	M6x45	M6x16			6
25	62	10.0	20	10.8	10	26	37.5	15.0	11.0	5.5	36	15	M8x50	M8x20			8
30	72	12.5	25	11.0	12	30	50.0	15.3	13.5	7.0	42	17	M10x60	M10x25			10
40	88	15.0	30	15.0	12	38	50.0	19.0	16.0	8.5	50	21	M12x70	M12x30			12
50	105	17.5	35	19.0	15	45	50.0	24.0	18.5	9.0	60	25	M14x80	M14x35			14

Shaft support rail type 2

Dimensions (mm)																	
$\varnothing d$	$H_1^{1)}$ js6	$H_2^{1)}$ ± 0.012	V	M	E ± 0.15	T	t_1	t_2	$V_1^{2)}$ max.	$B^{2)}$	N	O_1 ISO 4762-8.8	$O_2^{3)}$ ISO 4762-8.8	DIN 7980 ⁴⁾		U	
20	52	7.5	15	8.3	15	50	8.5	8.5	4.0	30	11	M6x45	M6x16			6	
25	62	10.0	20	10.8	18	60	15.0	11.0	5.5	36	15	M8x50	M8x20			8	
30	72	12.5	25	11.0	21	75	15.3	13.5	7.0	42	17	M10x60	M10x25			10	
40	88	15.0	30	15.0	25	100	17.5	16.0	8.5	50	19	M10x70	M12x30			10	
50	105	17.5	35	19.0	30	100	21.5	18.5	9.0	60	21	M12x80	M14x35			12	

- 1) Measured with gauging shaft, nominal dimension d and length about 50 mm.
- 2) Recommended design: No reference edge on opposite side (V_1), align parallel over shafts.
- 3) Recommendation applies only for bolting in steel or cast iron threads.
- 4) DIN 7980 discontinued. Spring washer commercially available.



Steel shafts with ready-mounted shaft support rails for open standard and super linear bushings

Flangeless

R1013 steel shaft with ready-mounted shaft support rail

Material

- Shaft support rail: Aluminum

Design

- This shaft support rail helps create highly compact guides and is designed for when installing the steel shaft from underneath. Compared to conventional flanged versions (see figure), this element has extremely low height.
- Highly affordable

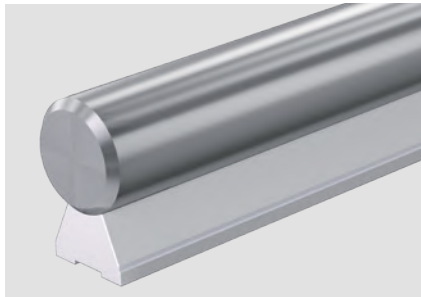
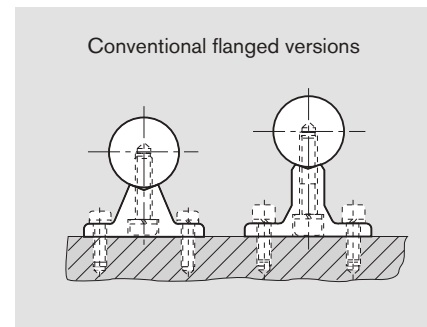
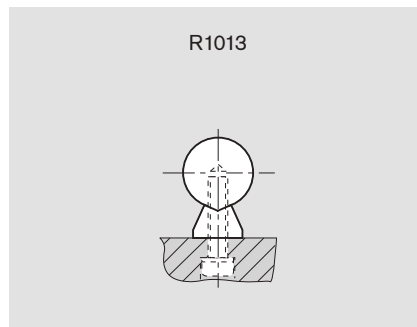

Shaft Ø d (mm)	Material number	Weight (kg/m)
12	R1013 012 ..	1.1
16	R1013 016 ..	1.9
20	R1013 020 ..	3.0
25	R1013 025 ..	4.5
30	R1013 030 ..	6.3

Shafts:	
— 00 =	h6 heat-treated steel
— 01 =	h7 heat-treated steel
— 30 =	h6 stainless steel
— 31 =	h7 stainless steel
— 60 =	h6 hard chrome-plated heat-treated steel
— 61 =	h7 hard chrome-plated heat-treated steel

Ordering example:

Shaft diameter 25 mm, h7, heat-treated steel, 1,500 mm long, ready-mounted shaft support rail:

R1013 025 01/1500 mm.

Dimensions

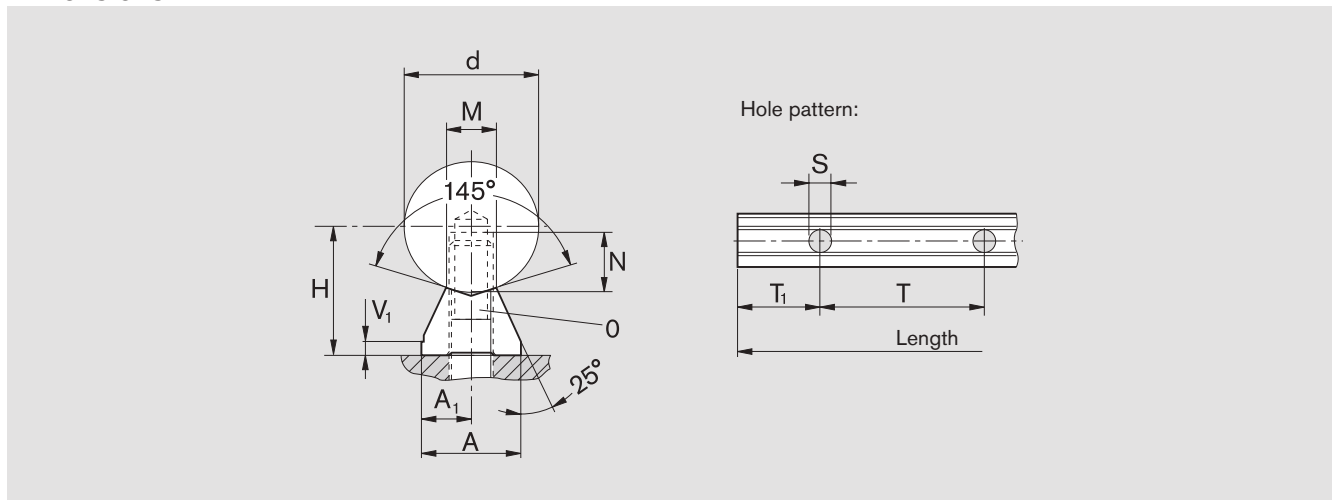

Dimensions (mm)									
$\varnothing d$	$H^{1)}$ ± 0.05	A	A_1	V_1	T	S	N	M	O
									ISO 4762-8.8
12	14.5	11	5.5	3	75	4.5	8	5.8	M4
16	18.0	14	7.0	3	75	5.5	9	7.0	M5
20	22.0	17	8.5	3	75	6.6	11	8.3	M6
25	26.0	21	10.5	3	75	9.0	15	10.8	M8
30	30.0	23	11.5	3	100	11.0	17	11.0	M10

1) Measured with gauging shaft, nominal dimension d and length about 50 mm. Up to 1,800 mm length with parallelism of 50 μm available upon request.



Steel shafts with ready-mounted shaft support rails for open standard and super linear bushings

Flangeless, with reference edge

R1016 steel shaft with ready-mounted shaft support rail

Material

- Shaft support rail: Steel

Design

- This steel support rail helps create highly compact guides and is designed for when installing the steel shaft from underneath. Compared to conventional flanged versions (see figure), this element has extremely low height.
- Reference edge makes aligning easier

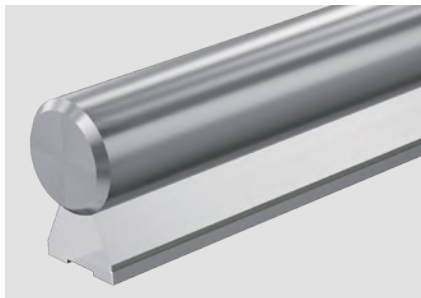
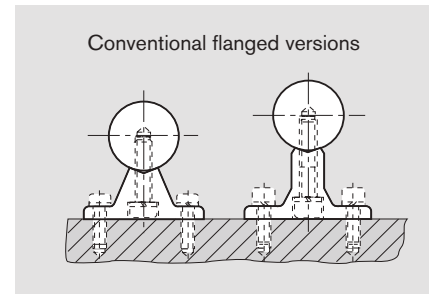
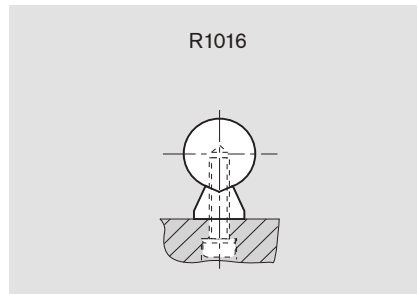

Shaft Ø d (mm)	Material number	Weight (kg/m)
16	R1016 016 ..	2.5
20	R1016 020 ..	3.8
25	R1016 025 ..	5.6
30	R1016 030 ..	7.6
40	R1016 040 ..	13.4
50	R1016 050 ..	20.2

Shafts:

- 00 = h6 heat-treated steel
- 01 = h7 heat-treated steel
- 30 = h6 stainless steel
- 31 = h7 stainless steel
- 60 = h6 hard chrome-plated heat-treated steel
- 61 = h7 hard chrome-plated heat-treated steel

Ordering example:

Shaft diameter 30 mm, h7, heat-treated steel, 900 mm long, ready-mounted shaft support rail:

R1016 030 01/900 mm.

Dimensions

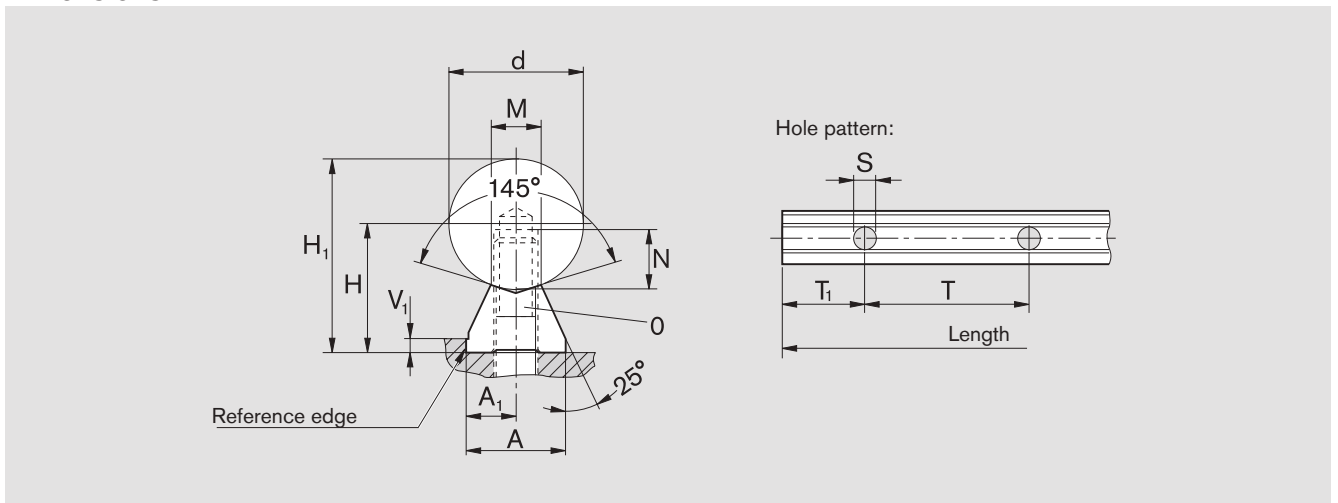

Dimensions (mm)											Grading tolerances (μm)			
$\varnothing d$	$H^{1)}$	H_1	A ± 0.02	A_1 ± 0.02	V_1	T	S	N	M	O DIN 4762-8.8	$H^{2)}$	h6 shaft $H_1^{3)}$	h7 shaft $H_1^{3)}$	$H_1^{3)}$
16	18	26.0	14	7.0	3	75	5.5	9	7.0	M5	20	32	36	
20	22	32.0	17	8.5	3	75	6.6	11	8.3	M6	20	33	38	
25	26	38.5	21	10.5	3	75	9.0	15	10.8	M8	20	33	38	
30	30	45.0	23	11.5	3	100	11.0	17	11.0	M10	20	33	38	
40	39	59.0	30	15.0	4	100	13.5	21	15.0	M12	20	35	41	
50	46	71.0	35	17.5	5	100	15.5	25	19.0	M14	20	35	41	

- 1) Tolerance: ± 0.02 mm; comes with a height grade of 20 μm .
- 2) Measured with gauging shaft, nominal dimension d and length about 50 mm. Up to 1,800 mm length with parallelism of 10 μm available upon request.
- 3) Includes shaft tolerance (determined from statistics).



Shaft support blocks

Product overview

The benefits

- For easy installing and quick aligning
- Precise design with reference edge
- More affordable than in-house designs

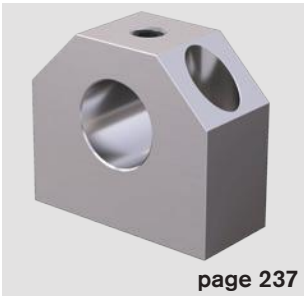

Aluminum compact R1058



Aluminum R1057



Cast iron, steel R1055



Cast iron flange R1056

Sample shaft support block:

Shaft support block
WBA-30-C-FO

Definition of codes		WB	A	30	C	FO	
Type	Shaft support block = WB						Fastening
Material	Cast iron = G						
	Aluminum = A						
	Steel = S						
Shaft diameter	= 30						Form

FO = Top securing	Fastening
P = For profile systems	
F = Flanged	
C = Compact	

Shaft support blocks

Compact shaft block, R1058

Material

- Aluminum

Design

- Very low height fitting linear sets with compact linear bushings
- Topside clamping for better accessibility
- Better security thanks to clamping screw with larger thread diameter
- Thread for fastening from below
- Drill hole for fastening from above



Shaft Ø d (mm)	Material number WBA-...C-FO	Weight (kg)
12	R1058 012 00	0.045
16	R1058 016 00	0.065
20	R1058 020 00	0.110
25	R1058 025 00	0.170
30	R1058 030 00	0.220
40	R1058 040 00	0.470
50	R1058 050 00	0.820

Dimensions

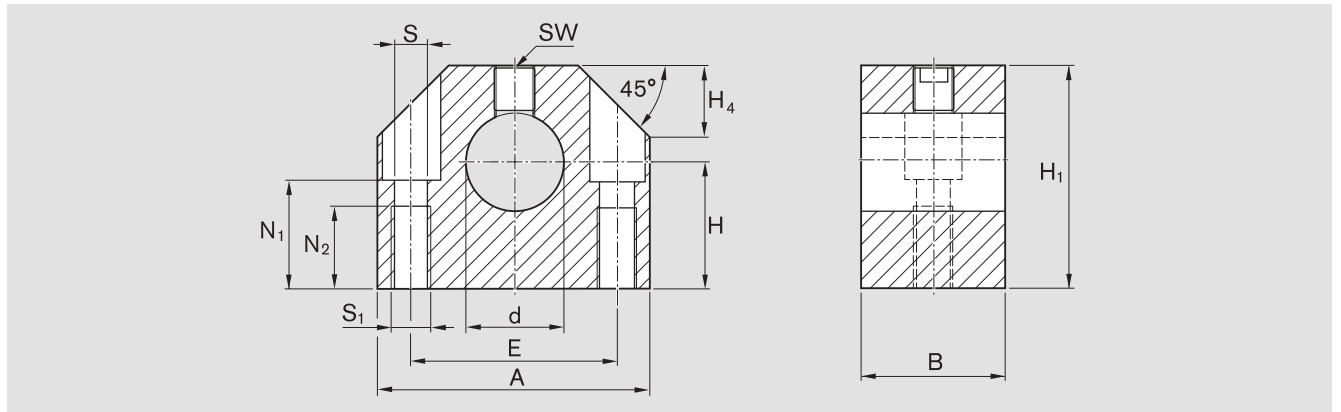

Dimensions (mm)													Tightening torque (Nm)
Ø d	d H8	H ¹⁾ ±0.01	H ₁	A	B	E ±0.15	S ²⁾	S ₁	N ₁	N ₂	H ₄	SW	
12	12	19	33	40	18	27	5.3	M6	16	13	11	2.5	3.8
16	16	22	38	45	20	32	5.3	M6	18	13	13	2.5	3.8
20	20	25	45	53	24	39	6.6	M8	22	18	15	3.0	6.6
25	25	31	54	62	28	44	8.4	M10	26	22	17	4.0	16.0
30	30	34	60	67	30	49	8.4	M10	29	22	19	4.0	16.0
40	40	42	76	87	40	66	10.5	M12	38	26	24	5.0	30.0
50	50	50	92	103	50	80	13.5	M16	46	34	30	6.0	52.0

1) In relation to nominal shaft dimension d

2) ISO 4762-8.8 fastening bolts

Explanation of sample short product name

WB	A	20	-	C	-	FO
Shaft support block	Aluminum	Ø 20		Compact series		Top securing

See page 236 for more information on short product names.

Note: Same version with side clamping available under R1058 7 ..



Shaft support blocks

Shaft support blocks, R1057

Material

- Aluminum

Design

- Rigid shaft mounting due to extra-wide design
- Topside clamping for better accessibility
- Better security thanks to clamping screw with larger thread diameter
- Thread for fastening from below
- Drill hole for fastening from above
- Reference edge for easy alignment



Shaft Ø d (mm)	Material number WBA-...-FO	Weight (kg)
10	R1057 010 00	0.05
12	R1057 012 00	0.06
16	R1057 016 00	0.11
20	R1057 020 00	0.18
25	R1057 025 00	0.35
30	R1057 030 00	0.48
40	R1057 040 00	0.90
50	R1057 050 00	1.50
60	R1057 060 00	3.00

Dimensions

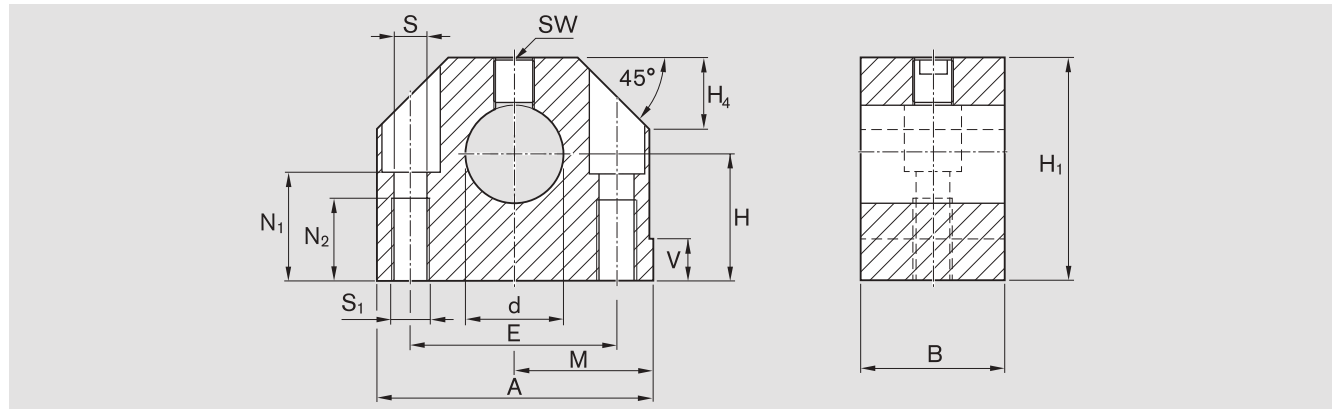

Dimensions (mm)																Tightening torque (Nm)
Ø d	d H8	H ¹⁾ ±0.01	H ₁	M ¹⁾ ±0.01	A	B	E	S ²⁾	S ₁	N ₁	N ₂	V	H ₄	SW		
10	10	18	31	20.0	40	20	27±0.15	5.3	M6	14.0	13	5.0	10	2.5	3.8	
12	12	20	35	21.5	43	20	30±0.15	5.3	M6	16.5	13	5.0	10	2.5	3.8	
16	16	25	42	26.5	53	24	38±0.15	6.6	M8	21.0	18	5.0	13	3.0	6.6	
20	20	30	51	30.0	60	30	42±0.15	8.4	M10	25.0	22	5.0	16	4.0	16.0	
25	25	35	61	39.0	78	38	56±0.15	10.5	M12	30.0	26	6.5	20	5.0	30.0	
30	30	40	70	43.5	87	40	64±0.15	10.5	M12	34.0	26	8.0	22	5.0	30.0	
40	40	50	88	54.0	108	48	82±0.15	13.5	M16	44.0	34	10.0	28	6.0	52.0	
50	50	60	105	66.0	132	58	100±0.20	17.5	M20	49.0	42	12.0	37	8.0	120.0	
60	60	75	130	82.0	164	74	124±0.20	22.0	M27	59.0	42	13.0	42	10.0	220.0	

1) In relation to nominal shaft dimension d 2) ISO 4762-8.8 fastening bolts

Explanation of sample short product name

WB	A	20	-	FO
Shaft support block	Aluminum	Ø 20		Top securing

See page 236 for more information on short product names.

Note: Same version with side clamping available under R1057 7 ..



Shaft support blocks

Shaft support blocks, R1055

Material

- Spheroidal graphite cast iron
- Steel

Design

- Side clamping

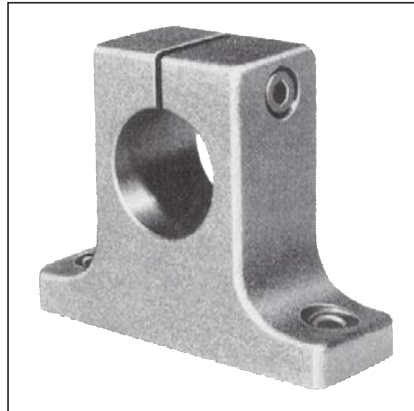

Shaft Ø d (mm)	Material number WBG-...	Weight (kg)
8	R1055 008 00	0.04
12	R1055 012 00	0.06
16	R1055 016 00	0.12
20	R1055 020 00	0.22
25	R1055 025 00	0.37
30	R1055 030 00	0.55
40	R1055 040 00	0.97
50	R1055 050 00	1.90
60	R1055 060 00	3.60
80	R1055 080 00	7.30

Dimensions

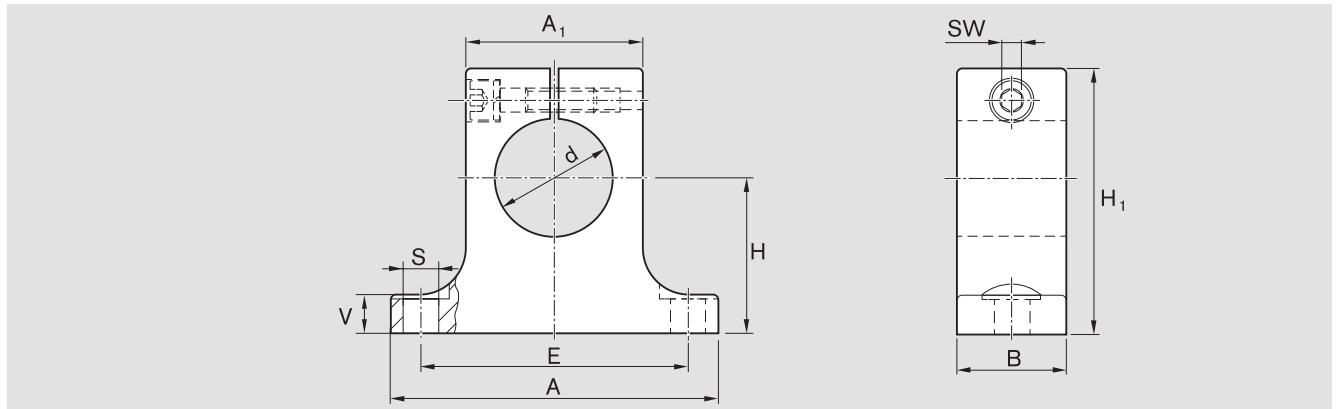

Dimensions (mm)											
Ø d	d H8	H ¹⁾	H ₁ ²⁾	A ²⁾	A ₁ ²⁾	B ²⁾	E	S ³⁾	V ²⁾	SW	
8	8	15±0.010	27	32	16	10	25±0.15	4.5	5.0	2.5	
12	12	20±0.010	35	42	20	12	32±0.15	5.5	5.5	3.0	
16	16	25±0.010	42	50	26	16	40±0.15	5.5	6.5	3.0	
20	20	30±0.010	50	60	32	20	45±0.15	5.5	8.0	3.0	
25	25	35±0.010	58	74	38	25	60±0.15	6.6	9.0	4.0	
30	30	40±0.010	68	84	45	28	68±0.20	9.0	10.0	5.0	
40	40	50±0.010	86	108	56	32	86±0.20	11.0	12.0	6.0	
50	50	60±0.015	100	130	80	40	108±0.20	11.0	14.0	6.0	
60	60	75±0.015	124	160	100	48	132±0.25	13.5	15.0	8.0	
80	80	100±0.015	160	200	130	60	170±0.50	17.5	22.0	10.0	

1) In relation to nominal shaft dimension d

2) ISO 8062-3 - DCTG 11 tolerance

3) ISO 4762-8.8 socket head cap bolts.

Explanation of sample short product name

WB	G	20
Shaft support block	Spheroidal graphite cast iron	Ø 20

See page 236 for more information on short product names.



Shaft support blocks

Shaft support block, R1056 Flanged

Material

- Lamellar graphite cast iron

Design

- Compared to installing the shafts in customer-made bores, flanged shaft support blocks allow the shafts to be aligned and prevent the linear bushings from overloading due to shafts that are not parallel
- Side clamping screw



Shaft Ø d (mm)	Material number WBG-...F	Weight (kg)
12	R1056 012 00	0.15
16	R1056 016 00	0.21
20	R1056 020 00	0.28
25	R1056 025 00	0.41
30	R1056 030 00	0.75
40	R1056 040 00	1.65
50	R1056 050 00	2.60

Dimensions

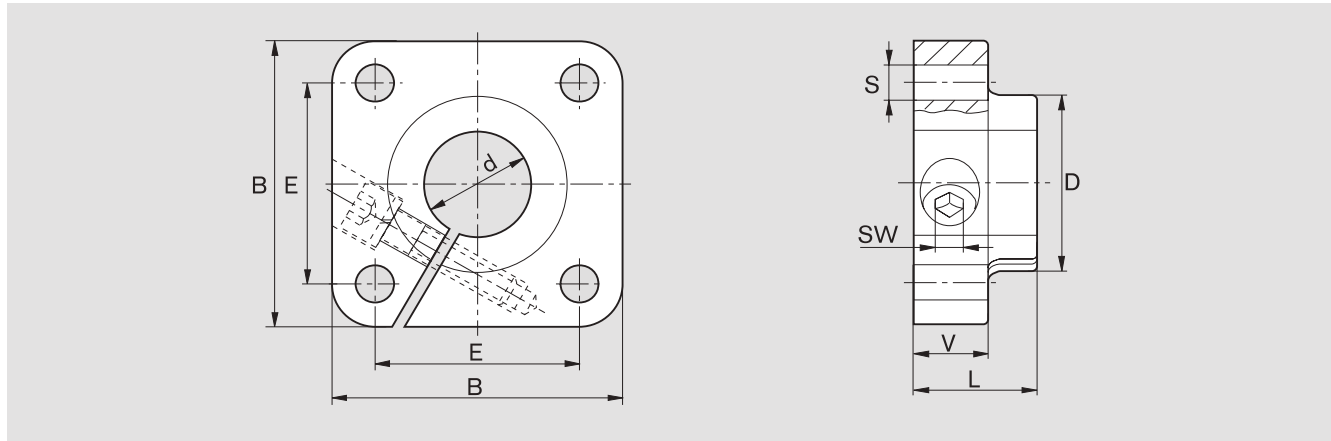

Dimensions (mm)									
Ø d	d H7	B ¹⁾	L ¹⁾	D ¹⁾	E	S H13	V ¹⁾	SW	
12	12	42	20	23.5	30±0.12	5.5	12	3	
16	16	50	20	27.5	35±0.12	5.5	12	3	
20	20	54	23	33.5	38±0.15	6.6	14	4	
25	25	60	25	42.0	42±0.15	6.6	16	5	
30	30	76	30	49.5	54±0.25	9.0	19	6	
40	40	96	40	65.0	68±0.25	11.0	26	8	
50	50	106	50	75.0	75±0.25	11.0	36	8	

1) ISO 8062-3 - DCTG 9 tolerance

Explanation of sample short product name

WB	G	20	-	F
Shaft support block	Lamellar graphite cast iron	Ø 20		Flanged

See page 236 for more information on short product names.

Further information

Here you will find extensive information on products, eShop, training and services.

Product information:

<http://www.boschrexroth.com/en/xc/products/product-groups/linear-motion-technology/index>

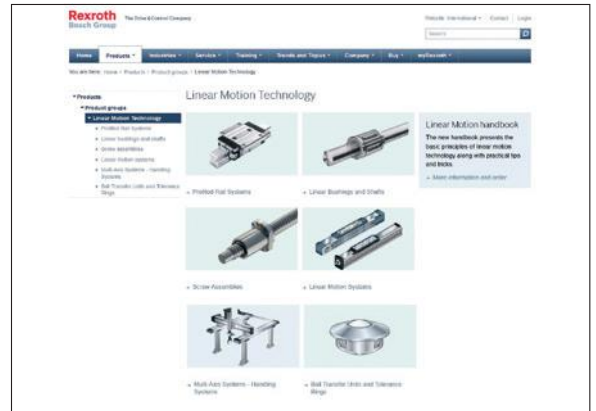

eShop:

<http://www.boschrexroth.com/eshop>

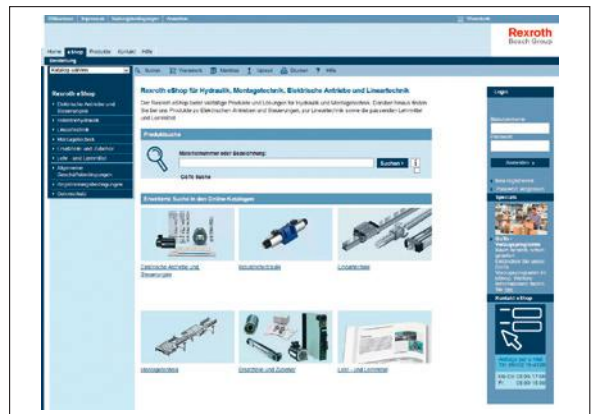

Training:

<http://www.boschrexroth.com/training>



Service:

<http://www.boschrexroth.com/service>



Notes

Bosch Rexroth AG

Ernst-Sachs-Straße 100
97424 Schweinfurt, Deutschland
Phone +49 9721 937-0
Fax +49 9721 937-275
www.boschrexroth.com

Find your local contact here:

www.boschrexroth.com/contact